

**POWERLINE CARRIER
ISOLATION TRANSFORMERS****P2820
P2821
P2822
P2823****Features**

- * Lead-free (Pb-free)
- * RoHS compliant
- * Reinforced insulation
- * 14.6mm seated height
- * Vacuum encapsulated
- * Low distortion
- * IEC 60950 and UL 60950 certified
- * UL Recognized Component

Applications

- * Powerline Carrier

DESCRIPTION

The family of transformers P2820, P2821, P2822 and P2823 is specifically designed to provide signal coupling with safety for Powerline Carrier applications over four bands from 40kHz to 148.5kHz.

Typically, the devices are driven from low-impedance sources and are connected to the mains network using capacitors whose values are chosen to resonate with the transformer leakage inductance.

They are particularly suitable for use with tri-state power amplifiers, e.g. Texas Instruments TLE2301.

The devices are completely lead-free, compliant with RoHS Directive 2002/95/EC, and suitable for lead-free and conventional processing.

The devices are certified to IEC 60950 and UL 60950 for reinforced insulation. They are UL Recognized Components and are supported by an IEC CB Test Certificate. Furthermore, the devices are designed for low distortion and meet the requirements of EN 50065-1 for conducted emissions.

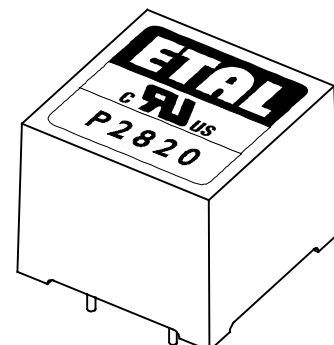

SPECIFICATIONS

Distortion

Exceed requirements of EN 50065-1 (1991) for conducted emissions

Conditions:

P2820, Fundamental 40-90kHz into artificial mains network of EN 50065-1 at 122dB μ V and AC magnetizing current of 40mA rms at 50Hz. Circuit as Figure 1.

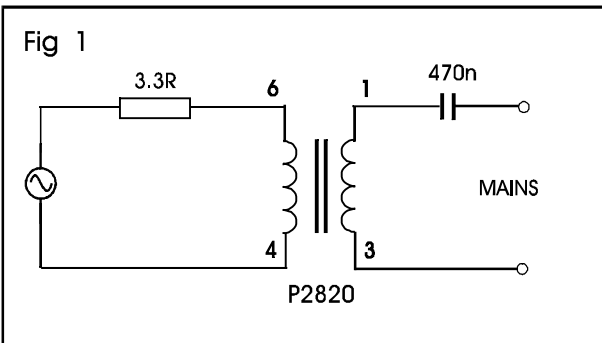

P2822, Fundamental 125-140kHz into artificial mains network of EN 50065-1 at 116dB μ V and AC magnetizing current of 3mA rms at 50Hz. Circuit as Figure 3.

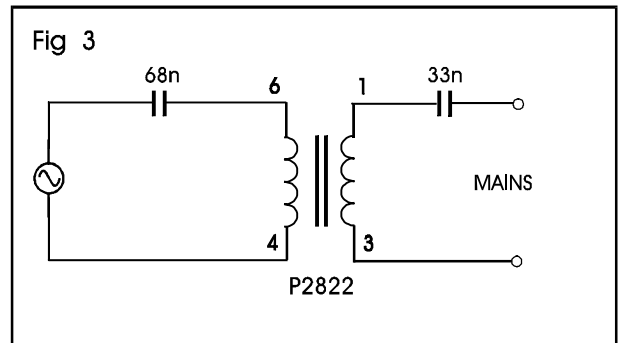

P2821, Fundamental 95-125kHz into artificial mains network of EN 50065-1 at 116dB μ V and AC magnetizing current of 10mA rms at 50Hz. Circuit as Figure 2.

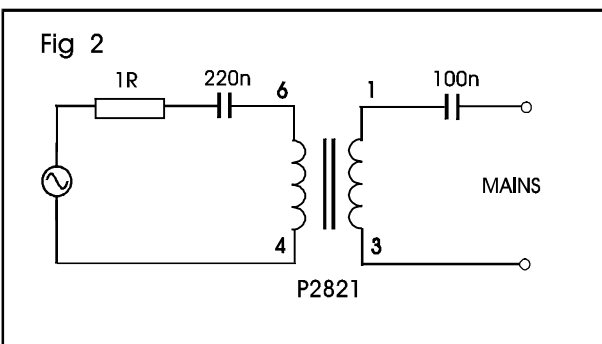

P2823, Fundamental 140-148.5kHz into artificial mains network of EN 50065-1 at 116dB μ V and AC magnetizing current of 3mA rms at 50Hz. Circuit as Figure 4.

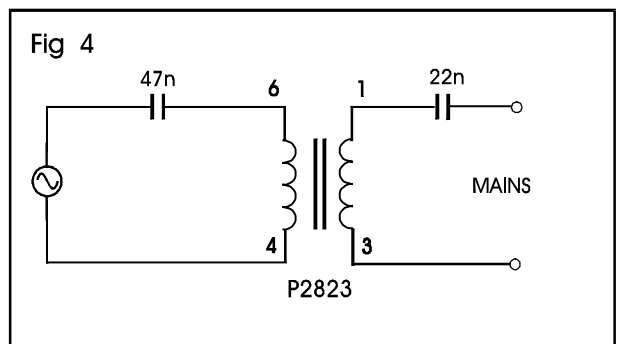

Summary Specification

Voltage Isolation

4kVrms at 50Hz

Operating range

Ambient	-25 to +85°C
Storage	-40 to +125°C
Relative Humidity	to 95%

Typical lumped parameters as Fig. 5 referred to pins 1-3.

Parameter	Conditions	P2820	P2821	P2822	P2823	Units
Series resistance R_s (DCR+ AC resistance)	1V 100kHz	0.5	0.6	1.0	1.3	Ω
Leakage inductance ΔL	1V 100kHz	14.4	22	46	58	μH
Shunt inductance L_p	1V 100kHz	400	600	1200	1600	μH
Shunt loss R_p	1V 100kHz	>20	>20	>20	>20	k Ω
Turns ratio, N	1V 100kHz	1.67	3.22	3.15	3.00	

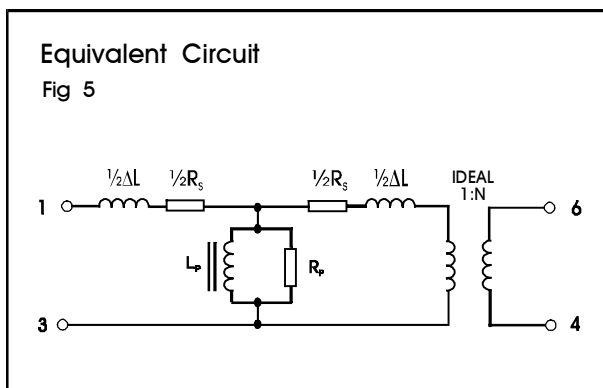

Detailed Specification, P2820

Electrical

At T = 25°C and as circuit fig. 5 unless otherwise indicated.

Parameter	Conditions	Min	Typ	Max	Units
Series resistance	Referred to pins 1-3				
	40kHz	0.2	0.27	-	Ω
	90kHz	-	0.38	0.7	Ω
	40-90kHz	0.2	-	0.7	Ω
Saturation Current	1-3; 5% drop in shunt inductance, L_p	120	150	-	mA
Thermal resistance	Coil to ambient	-	50	70	$^{\circ}\text{C}/\text{W}$
Turns ratio, N		1.65	1.68	1.71	-
Voltage isolation ⁽¹⁾	50Hz	4.0	-	-	kVrms
	DC	5.5	-	-	kV
Operating range:	Ambient temperature				
		Functional	-25	-	+85
Storage		-40	-	+125	$^{\circ}\text{C}$

Lumped equivalent circuit parameters as Fig. 6

DC resistance	1-3, -25°C to +85°C	0.08	-	0.2	Ω
	4-6, -25°C to +85°C	0.20	-	0.54	Ω
Leakage inductance ΔL	-25°C to +85°C	13.9	14.9	15.9	μH
Shunt inductance L_p	25°C	300	500	700	μH
	-25°C to +85°C	175	-	1200	μH
Shunt loss R_p		10	-	-	k Ω
Interwinding capacitance, C_{iw}	1,3 : 4,6	-	8	20	pF

Notes:

- Components are 100% tested at 6.5kVDC.

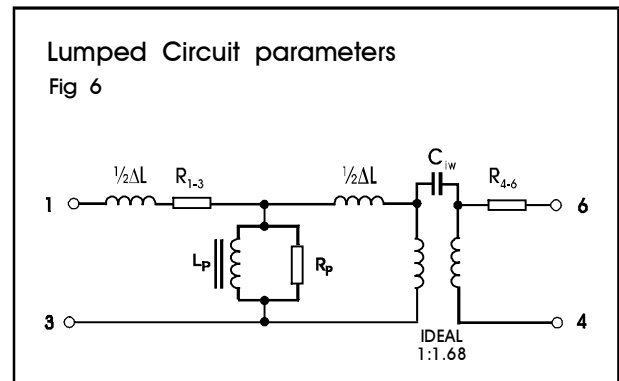

CONSTRUCTION

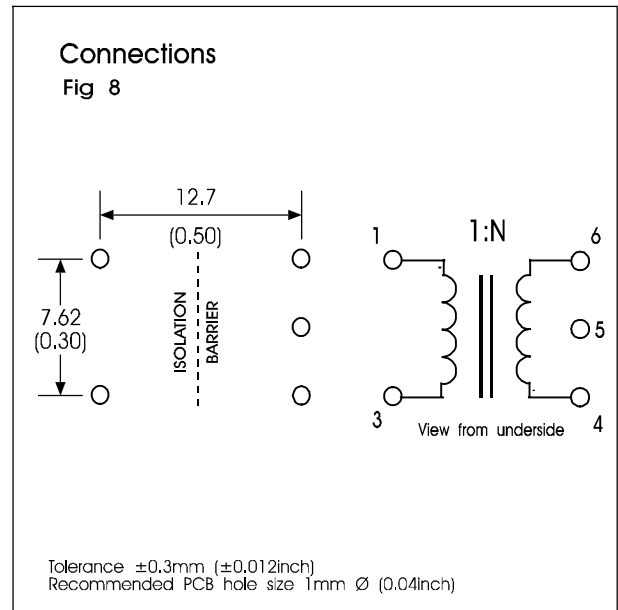
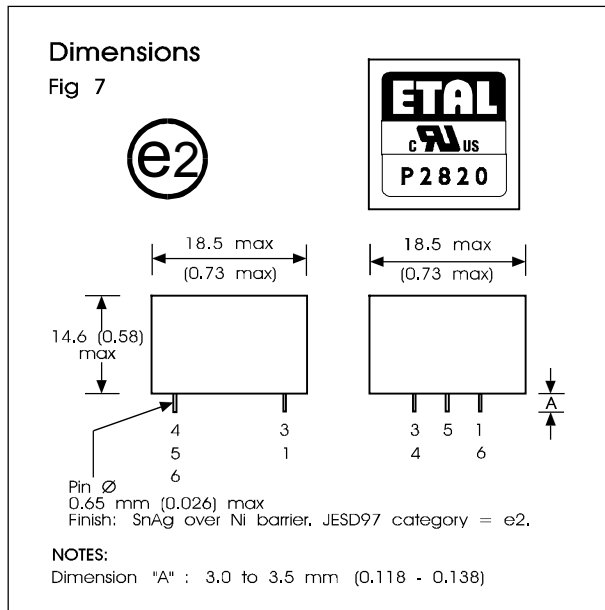

Dimensions shown are in millimetres (inches).

Geometric centres of outline and pad grid coincide within a tolerance circle of 0.3mm \varnothing .

Windings may be used interchangeably a primary or secondary.

SAFETY

Constructed in accordance with IEC 60950-1:2001, EN 60950-1:2001 and UL 60950-1, first Edition, reinforced insulation 250Vrms maximum working voltage, flammability class V-0.

Distance through solid insulation 0.4mm minimum.

Creepage and clearances in circuit are 9mm minimum where PCB pads do not exceed $\varnothing 3\text{mm}$.

CERTIFICATION

Certified under the IEC CB scheme (Certificate DK-9431) to IEC 60950-1:2001, sub-clauses 1.5, 1.5.1, 1.5.2, 1.7, 1.7.1, 2, 2.9, 2.9.1, 2.9.2, 2.9.3, 2.10, 2.10.1, 2.10.2, 2.10.3, 2.10.3.1, 2.10.3.3, 2.10.4, 2.10.5, 2.10.5.1, 2.10.5.4, 4, 4.7, 4.7.1, 4.7.3, 4.7.3.1, 4.7.3.4, 5, 5.2, 5.2.1, and 5.2.2 for a maximum working voltage of 250Vrms, nominal mains supply voltage not exceeding 250Vrms and a maximum operating temperature of 85°C in Pollution Degree 2 environments, reinforced insulation, including national differences for Denmark, Finland, Germany, Norway, Sweden, Switzerland, USA, Canada and UK.

Recognized under the Component Recognition Program of Underwriters Laboratories Inc. to US and Canadian requirements CAN/CSA C22.2 No. 60950-1-03/UL60950-1, First Edition, based on IEC 60950-1, First Edition, maximum working voltage 250Vrms, Pollution Degree 2, reinforced insulation.

UL File number E203175.

Additionally, Profec Technologies certifies all transformers as providing voltage isolation of 3.88kVrms, 5.5kV DC minimum. All shipments are supported by a certificate of conformity to current applicable safety standards.



P2820, P2821, P2822, P2823

ABSOLUTE MAXIMUM RATINGS

(Ratings of components independent of circuit).

Short term isolation voltage (1s)	4.6kVrms, 6.5kVDC
Coil temperature (continuous)	155°C
Storage temperature	-40°C to +125°C
Lead temperature, 10s	260°C

COPYRIGHT

ETAL, P2820, P2821, P2822, and P2823 are Trade Marks of Profec Technologies Ltd. The Trade Mark ETAL is registered at the UK Trade Marks Registry. Profec Technologies Ltd. is the owner of the design right under the Copyright Designs and Patents Act 1988 and no rights or licences are hereby granted or implied to any third party.

© 1996 - 2006 Profec Technologies Ltd.
Reproduction prohibited.



ISO 9001
FM 25326

Profec Technologies Ltd., 10 Betts Avenue, Martlesham Heath, Ipswich, IP5 3RH, England

Telephone: +44 (0) 1473 611422

Website: www.profec.com

Fax: +44 (0) 1473 611919

Email: info@profec.co.uk sales@profec.com