

# MICROPROFILE PICK-OFF TRANSFORMER

# P3190

## Features

- \* Surface Mount
- \* Lead-free (Pb-free)
- \* RoHS compliant
- \* 7mm seated height
- \* Vacuum encapsulated
- \* IEC 60950 and UL 60950 Certified
- \* UL Recognized Component

## Applications

- \* Telecommunications
- \* Pick-off applications
- \* Voice recording
- \* Instrumentation

## DESCRIPTION

P3190 is a high impedance microprofile transformer for applications where safety isolation to international standards is required in an extremely small case size.

Designed specifically as a surface mount device, P3190 features a 7mm seated height. The part is compliant with RoHS Directive 2002/95/EC, and suitable for lead-free and conventional placement and reflow.

P3190 is designed for "listening" applications when placed across a line, presenting a high impedance exceeding 10k $\Omega$  across the voiceband to minimize circuit loading.

For applications requiring higher impedance, P2769 offers >30k $\Omega$  in a compatible package.

To meet requirements for  $\geq 40\text{k}\Omega$  across the voiceband, P3190 can be used in an application circuit described herein.

P3190 is certified to IEC 60950 and UL 60950. P3190 is a UL Recognized Component and is supported by an IEC CB Test Certificate.

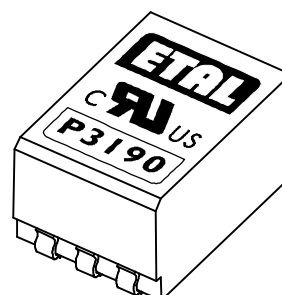

## SPECIFICATIONS

### Electrical

At T = 25 °C unless otherwise stated.

Parameter	Conditions	Min	Typ	Max	Units
Voltage isolation <sup>(1)</sup>	50Hz	3.88	-	-	kVrms
	DC	5.5	-	-	kV
Input impedance <sup>(4)</sup>	300Hz - 3.4kHz, 1Vrms, circuit as Fig.2.	10	-	-	kΩ
Operating range: Functional Storage <sup>(3)</sup> Humidity	Ambient temperature	-25	-	+85	°C
		-40	-	+125	°C
		-	-	95	%R.H.
		-	-	-	-

Lumped equivalent circuit parameters as Fig. 1

DC resistance, $R_{DC}$ <sup>(2)</sup>	Sum of windings	882	-	1055	Ω
Leakage inductance $\Delta L$		18	-	22	mH
Shunt inductance $L_p$	200Hz 10mV	6.5	-	16	H
Shunt loss $R_p$	200Hz 10mV	22	-	66	kΩ

### Notes

- Components are 100% tested at 6.5 kVDC.
- Caution: do not pass DC through windings. Telephone line current, etc. must be diverted using choke or semiconductor line hold circuit.
- Excludes shipping materials. Components are dry-packed and sealed as shipped. Handle in accordance with IPC/JEDEC J-STD-033 procedure for components classified as IPC/JEDEC J-STD-020 Moisture Sensitivity Level 5a.
- For applications requiring higher input impedance (e.g.  $\geq 40k\Omega$ ), see application circuits below.

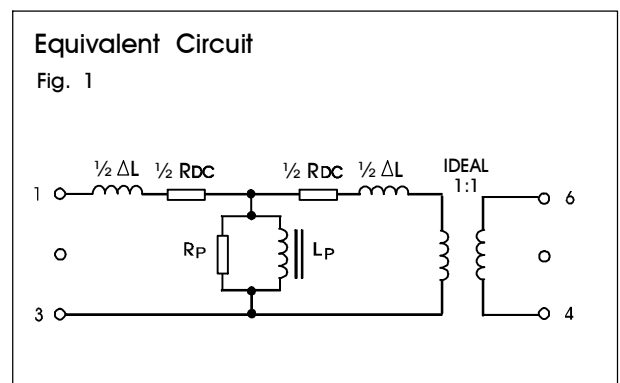

## Reference Circuit

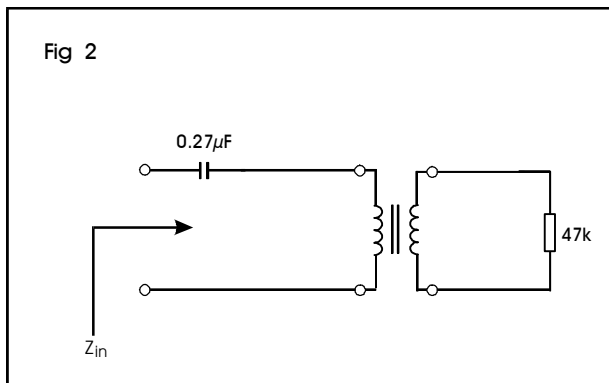

In practice, the  $47\text{k}\Omega$  load can be increased without limit. The DC blocking capacitor should be maintained within the range  $0.22\mu\text{F}$  to  $0.33\mu\text{F}$  to obtain a flat frequency response and input impedance to specification.

## 40kΩ APPLICATION CIRCUITS

For applications requiring impedance greater than  $40\text{k}\Omega$  for parallel-connected Terminal Equipment (e.g. ETSI TS 103 021,  $\geq 40\text{k}\Omega$ ,  $200\text{Hz} - 4.3\text{kHz}$ ) the following circuits may be helpful.

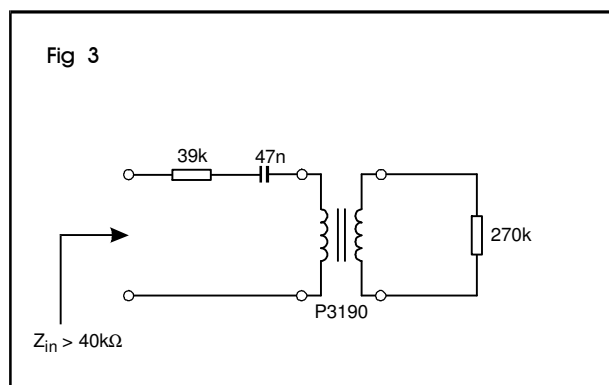

At the expense of a small loss, the circuit in Fig. 3 provides an impedance exceeding  $40\text{k}\Omega$  from DC upwards.

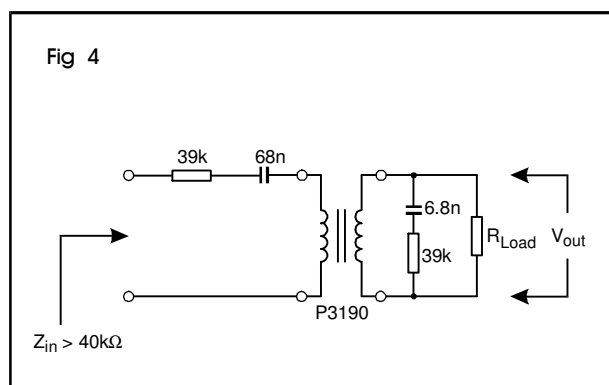

Due to the finite primary inductance of the P3190, the circuit of Fig. 3 suffers from low frequency rolloff below  $500\text{Hz}$ . At the expense of around  $6\text{dBV}$  loss, the circuit of Fig. 4 provides a relatively flat response from  $300\text{Hz}$  to  $4\text{kHz}$ .

The load resistance,  $R_{Load}$ , across which the output voltage appears, should be a minimum of  $470\text{k}\Omega$ , and can be increased without limit.

## CONSTRUCTION

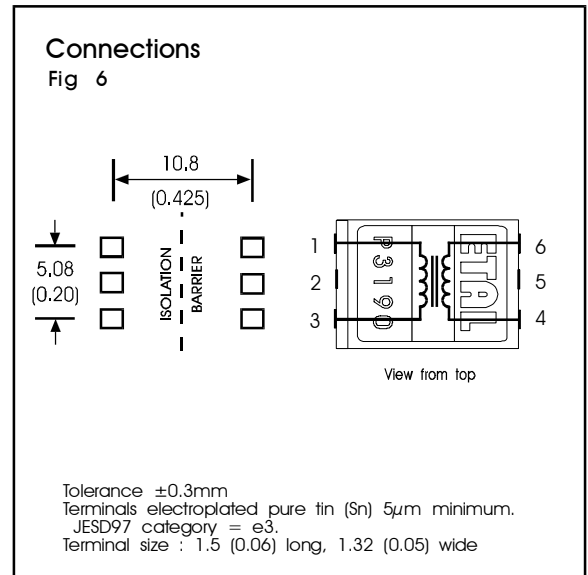
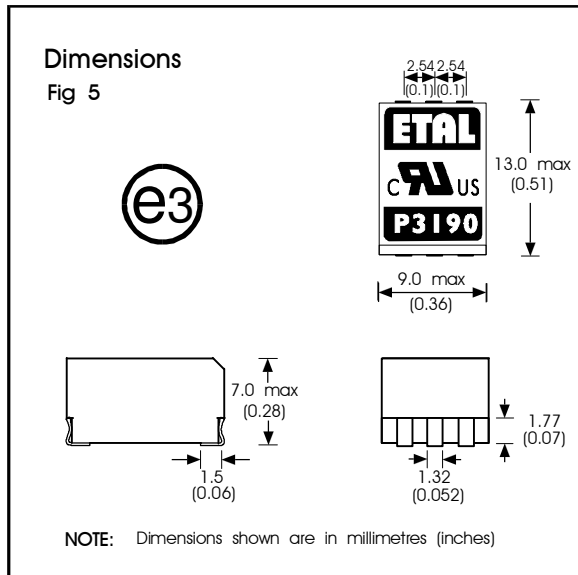

Dimensions shown are in millimetres (inches).

Geometric centres of outline and pad grid coincide within a tolerance circle of  $0.3\text{mm}\varnothing$ .

Windings may be used interchangeably as primary or secondary.

## SAFETY

Manufactured from materials conforming to flammability requirements of UL94V-0.

Distance through reinforced insulation 0.4mm minimum.

Creepage and clearances in circuit are 7mm minimum where PCB pads do not exceed  $3\text{mm}\varnothing$ .

Construction complies with IEC 60950-1, EN 60950-1 and UL 60950-1, reinforced insulation, 250Vrms maximum working voltage

## ABSOLUTE MAXIMUM RATINGS

(Ratings of components independent of circuit).

Short term isolation voltage (2s) 4.6 kVrms,  
6.5kVDC

DC current 100 $\mu\text{A}$

Storage temperature -40 $^{\circ}\text{C}$  to  
+125 $^{\circ}\text{C}$

Soldering temperature

Profile peak 260 $^{\circ}\text{C}$  10s

Recommended peak body temperature 245 $^{\circ}\text{C}$  in  
accordance with IPC/JEDEC J-STD-033.

## CERTIFICATION

Certified by BSI to IEC 60950 Third Edition (1999) (IEC CB Test Certificate No. GB592W) sub-clauses 1.5, 1.5.1, 1.5.2, 2.9, 2.9.1, 2.9.2, 2.9.3, 2.9.4, 2.9.5, 2.10, 2.10.1, 2.10.2, 2.10.3, 2.10.3.1, 2.10.3.2, 2.10.4, 2.10.5, 2.10.5.1, 2.10.7, 2.10.8, 4.7, 4.7.3, 4.7.3.1, 4.7.3.4, (Flammability Class V-0) 5.2, 5.2.1, and 5.2.2 for a maximum working voltage of 250Vrms, nominal mains supply voltage not exceeding 250Vrms and a maximum operating temperature of +85 $^{\circ}\text{C}$  in Pollution Degree 2 environment, reinforced insulation.

Recognized under the Component Recognition Program of Underwriters Laboratories Inc. to US and Canadian requirements CAN/CSA C22.2 No. 60950-1-03/UL60950-1, First Edition, based on IEC 60950-1, First Edition, maximum working voltage 250Vrms, Pollution Degree 2, reinforced insulation.

UL File number E203175.

Additionally, Profec Technologies certifies all transformers as providing voltage isolation of 3.88kVrms, 5.5kV DC minimum. All shipments are supported by a Certificate of Conformity to current applicable safety standards.

## ORDERING CODE

P3190□□



TR = Tape and Reel  
(Blank) = Bulk in tubes.

Carrier tape width 24mm,  
500 parts per 13" reel.

## COPYRIGHT

ETAL, P3190 and P2769 are Trade Marks of Profec Technologies Ltd.

The Trade Mark ETAL is registered at the UK Trade Marks Registry.

Profec Technologies Ltd. is the owner of the design right under the Copyright Designs and Patents Act 1988 and no rights or licences are hereby granted or implied to any third party.

British Patent No. 2283195

US Patent No. 5879598

European Patent No. 0725719

© 1999 - 2007 Profec Technologies Ltd.  
Reproduction prohibited.



ISO 9001  
FM 25326

Profec Technologies Ltd., 10 Betts Avenue, Martlesham Heath, Ipswich, IP5 3RH, England

Telephone: +44 (0) 1473 611422

Fax: +44 (0) 1473 611919

Website: [www.profec.com](http://www.profec.com)

Email: [info@profec.co.uk](mailto:info@profec.co.uk) [sales@profec.com](mailto:sales@profec.com)