



ROHM LED Driver

Overview

ROHM LED Driver: History

Wide application range from consumers to automotive

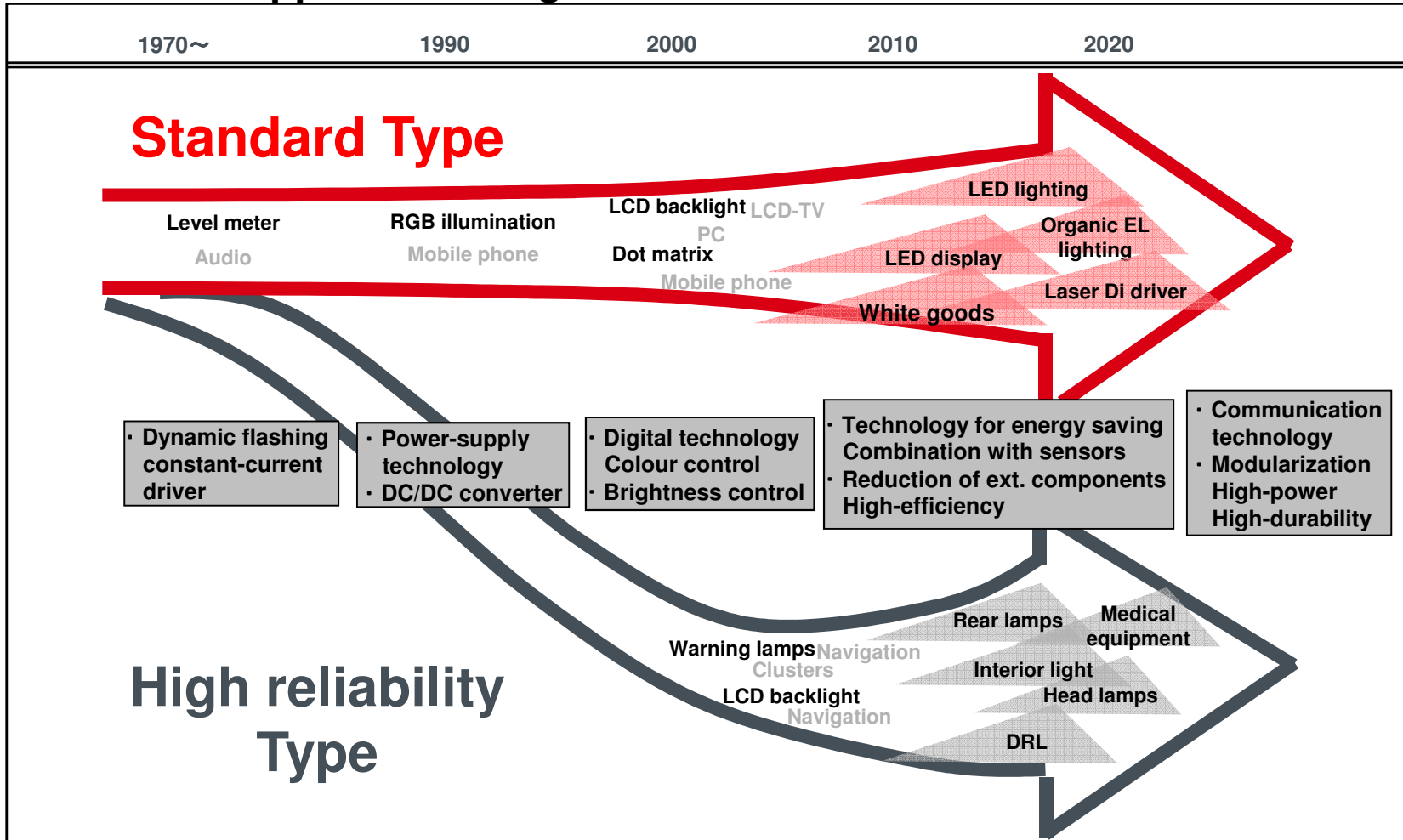

LED Drivers – Standard LineUp

LED Drivers – Standard LineUp

- **Serial/parallel Constant Current Driver**
- **Driver for LCD back lighting**
- **Driver for Illumination & Decoration & Matrix Displays**
- **Driver for Indicators**
- **Driver for Flash/Torch Lighting**
- **General Lighting LED Driver**

Simple Constant Current Driver without step-up converter

Features

- Low Dropout Constant current driver
- Current DAC integrated
- Small package
- Li-ion battery corresponded

Line-up

Part No.	LED number	Current DAC	I/F	Size [mm]
BD1754HFN	Max 4	64steps	UPIC *3	2.9 x 2.8 HSON8
BDxxx2	2	32steps(Log)	UPIC+	2.9 x 2.8 SSOP5 (TBD)
BDxxx3	3	32steps(Log)	UPIC+	2.9 x 2.8 SSOP6 (TBD)
BDxxx4	4	32steps(Log)	UPIC+	VSON008X2020 (TBD)
BDxxx5	5	32steps(Log)	UPIC+	VSON008X2020 (TBD)
BDxxx6	6	32steps(Log)	UPIC+	VSON010X3020 (TBD)

*3 : UPIC+ is Uni-Port Interface Control + like as 1-wire interface

- Mass production
- New product
- Under development

Block Diagram

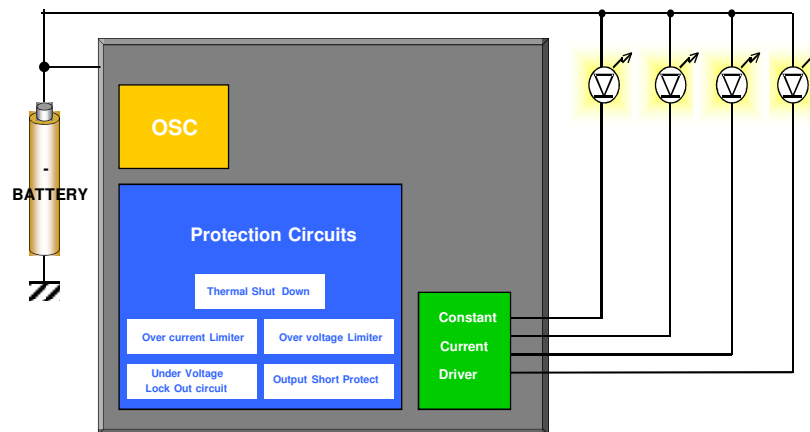

Parallel connection type with charge pump

Features

- High Efficiency Charge pump (x1/x1.5/x2)
- Current DAC integrated
- Small package
- Li-ion battery corresponded
- External PWM brightness control

Line-up

Part No.	LED number	Current DAC	PWM Control	I/F	Size [mm]
BD1604MUV	Max 4	-	○	Pin	3.0 x 3.0 QFN
BD1604MVV	Max 4	-	○	Pin	4.0 x 4.0 QFN
BD1601MUV	Max 4	64steps	-	UPIC *2	3.0 x 3.0 QFN
BD1606MVV	Max 6	64steps	-	I2C	4.0 x 4.0 QFN
BD1603NUV	Vo fixed	-	○	Pin	3.0 x 3.0 SON
BD82103GWL	Max 3	16steps(Log)	-	UPIC+ *2	1.8 x 1.5 CSP
BD1204GWL	Max 4	16steps(Log)	CPWM *1	UPIC+ *2	1.85 x 1.85 CSP
BD1206GUL	Max 6	16steps(Log)	CPWM *1	UPIC+ *2	2.0 x 2.0 CSP
BU90030G	Vo fixed	-	○	Pin	SSOP6

*1 : CPWM is Current PWM solution that brings low noise in PWM brightness control

*3 : UPIC, UPIC+ are Uni-Port Interface Control like as 1-wire interface

Block Diagram

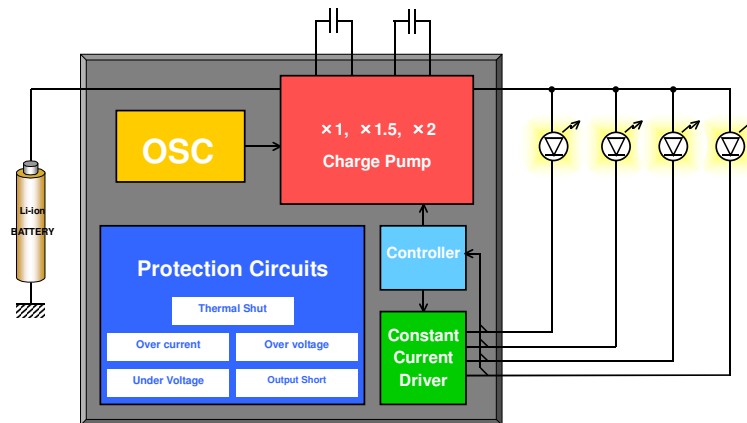

- Mass production
- New product
- Under development

Serial connection type

Features

- High Efficiency synchronous DC/DC
- Load disconnect switch integrated [BD6xxxGUT]
- Auto Luminous Control integrated [BD60910GU]
- Small package
- Li-ion battery corresponded

Block Diagram

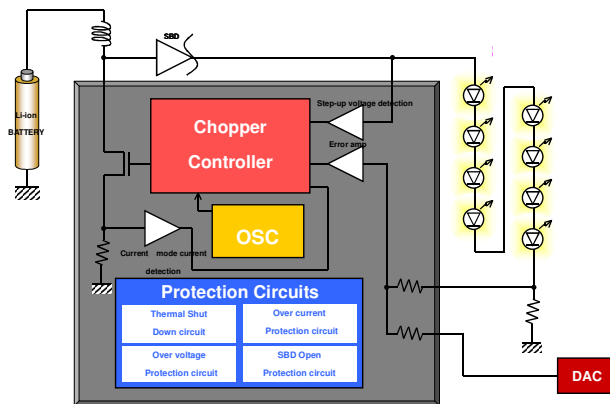

Line-up

Part No.	LED number	Synch.	Brightness Control	Other Function	Size [mm]
BD6067GU	Max 8	-	PWM or DC	-	1.68 x 1.68 CSP
BD6071HFN	Max 3	○	PWM or DC	-	3.0 x 2.9 HSON8
BD6072HFN	Max 4	○	PWM or DC	-	3.0 x 2.9 HSON8
BD6069GUT	Max 4	○	PWM or DC	-	1.68 x 1.68 CSP
BD6077GUT	Max 4	○	PWM or DC	-	1.68 x 1.68 CSP
BD6074GUT	Max 3	○	PWM or DC	-	1.68 x 1.68 CSP
BD6076GUT	Max 4	○	PWM or DC	Load Disconnect	1.68 x 1.68 CSP
BD6091GU	Max 8	-	DAC + PWM	ALC	3.0 x 3.0 CSP
BD60910GU	Max 8	-	DAC + PWM	ALC (Log sensor)	3.0 x 3.0 CSP
BD60A00NUX	Max 10	-	PWM over 20kHz	-	VSON008X2030
BD60A60NUX	Max 6	-	PWM over 20kHz	-	VSON008X2030
BD60H60MWX	Max 6	-	PWM to DC	GPO 5Ch	VSON016V3315
BDxxxMUX	Max 4	(○)	PWM	-	VSON008X2020 (TBD)
BDxxxMUX	Max 6	(○)	PWM	-	VSON008X2020 (TBD)

ALC : Auto Luminous Control. It realize low power system.

- Mass production
- New product
- Under development

Multi-function parallel type

Features

- High Efficiency Charge pump
- High Efficiency Serial DC/DC
- RGB illumination Driver
- LDO integrated
- Low power ALC function
- Low noise PWM control
- Flash LED driver
- GPIO
- Small CSP package
- Li-ion battery corresponded

Block Diagram

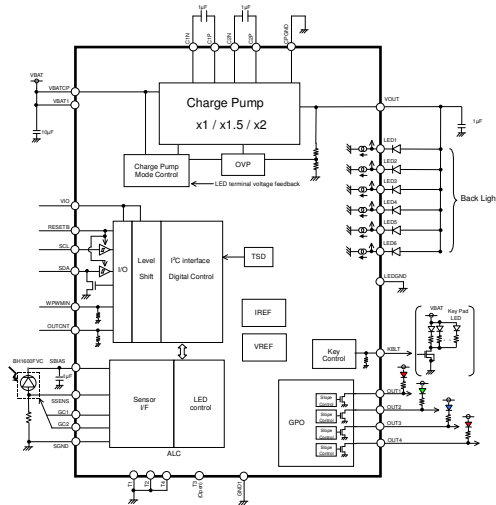

Line-up

Part No.	Back Lighting	DC/DC	RGB	LDO	ALC	PWM	Other	Package
BD6081GU	Max 6	Charge Pump	6LED	2Ch	-	-	-	3.9 x 3.9 CSP
BD6085GUL	Max 7	Charge Pump	-	4Ch	-	-	Flash	3.3 x 3.3 CSP
BD6086GU	Max 7	Charge Pump	6LED	2Ch	○	○	GPIO 4Ch	4.5 x 4.5 CSP
BD60xxGU	Max 7	Charge Pump	3LED	2Ch	○	○	GPIO 4Ch	4.5 x 4.5 CSP
BD6095GUL	Max 5	Charge Pump	-	4Ch	○	○	Flash	3.75 x 3.75 CSP
BD6088GUL	Max 6	Charge Pump	4LED	-	○	○	(GPO)	3.5 x 3.5 CSP
BD6098GUL	Max 6	Charge Pump	4LED	-	○	○	(GPO)	3.5 x 3.5 CSP
BD6091GU	Max 8	DC/DC	-	-	○	○	-	3.0 x 3.0 CSP
BD6092GU	-	-	-	-	○	○	PWM Out	2.8 x 2.8 CSP
BD6107GU	Max 12 (3 x 4)	DC/DC	6LED	3Ch	-	○	GPIO 4Ch GPO 8Ch	4.3 x 4.3 CSP
BD60910GU	Max 8	DC/DC	-	-	○(Log)	○	-	3.0 x 3.0 CSP
BD6083GUL	Max 6	Charge Pump	-	4Ch	○	○	-	3.15 x 3.15 CSP
BD6084GUL	Max 8	Charge Pump	-	4Ch	○	○	-	3.15 x 3.45 CSP
BD6183GUL	Max 6	Charge Pump	-	4Ch	-	○	-	3.15 x 2.65 CSP
BD6184GUL	Max 8	Charge Pump	-	4Ch	-	○	-	3.15 x 3.10 CSP
BD6082GUL	Max 7	Charge Pump	3LED	-	-	○	AUX 6Ch	3.60 x 3.60 CSP
BU61800GWL	Max 8	Charge Pump	-	4Ch	-	○	-	2.2 x 2.2 (TBD)

ALC : Auto Luminous Control function (Ambient Light sensor I/F)

CPWM : CPWM is Current PWM solution that brings low noise in PWM brightness control

- Mass production
- New product
- Under development

Multi-function parallel & serial type for LCD back lighting

Features

- High Efficiency Serial DC/DC
- Switching FET integrated
- LED current accuracy +/- 1.5%
[BD6149/BD6150/BD6142A]
- Wide range input voltage
- Rich safety function integrated
- No sounding Capacitor by high speed response
- Low EMI by smoothing PWM switching

Block Diagram

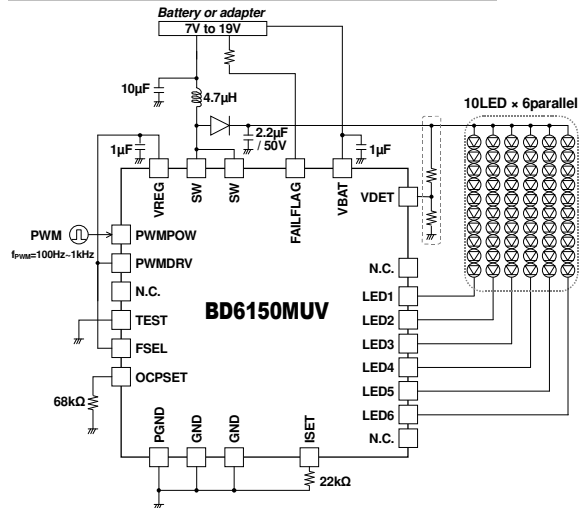

Line-up

Part No.	Back Lighting LED (Max.)			Switching FET	LED Current	Input Voltage[V]	Size [mm]
	Serial	Parallel	Max				
BD6066GU	12	4	48	External	30mA/Ch	2.7 - 22	2.6 x 2.6 CSP
BD6066EKN	12	4	48	External	30mA/Ch	2.7 - 22	5.1 x 5.1 QFN
BD6583MUV-A	12	6	72	External	25mA/Ch	2.7 - 22	4.0 x 4.0 QFN
BD6581GU	12	6	72	External	25mA/Ch	2.7 - 22	2.6 x 2.6 CSP
BD6592MUV	12	6	72	External	40mA/Ch	2.7 - 22	4.0 x 4.0 QFN
BD6586MUV	6	4	24	Internal	25mA/Ch	2.7 - 5.5	4.0 x 4.0 QFN
BD6150MUV	10	6	60	Internal	30mA/Ch	4.2 - 26	4.0 x 4.0 QFN
BD6590MUV	10	6	60	Internal	30mA/Ch	4.5 - 5.5	4.0 x 4.0 QFN
BD6142AMUV	10	8	80	Internal	30mA/Ch	4.2 - 27	4.0 x 4.0 QFN
BD65D00MUV	12	4	48	Internal	90mA/Ch	4.2 - 27	5.0 x 5.0 QFN

- Mass production
- New product
- Under development

LED Driver for Illumination & Decoration & Matrix Displays

Features

- Using the constant current driver (less scratchy)
- Integrated Illumination pattern
- 7bit (128step) current DAC
- Device Address select function
- High Efficiency Charge Pump (x1/x1.5/x2 mode)
- Sleep mode sequence
- Low Saturation Current Driver
- Small package
- Li-ion battery corresponded

Block Diagram

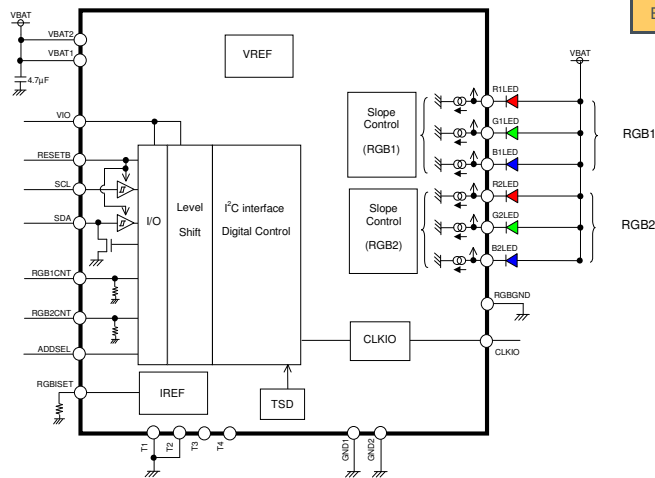

Line-up

Part No.	RGB Driver	Charge Pump	Wave Pattern	LED max Current	Other	Size [mm]
BD2606MUV	2Ch (6LEDs)	○	-	30mA/Ch	-	4.0 x 4.0 QFN
BD2802GU	2Ch (6LEDs)	-	Yes	30mA/Ch	-	2.8 x 2.8 CSP
BD2812GU	2Ch (6LEDs)	○	Yes	30mA/Ch	Sleep Mode	3.1 x 3.1 CSP
BD2804GUL	4Ch (12LEDs)	-	Yes	30mA/Ch	Sleep Mode	(TBD)
BD2801GUL	1Ch (3LEDs)	-	-	60mA/Ch	-	(TBD)
BH6948GU	7 x 7 Matrix	○	Slope	31mA/Line	-	4.1mm□CSP
BD26502GUL	7 x 17 Matrix	-	Scroll, Slope	20mA/Line	(RAM x2)	4.1mm□CSP
BD26503GUL	7 x 17 Matrix	-	Scroll, Slope	30mA/Line	(RAM x2)	3.6mm□CSP
BD26503KS2						SQFP-T52
BDU6507GUL	5 x 6 Matrix	-	Slope	42.5mA/Line	(RAM x2)	2.5mm□CSP(TBD)
BU16501KS2	8x 16 Matrix	-	-	42.5mA/Line	(RAM x1)	SQFP-T52
BU16501GWL						CSP (TBD)

- Mass production
- New product
- Under development

LED Driver for Indicators

Features

- High voltage on LED pin
- 80mA/Ch open drain driver
- 6bit PWM brightness control
- 4bit Device address selectable
- I2C 1MHz or 2-wire 2MHz I/F
- High power package

Block Diagram

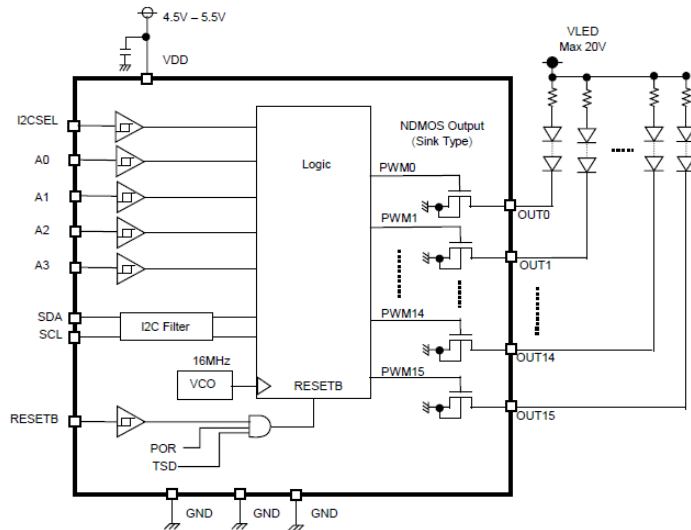

Line-up

Part No.	Channel	Maximum Output Current	Solution	Brightness Control	Max Voltage	I/F	Package
BD7851FP	16	80mA/Ch	Constant current driver	ON/OFF	10V	4-wire	HSOP-25
BD7844AEFV	16	80mA/Ch	Open drain	PWM 8bit	20V	I2C	HTSSOP-B28
BD7853EFV	16	50mA/Ch	Constant Current driver	ON/OFF	20V	3-wire	HTSSOP-B24
BD78H24EUV	24	50mA/Ch	Constant Current driver	DAC 6bit PWM 8bit	20V	2-wire	HTSSOP-B48

Mass production
 New product
 Under development

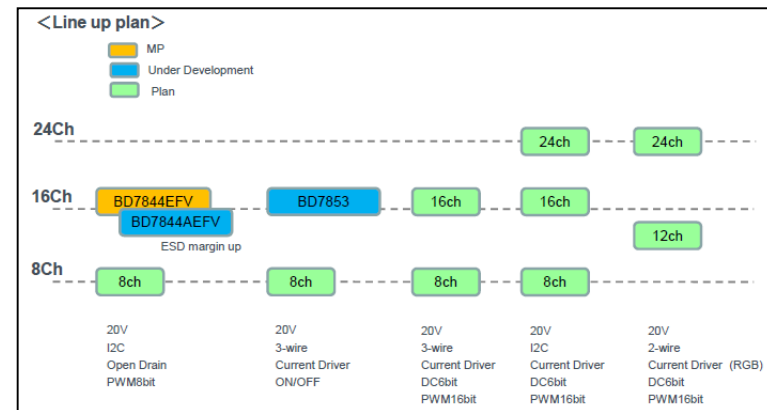

Flash LED Driver for Flash/Torch Lighting

Features

- High Efficiency Charge pump
- High Efficiency Charge pump
- Flash Timer integrated [BD7700/BD6062]
- 4Ch LDO for Camera integrated [BD6085]
- Small package
- Li-ion battery corresponded

Block Diagram

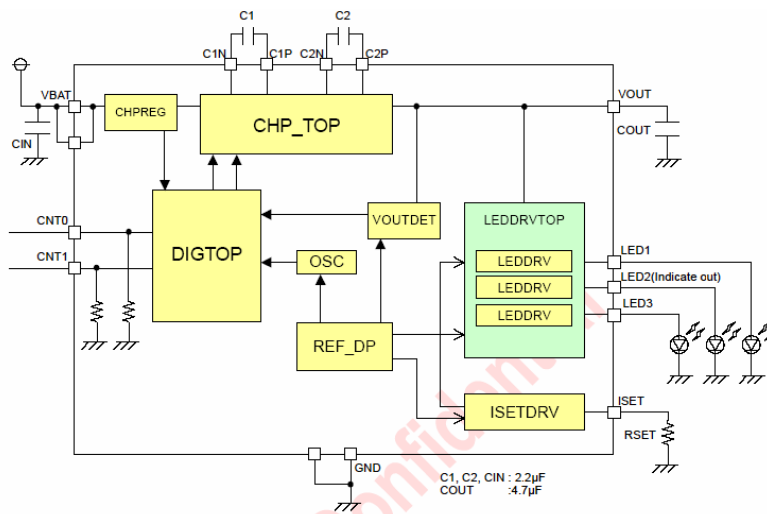

Line-up

Part No.	Maximum Output Current	Solution	Other	I/F	Size [mm]
BD1603NUV	190mA(Vo=4.5V)	Charge Pump	-	I2C	3.0 x 3.0 QFN
BD7700GU	300mA (Source type)	Charge Pump	Flash Timer	EN	2.24 x 2.24 CSP
BD6085GUL	480mA	Charge Pump (x1.33 mode)	LDO 4Ch	I2C	3.3 x 3.3 CSP
BD6062GU	1A	DC/DC	Flash Timer	SCI	2.86 x 2.86 CSP
BD7704MUX	1.5A (750mA x 2) (Source type)	DC/DC	Flash Timer	UPIC+	3.0 x 3.0 QFN
BD7705GUL	1.5A (750mA x 2) (Source type)	DC/DC	Flash timer	I2C	1.7 x 1.7 (TBD)
BD7274FUJ	2.4A (600mA x 4ch) (Source type)	-	-	EN	TSSOP-C10J

- Mass production
- New product
- Under development

Features

- Vin(AC) : 80Vac – 270Vac
- 2W – 30W output power
- High efficiency Step Down AC/DC
- Bleeder function
- 3-way dimming (Triac/Linear/PWM)
- Small package

Line-up

Part No.	Vin(AC)	Output Power	Dimming control			Package
			Triac	Linear	PWM	
BD555AKFV	80V – 270V	2W – 30W	○	○	○	SSOP-B14
BD555BKFV			○	-	○	SSOP-B14
BD555A1KFV	80V – 270V	2W – 30W	-	○	○	SSOP-B14
BD555AAKFV	80V – 270V	2W – 30W	-	-	-	SSOP-B14

Mass production
 New product
 Under development

Block Diagram

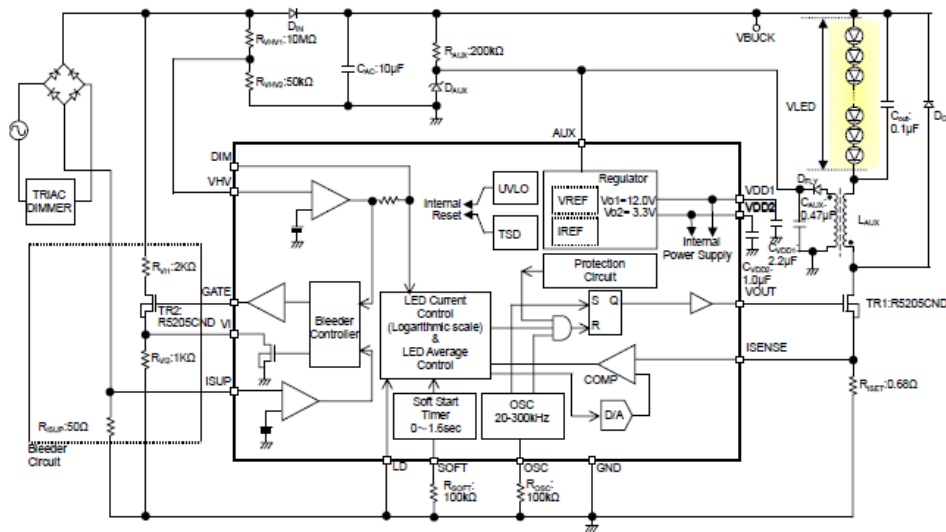

Application Example: White Goods

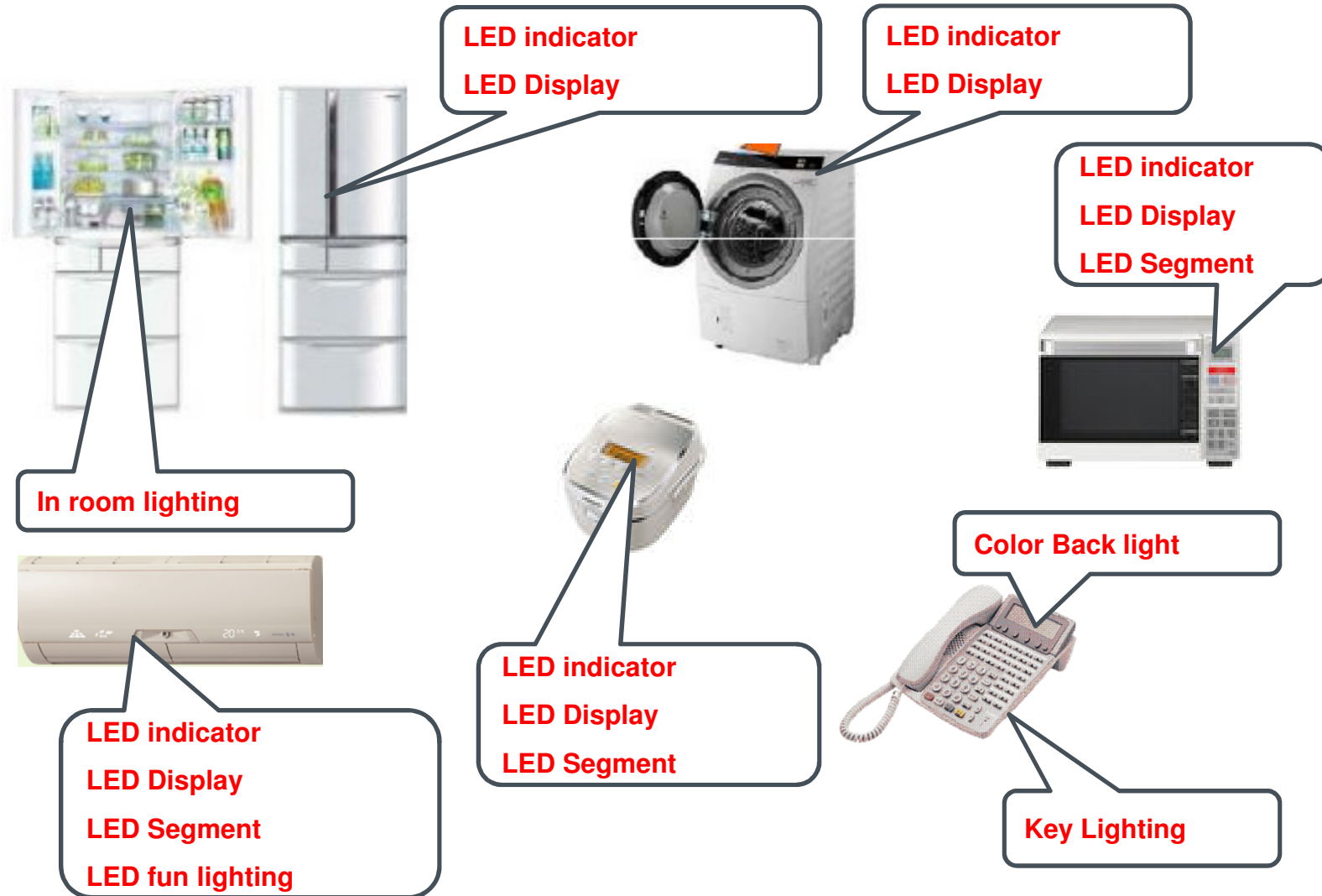

Application Example: Mobile

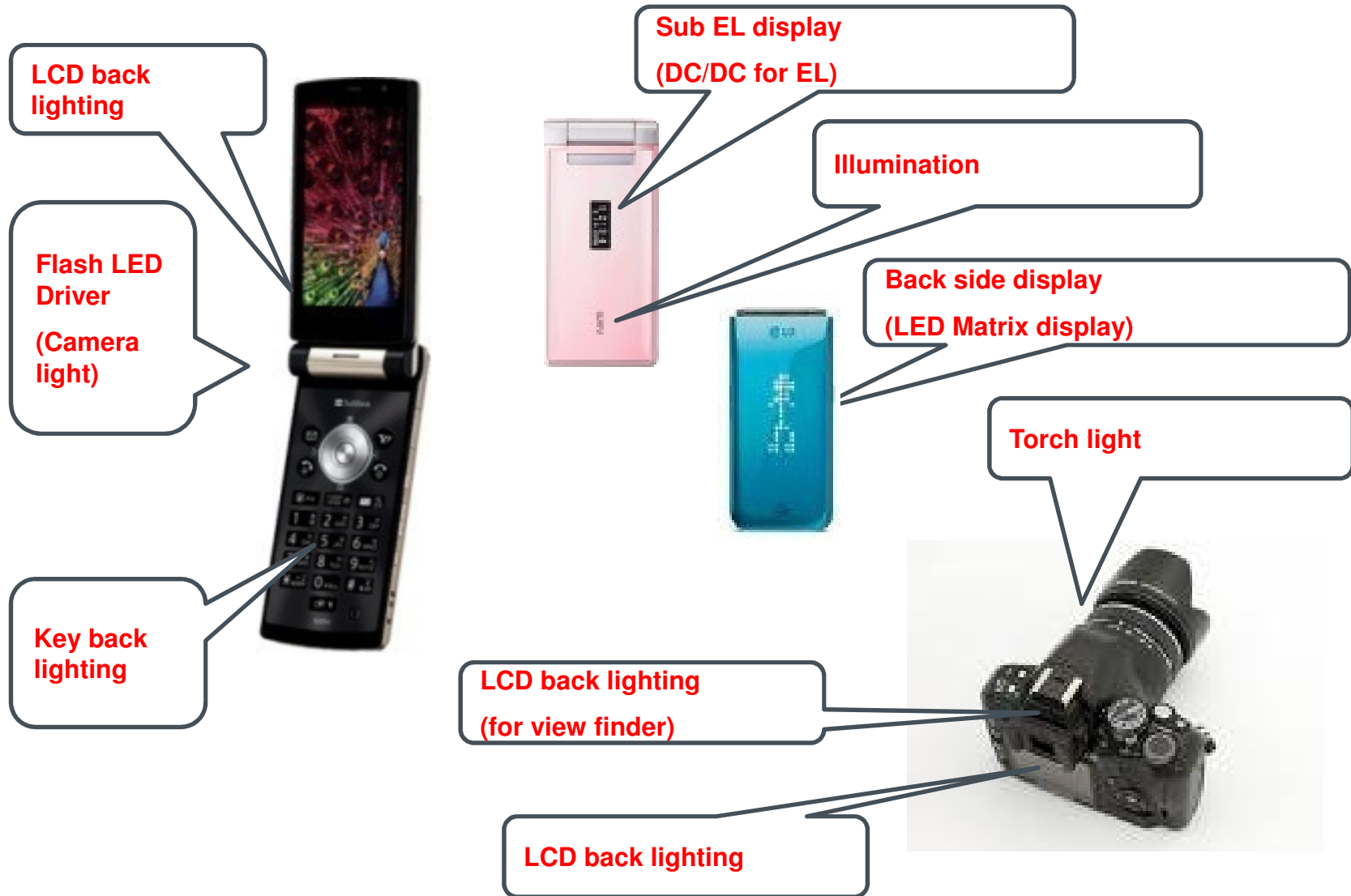

LED Drivers – High Reliability LineUp

LED Drivers – High Reliability LineUp

- **Multichannel step-up, step-down LED driver**
- **Step-up, step-down LED Driver for Display Backlighting**
- **High Power step-up, step-down LED driver**
- **Linear Type LED Driver**

Multichannel step-up, step-down LED driver

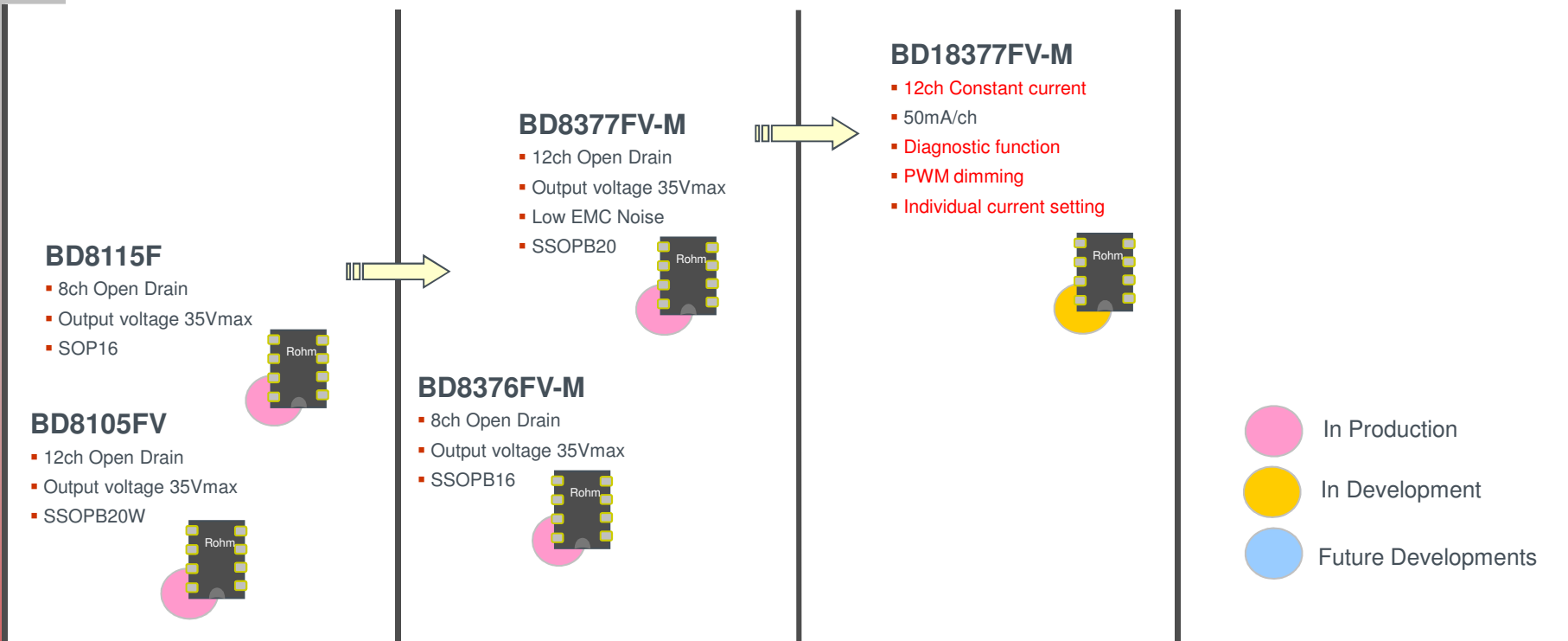

0.6um Bi-CDMOS		0.35um Bi-CDMOS						
~2010		2011		2012		2013		
Part Number	Channel Number	Maximum Input Voltage	Maximum Output Voltage	ON Resistor	Serial Clock Frequency	Drive Current	Package	Status
BD8105FV	12ch	7V	35V	6Ω	1MHz	50mA	SSOP-B20W	MP
BD8115F	8ch	7V	35V	6Ω	1.25MHz	50mA	SOP-16	MP
BD8376FV	8ch	7V	35V	6Ω	1.25MHz	50mA	SSOP-B16	MP
BD8377FV	12ch	7V	35V	6Ω	1.25MHz	50mA	SSOPB20	MP
BD18377EFV	12ch	7V	20V	6Ω	1.25MHz	50mA	HTSSOP-B20	DS available

BD8377 (12ch); BD8376 (8ch)

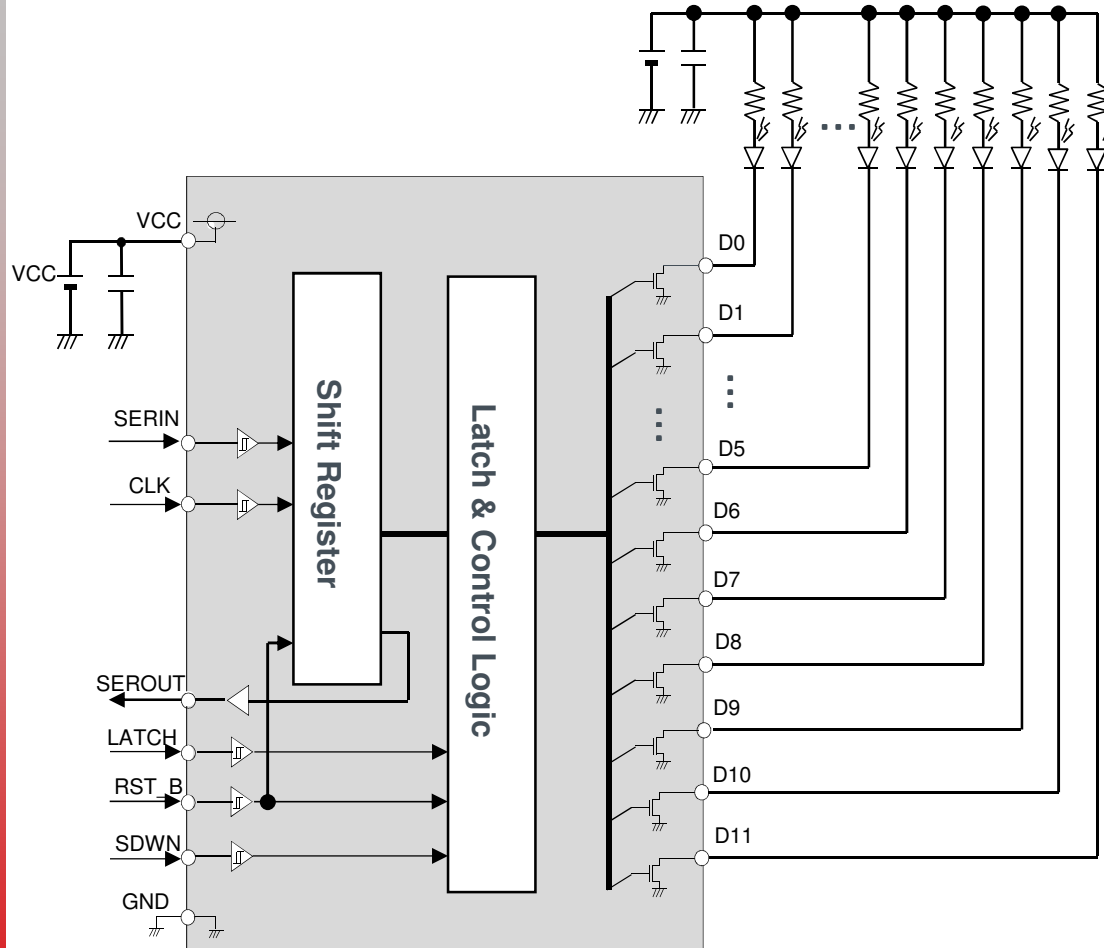

BD8377FV Features

- 12bit Serial-in / Parallel-out I/F
- 35V DMOS Open Drain Output
- Max. Current 50mA/ch (DC)
- Max. Current 150mA/ch (Pulse)
- Ron of Power MOSFET 6Ω(typ)
- Cascade connection possible
- Output slew rate 20V/usec
(For low EMC noise)
- SSOP-B20 small package

BD8376FV Features

- 8bit Serial-in / Parallel-out I/F
- Small SSOP-B16 package

BD18377 (12ch)

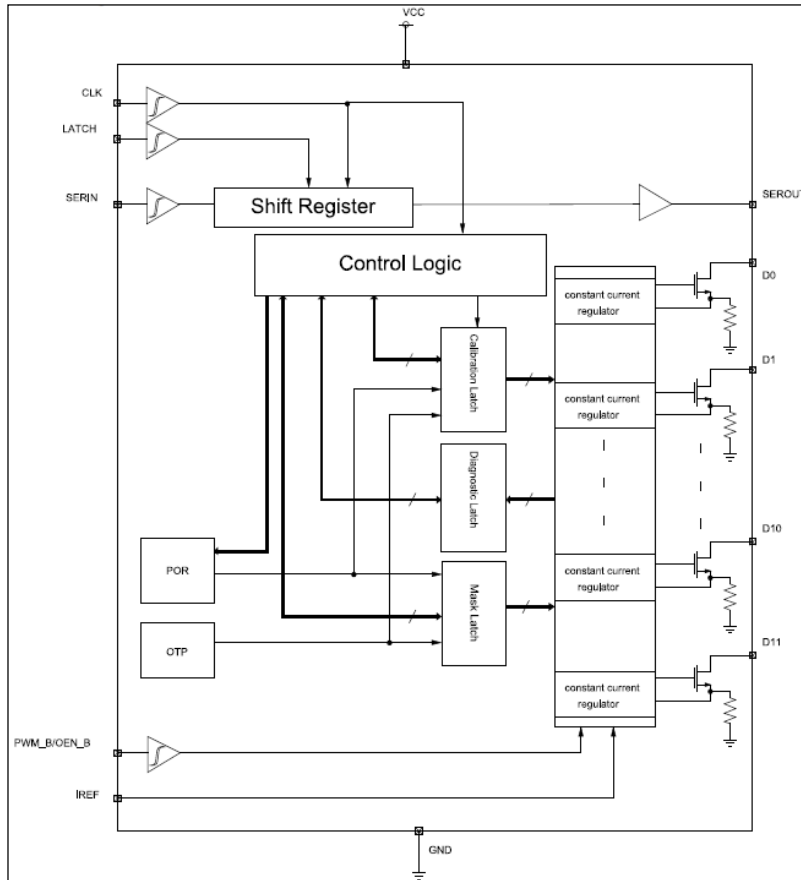

BD18377 Features

- 12bit
Serial-in / Parallel-out I/F
- Enable pin
- 20V Output Voltage
- **Constant Output Current 5 to 50mA/ch
+/-3% accuracy**
- **Global dimming (0.1-100%) and LED
brightness adjustment per channel
(1.6-100% in 1.6% steps / 6bit)**
- **Diagnostic output on LED status
(OPEN, SHORT) for each channel and
global ANY_OPEN / ANY_SHORT
(with mask)**
- Cascade connection possible
- Output slew rate for low EMC noise
- HTSSOP-B20 small package

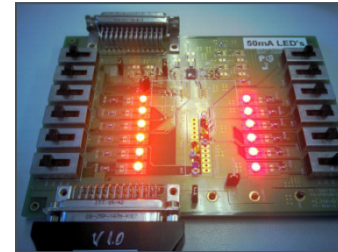

Step-up, step-down LED Driver for Display Backlighting

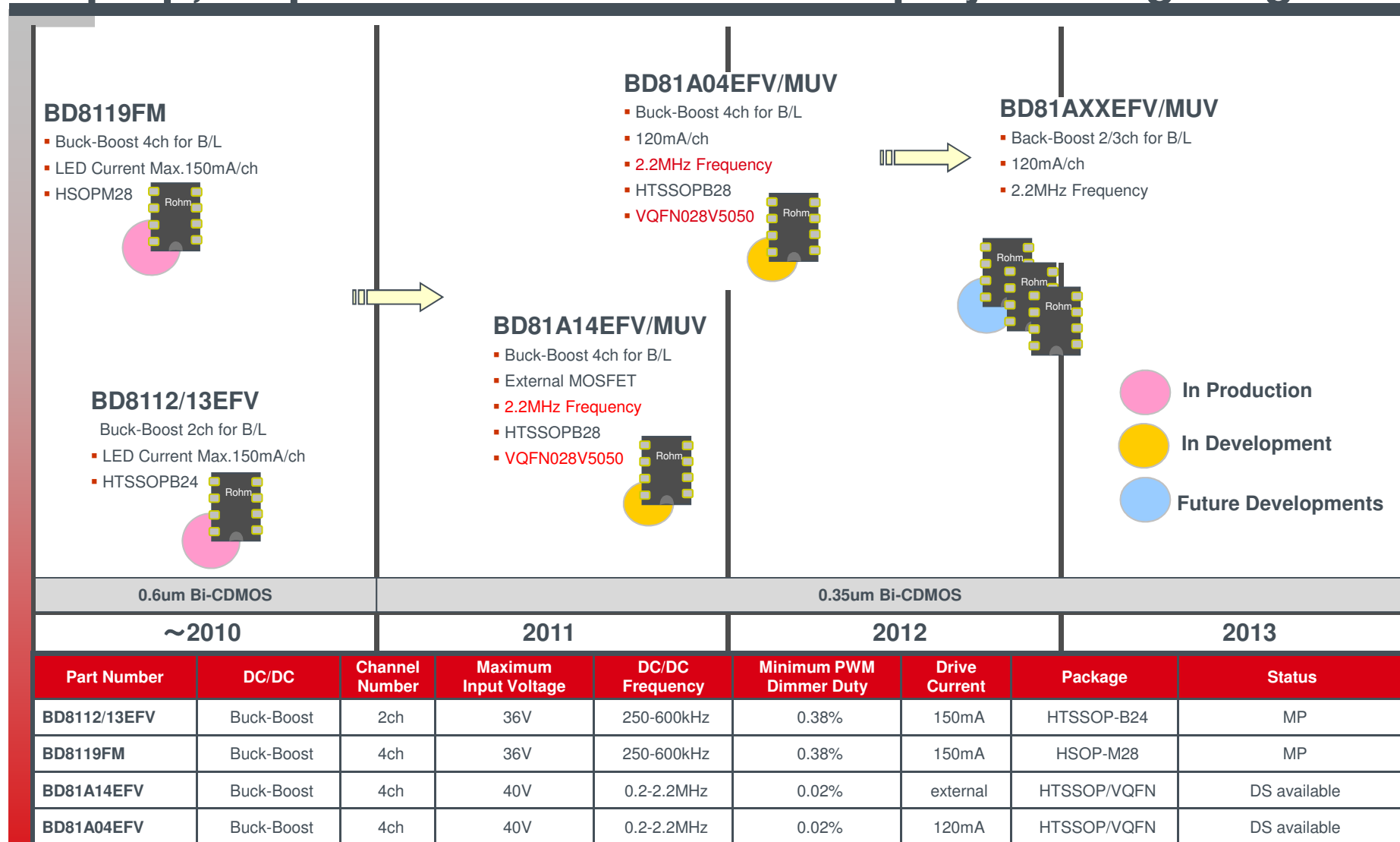

BD8112/13 (2ch)

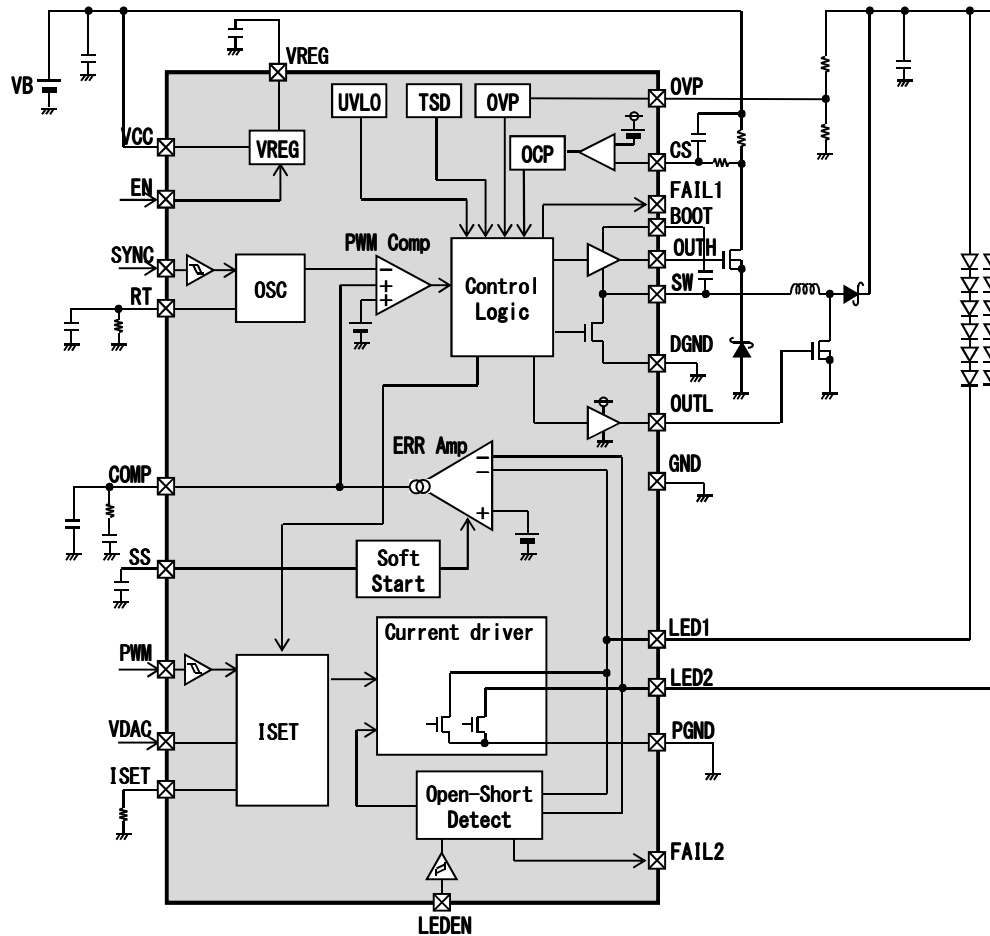

BD8112EFV Features

- **Buck-boost DC/DC converter**
- Output current : $I_{\text{omax}}=150\text{mA/ch}$
- Wide operating voltage : $5.0\sim 30\text{V}$
- 2ch constant current output
Current matching : 3%)
- PWM Dimmer : $0.38\sim 100\%$ @150Hz
- **Linear Dimmer possible**
- UVLO / OVP / TSD / OCP
- Short Circuit Protection
- LED open/short protection
- Frequency accuracy : $\pm 5\%$
- Package : HTSSOP-B24

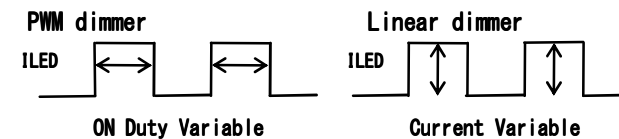

BD81A11EFV/MUV-M

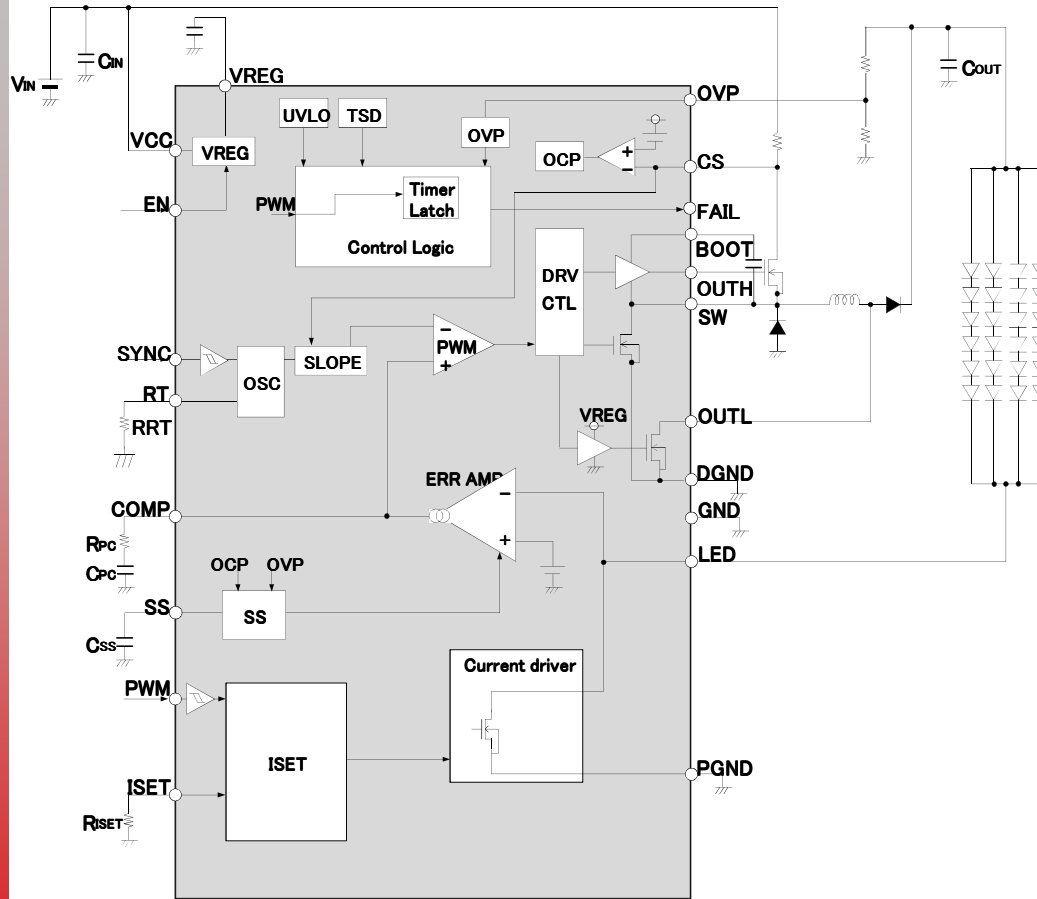

BD81A11EFV-M Features

- Correspond to **Boost and Buck-boost (Integrated Boost FET)**
- Output current : **$I_{omax} = 400mA$**
- Wide operating voltage range : **4.5~30V**
- 1ch constant output current (Current accuracy : 3%)
- **PWM dimming control : 0.01~100% @100Hz**
- UVLO circuit / OVP / TSD / OCP
- LED anode / cathode (SCP)
- **Oscillating frequency accuracy : $\pm 5\%$**
- Package HTSSOP-B20 or VQFN028V5050

PWM dimming control

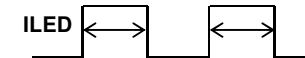

ON Duty controllable

BD81A04EFV-M/MUV-M (4ch)

BD81A04EFV-M/MUV-M Features

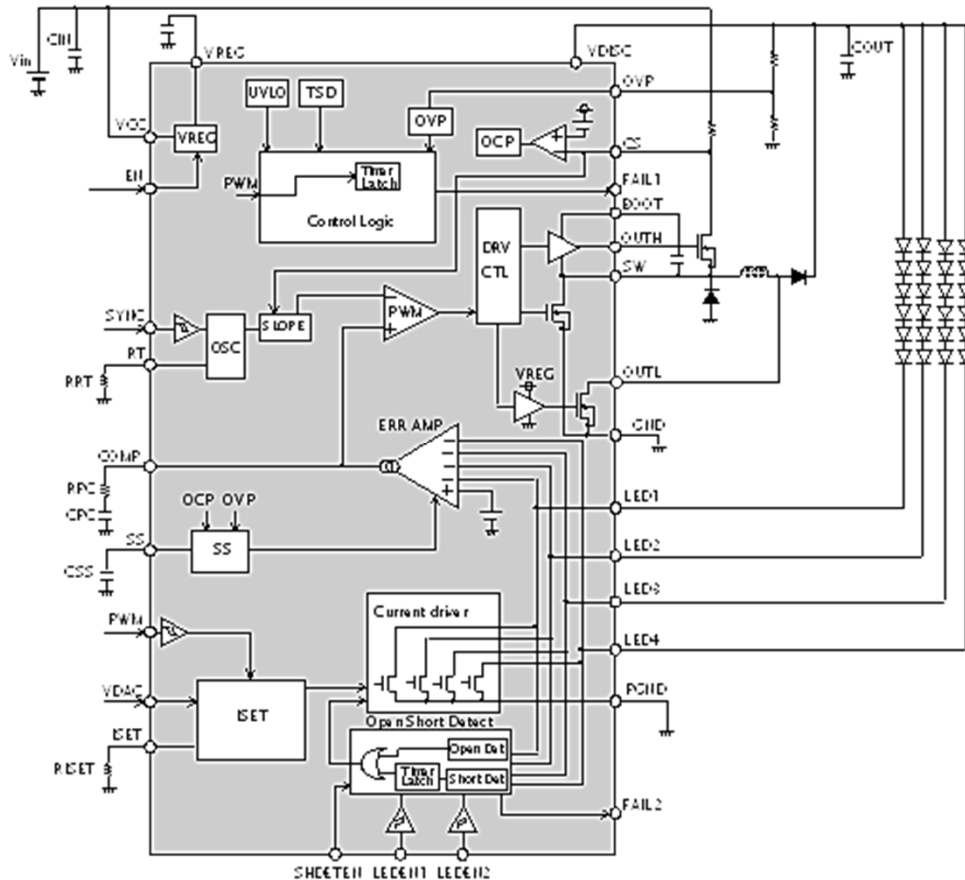

- Correspond to **Boost** and **Buck-boost** (Integrated Boost FET)
- Output current : $I_{o\ max} = 120\text{mA}$
- Wide operating voltage range : 4.5~30V
- **4ch** constant current output (Current accuracy : 3%,)
- **PWM dimming control: 0.01~100% @100Hz**
- UVLO circuit / OVP / TSD / OCP
- LED anode / cathode (SCP)
- LED open / short protection (short detection ON/OFF function)
- **Oscillating frequency accuracy : $\pm 5\%$**
- Package : HTSSOP-B28 or VQFN028V5050

PWM dimming control

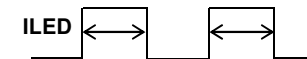

ON Duty controllable

VDAC(linear) dimming control



Current controllable

High Power step-up, step-down LED driver

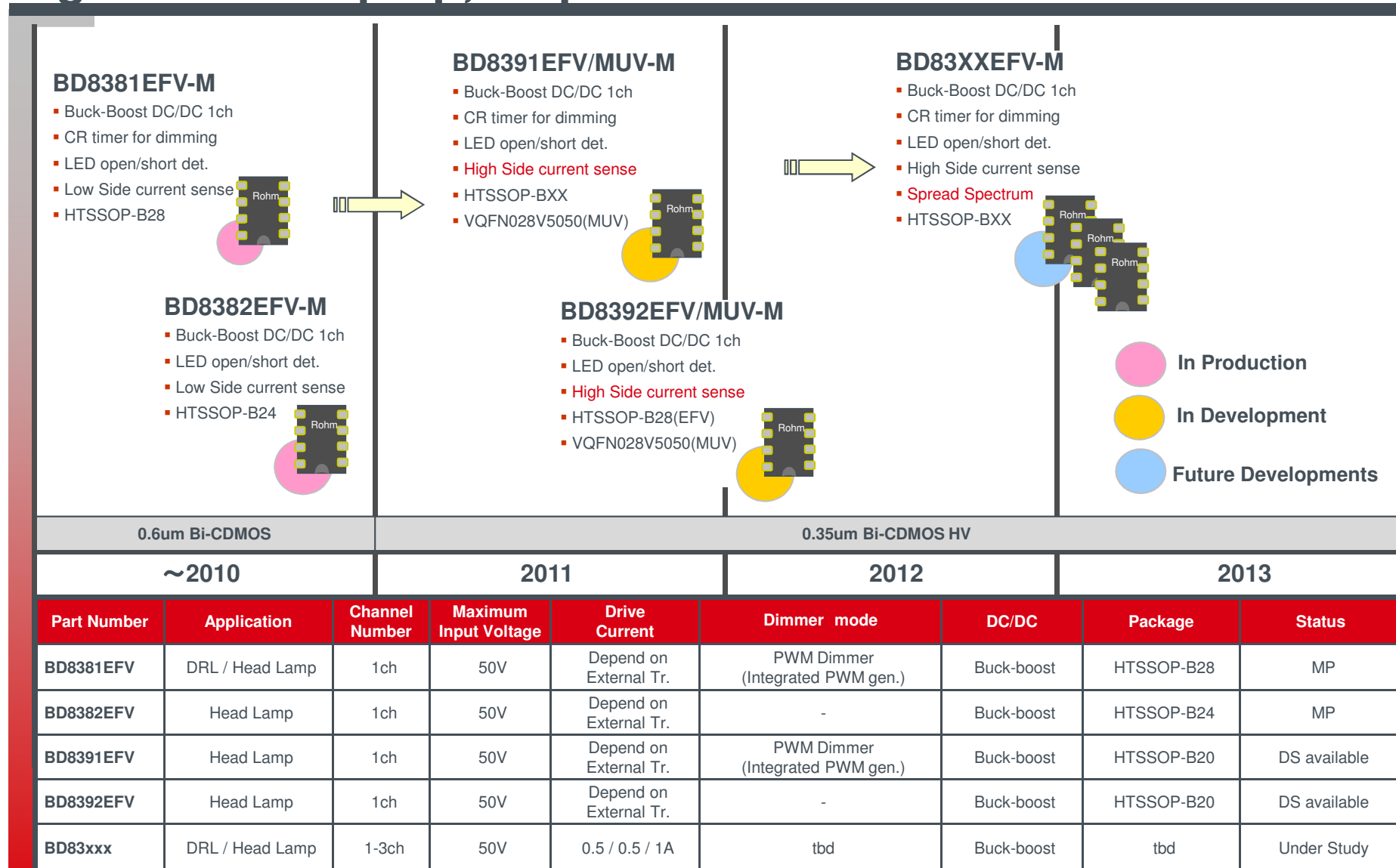

BD8381EFV

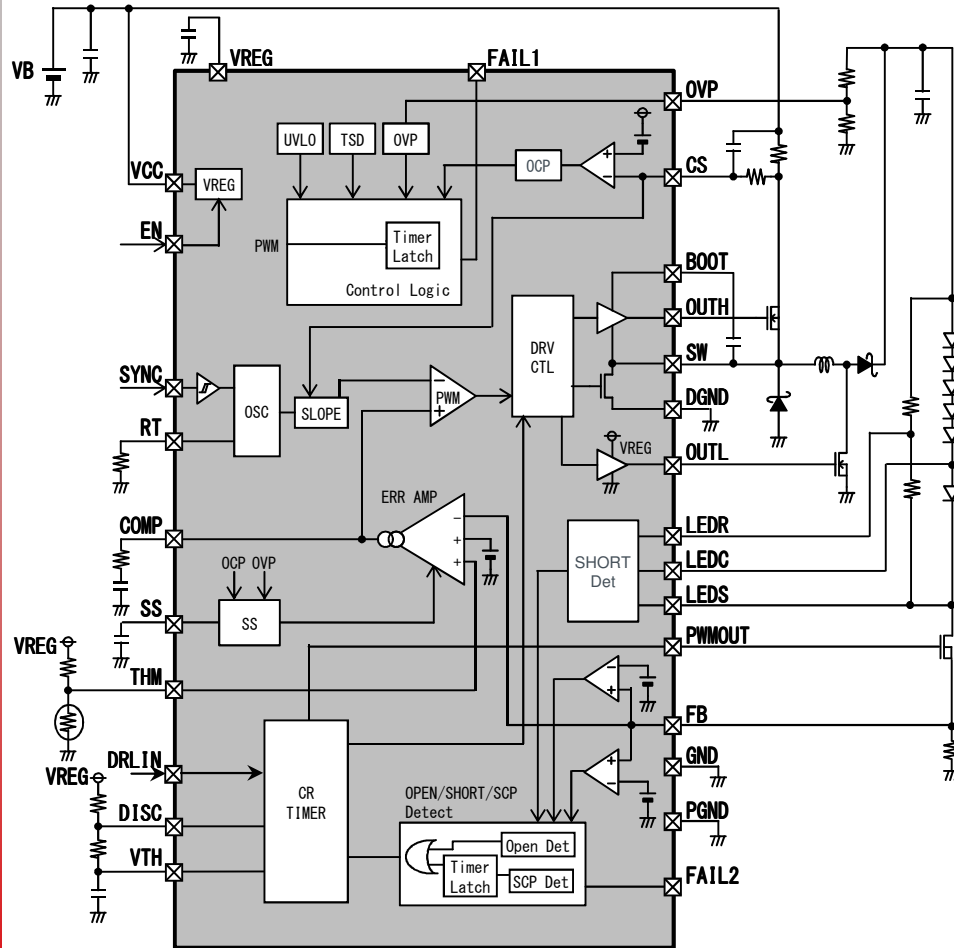

BD8381EFV

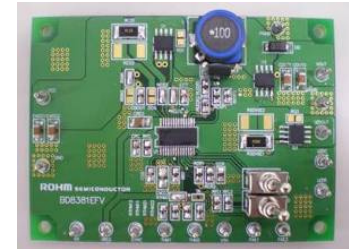

- Buck-boost DC/DC converter
- Wide input voltage range : 5.0~30V
- Constant voltage output (FB) : 0.2V
- **Brightness control by PWM or DC (PWM brightness range : 2~100%)**
- **Integrated PWM signal generator : 2~45% (brightness control is possible with external CR)**
- Switching frequency : 100kHz~600kHz
- UVLO/ OVP / TSD / OCP
- Shortcut Protection for LED anode / cathode
- Protection for LED open / short
- Package : HTSSOP-B28

BD8381 Features I

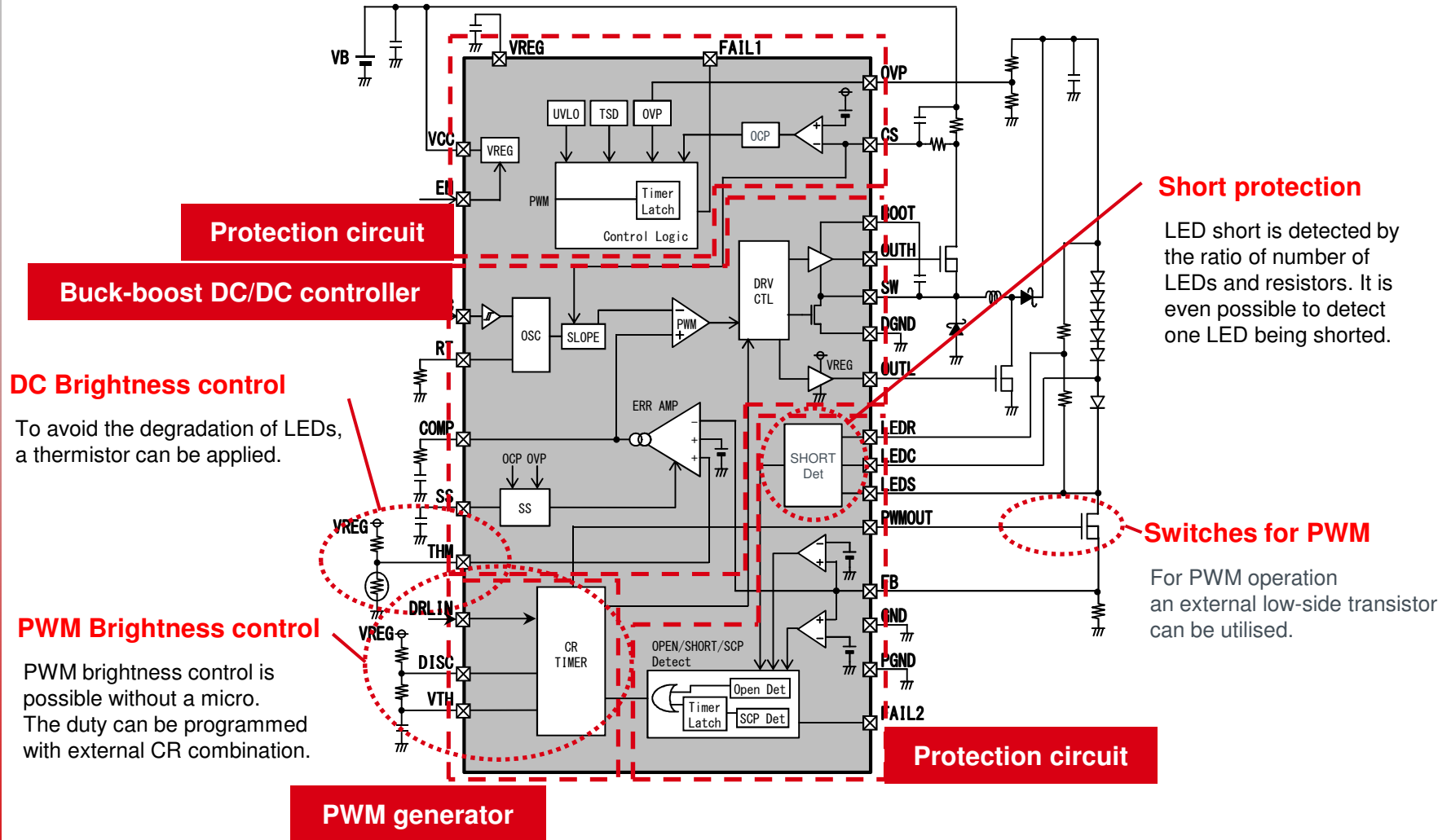

Protection circuit

Buck-boost DC/DC controller

DC Brightness control
To avoid the degradation of LEDs, a thermistor can be applied.

PWM Brightness control
PWM brightness control is possible without a micro. The duty can be programmed with external CR combination.

PWM generator

Short protection

LED short is detected by the ratio of number of LEDs and resistors. It is even possible to detect one LED being shorted.

Switches for PWM

For PWM operation an external low-side transistor can be utilised.

Protection circuit

BD8381 Features II

Rohm REGSPIC via SEPIC Comparison

If point A short to GND, Input will directly run through to output.
Need Pch load switch to protect.

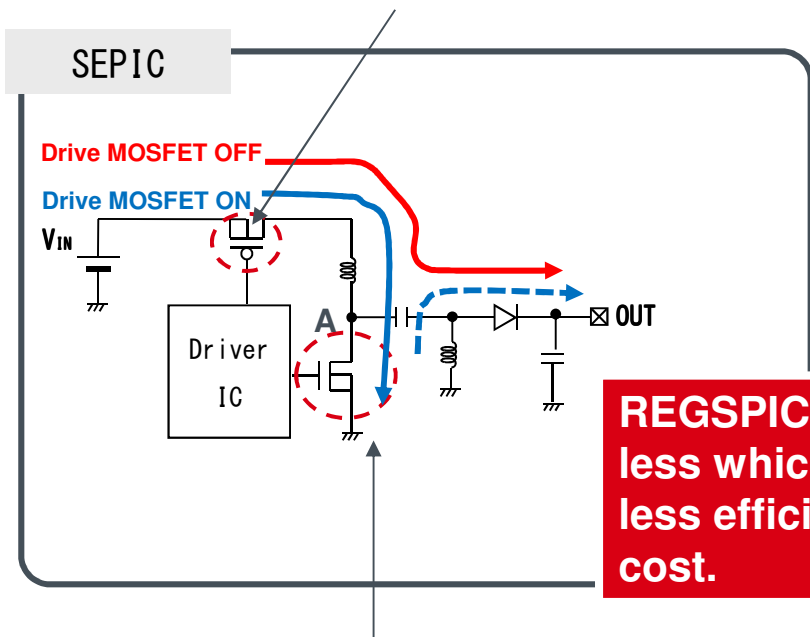

$V_{in} + V_{out}$ will be applied at Switch ON/OFF. Needs high voltage MOSFET.

When abnormality is detected, Input will be blocked at Buck Hi SideFET. No external FET necessary for protection.

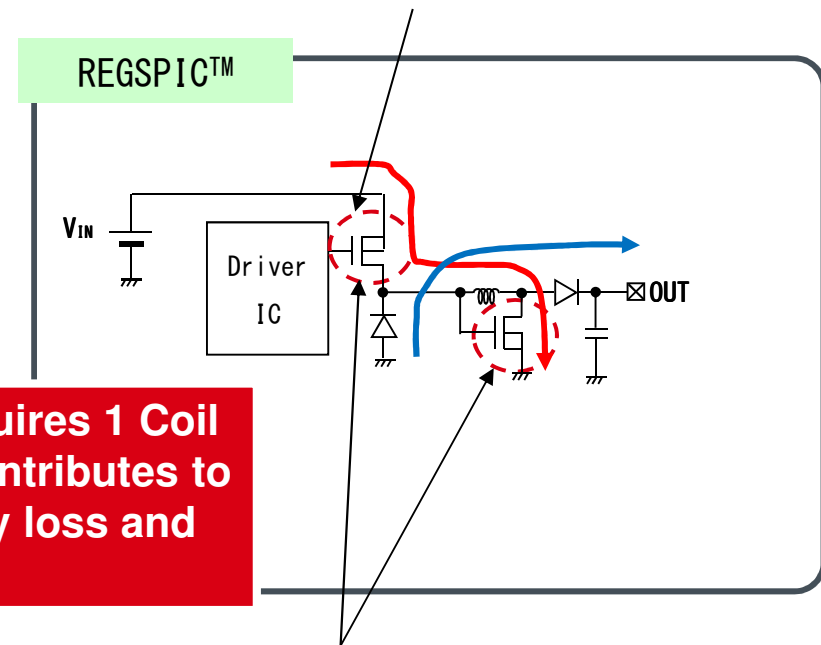

REGSPIC requires 1 Coil less which contributes to less efficiency loss and cost.

MOSFET will be sufficient to handle higher voltage of either V_{in} or V_{out} .

BD8391EFV/MUV-M

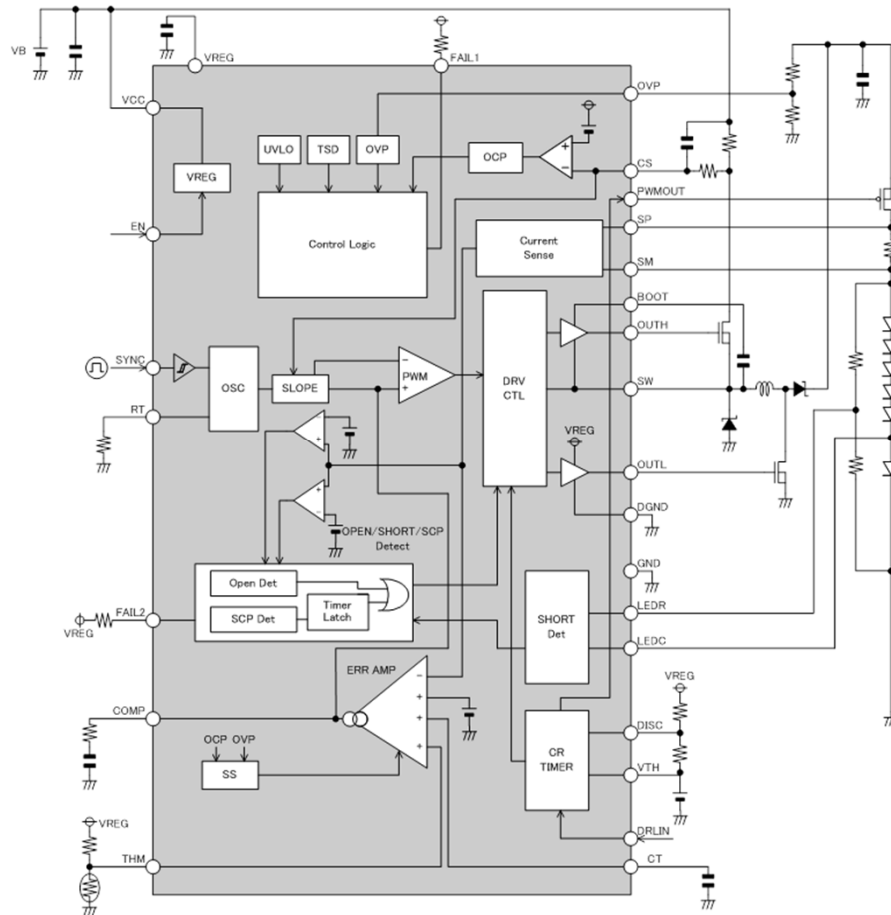

BD8391EFV/MUV Features

- Buck-boost DC/DC converter
- Wide input range : 5.0~30V
- Constant voltage output : 0.2V
- High-side Current-Sensing
- Brightness control by PWM or DC
(PWM brightness range : 2~100%)
- Integrated PWM signal generator : 2~45%
(brightness control is possible with external CR)
- Switching frequency : 200kHz~600kHz
- UVLO/ OVP / TSD / OCP
- SCP for LED anode / cathode
(SCP protects LED anode / cathode short to GND)
- Protection for LED open / short
(LED SHORT detects LED)
- Package : HTSSOP-B28

BD8392EFV-M

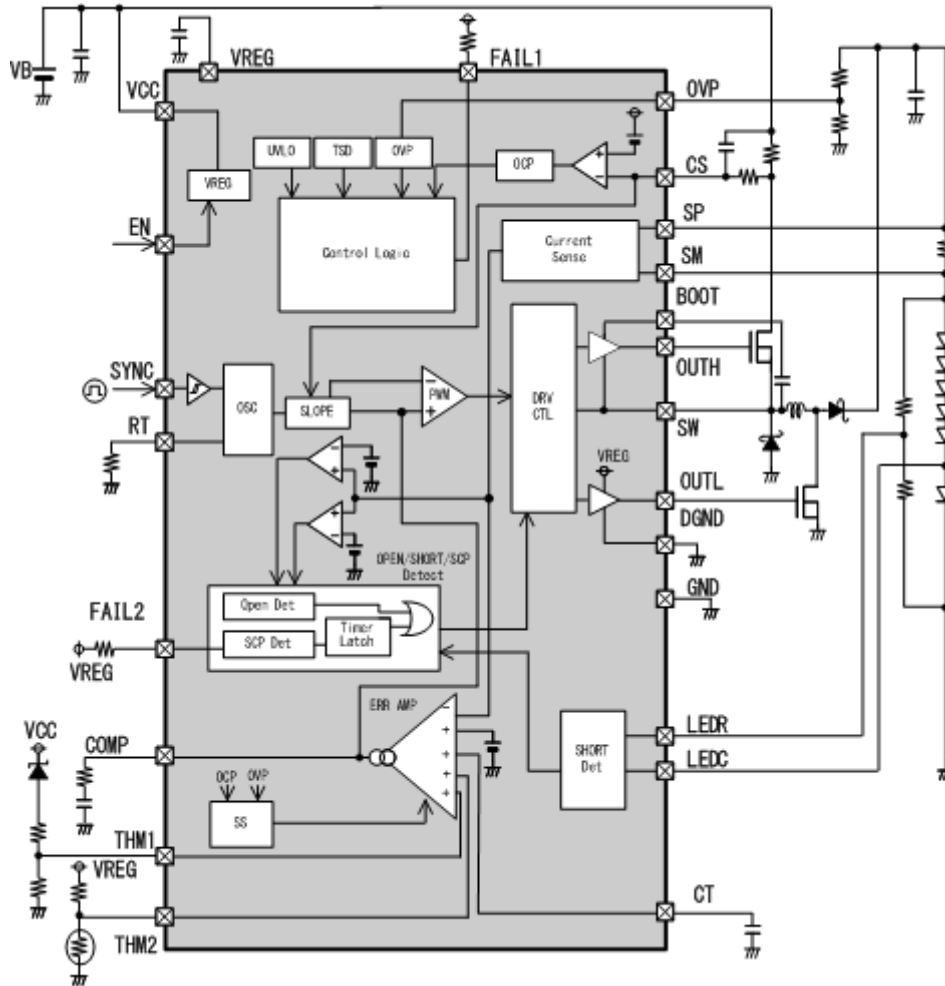

BD8392EFV Features

- High Side current sense
- Buck-boost DC/DC converter
- Wide input range : 5.0~30V
- Constant voltage output : 0.2V
- Integrated DC brightness control
- Switching frequency : 200kHz~600kHz
- UVLO/ OVP / TSD / OCP
- SCP for LED anode / cathode
- Protection for LED open / short
- Package : HTSSOP-B28

Linear Type LED Driver

BD8371HFP/EFJ-M

- Programmable Current 1ch
- LED open/short det.
- I_{max} = 150mA
- HRP-7(HFP)
- HTSOP-J8(EFJ)



BD8374HFP-M

- Programmable Current 1ch
- CR timer / dimmer
- LED open/short det.
- I_{max} = 500mA
- HRP-7

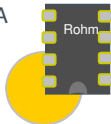

BD8372HFP/EFJ-M

- Programmable Current 1ch
- LED open/short det.
- I_{max} = 200mA
- HRP-7(HFP)
- HTSOP-J8(EFJ)



Switching type BD83XXEFV-M

- Buck-Boost DC/DC 1ch/2ch/3ch
- CR timer for dimming
- LED open/short det.
- High Side current sense
- HTSSOP-BXX

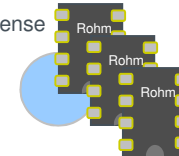

- In Production
- In Development
- Future Developments

0.6um Bi-CDMOS

0.35um Bi-CDMOS HV

~2010

2011

2012

2013

Part Number	Application	Channel Number	Maximum Input Voltage	Drive Current	Dimmer mode	DC/DC	Package	Status
BD8371HFP/EFJ	Turn / Rear Lamp	1ch	50V	150mA	High / Low current	-	HRP-7 / HTSOP-J8	MP
BD8372HFP/EFJ	Turn / Rear Lamp	1ch	50V	200mA	High / Low current	-	HRP-7 / HTSOP-J8	MP
BD8374HFP	Turn / Rear Lamp	1ch	50V	500mA	PWM Dimmer (Integrated PWM signal generator)	-	HRP-7	DS available

BD8372EFJ/HFP

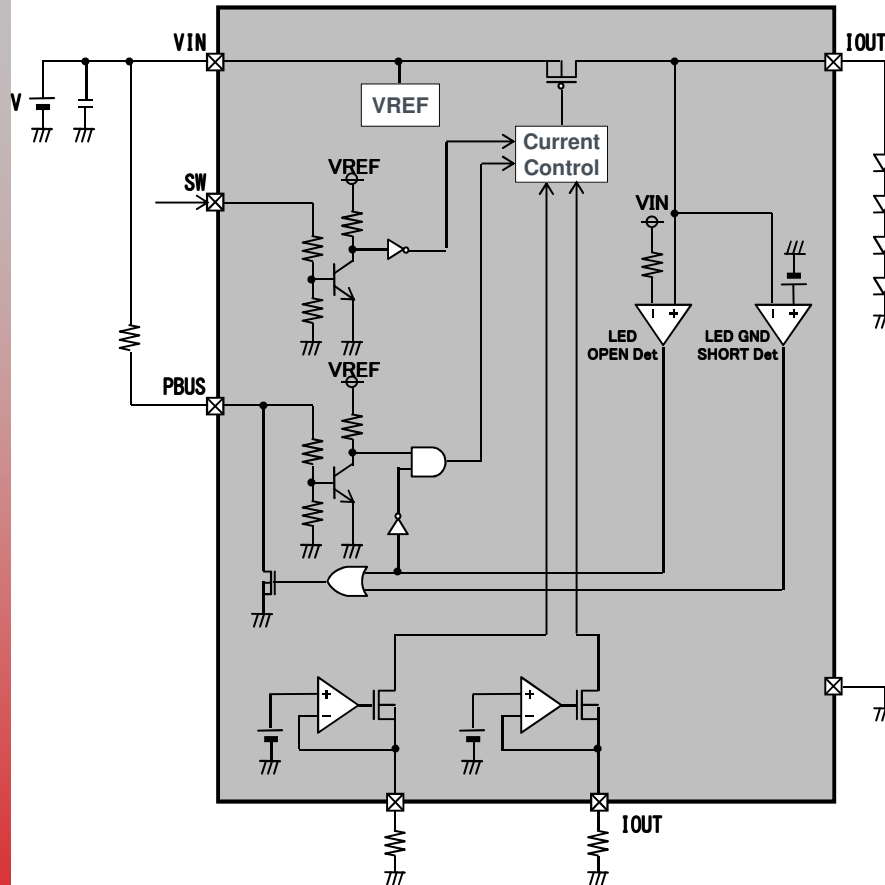

BD8372EFJ/HFP Features

- **Selectable constant current source driver**
- **Output current $I_{omax}=200mA$**
- **Individual settings for low- and high-current**
- **Wide input voltage range (6.0~40V)**
- **Current tolerance $\pm 3\%$**
- **UVLO / TSD protection**
- **LED open / short protection**
- **PBUS function (Diagnostics)**
- **Package : HRP-7 / HTSOP-J8**

LDO Type Driver

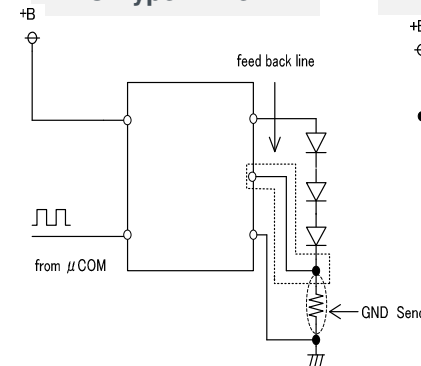

BD8372(Current Source Driver)

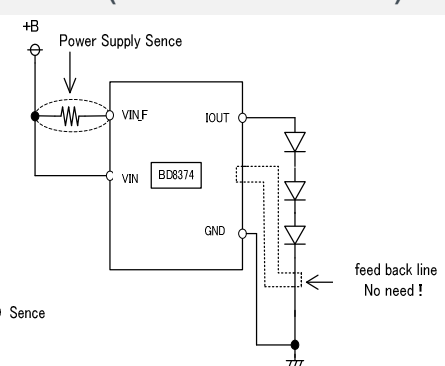

Eliminate wiring contributes to your cost reduction

BD8372 - Features

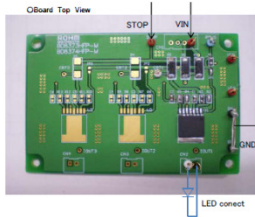

Protection circuit

High-side constant current output

The output is constant current source type. This block integrates a function which the output current is reduced while high voltage input is applied, so that less heat would be generated during the malfunction.

LED open/short protection

PBUS generates a warning signal when malfunction occurs

PBUS Function

As the number of LEDs depends on car models, we integrated the PBUS for applications having multiple drivers in the system

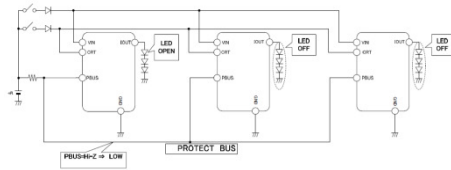

Setting constant current

The current settings for normal-mode and brake-mode can be individually configured.

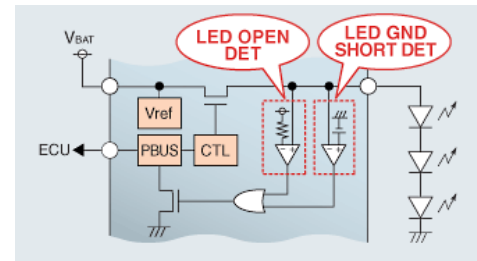
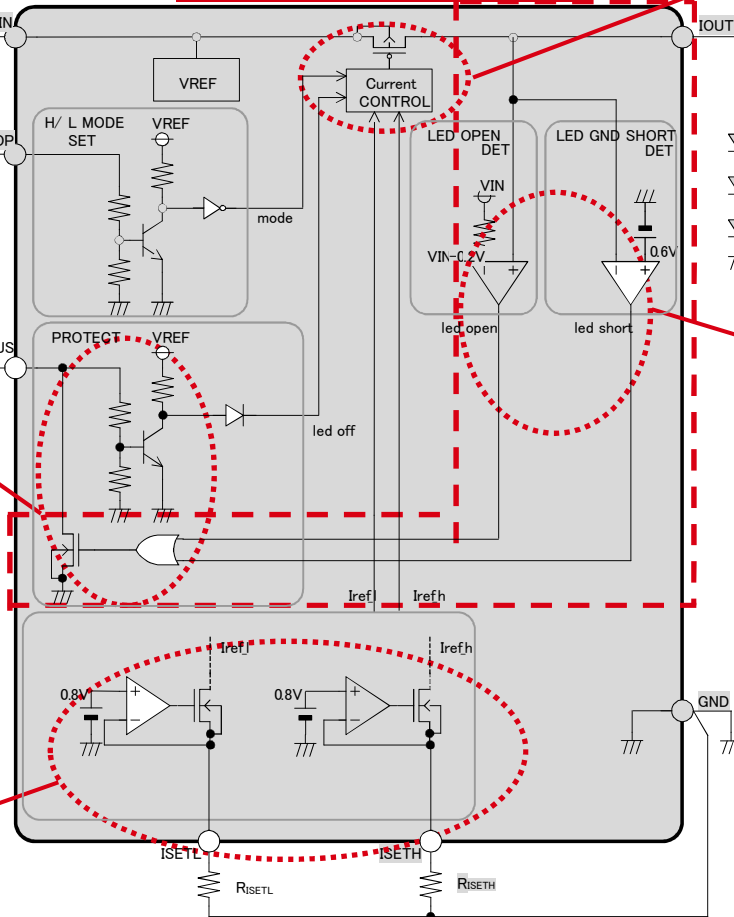

BD8374HFP-M

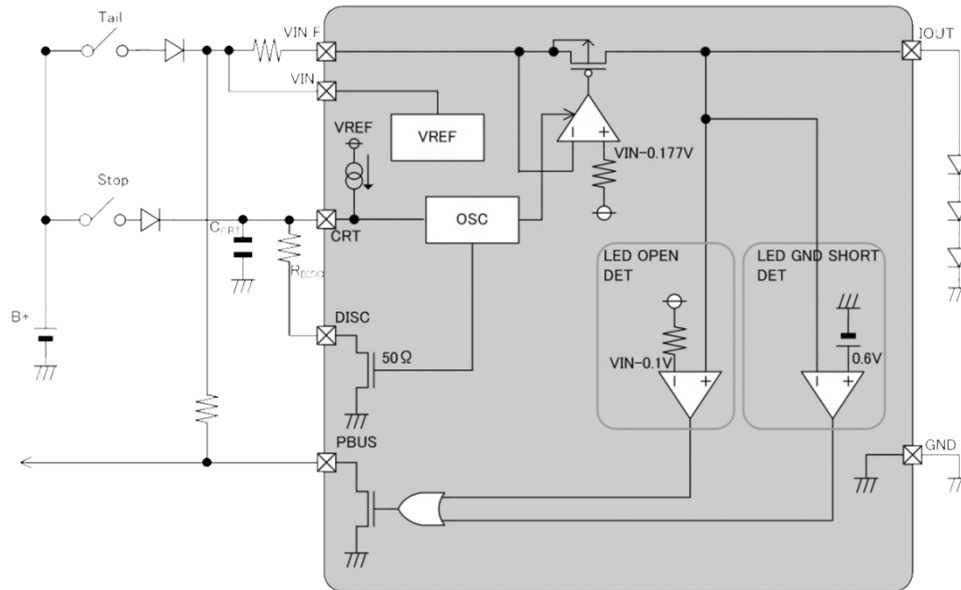

BD8374HFP Features

- **Selectable constant current source driver**
- **Output current**
 - BD8373HFP/EFJ-M $I_{\text{max}}=300\text{mA}$
 - BD8374HFP-M $I_{\text{max}}=500\text{mA}$
- **Brightness control by PWM or DC**
(PWM brightness range : 1~100%)
- **Integrated PWM signal generator : 1~45%**
(brightness control is possible with external CR)
- **Wide input range : 5.5~42V**
- **Tolerance of I_o : $\pm 5\%$**
- **UVLO / TSD protection**
- **LED open / short protection**
- **PBUS function (Diagnostics)**

BD8374 - Features

Integrated PWM Signal Generator

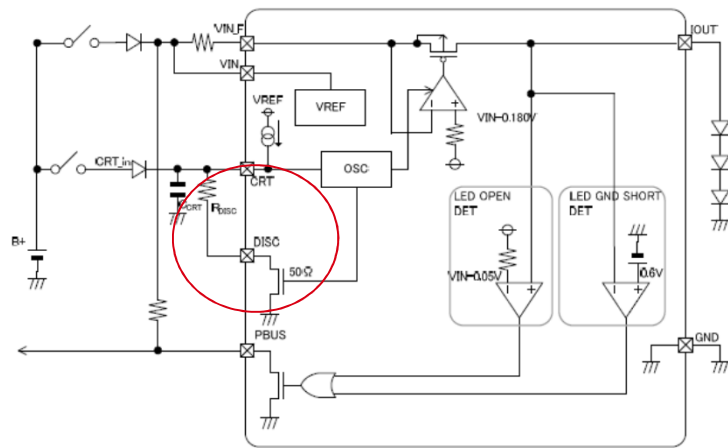

PWM input Adjustable with Capacitor and Resistor

Integrated Protection

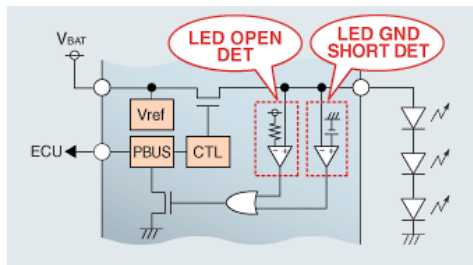

OBD8374FP-M Application Board Circuit

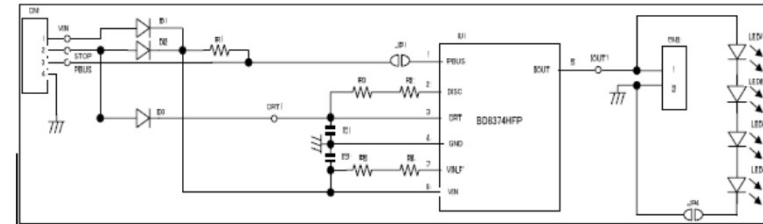

OBoard Top View

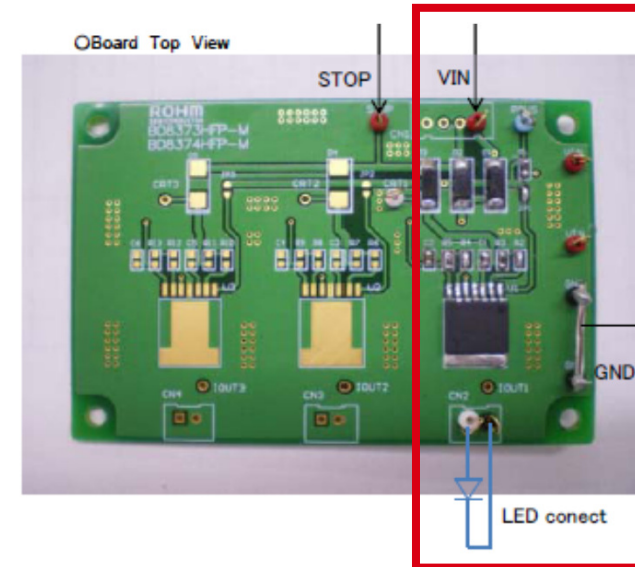

...Compact solution with only few external components!

Application Example: Automotive

Indicators	
Function	Serial-in parallel-out driver
P/N	BD8115 (8ch) BD8376 (8ch) BD8105 (12ch) BD8377 (12ch) BD18377 (12ch)

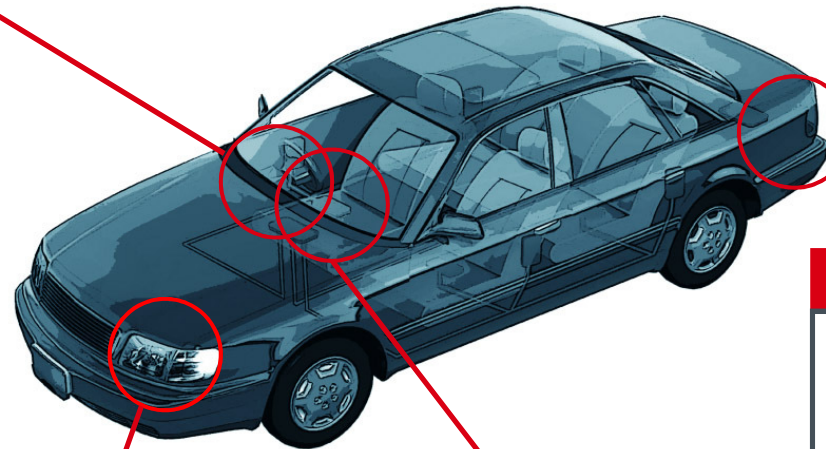

Rear lamps	
Function	Constant current source driver
P/N	BD8371 BD8372 BD8374

Head lamps / DRL	
Function	Buck-boost DC/DC Integrated constant Current driver
P/N	BD8381 BD8382 BD8390 BD83xxx

Backlighting	
Function	Buck-boost DC/DC Integrated constant Current driver
P/N	BD8112/13 (2ch) BD8119 (4ch) BD81A04 (4ch) BD81A14 (1ch)



Excellence in Electronics
ROHM is a semiconductor and
electronic component manufacturer

Please visit us at: <http://www.rohm.com>

Thank you!