

ISDN S₀ INTERFACE TRANSFORMER

P2880

Features

- * Ultra-low profile, 7mm
- * Excellent pulse shape
- * IEC 950, EN 60950 and EN 41003 certified
- * CSA NRTL/C Certificate of Compliance
- * BAPT Certificate of Recognition
- * Vacuum encapsulated

Applications

- * Basic Rate ISDN

DESCRIPTION

P2880 is a microprofile transformer for ISDN S₀ applications requiring safety-critical isolation to international standards.

P2880 is designed specifically for S₀ ISDN interfaces complying with CCITT (ITU-T) I.430 Basic Rate requirements (2B + D at 192kbits/s).

P2880 is certified to safety standards IEC 950, EN 60950 and EN 41003 for supplementary insulation, 250V working voltage. P2880 is supported by an IEC CB Test Certificate, CSA Certificate of Compliance and BAPT Certificate.

The requirements of I.430 are easily achieved due to propriety construction which yields low leakage inductance and coupling capacitance whilst being fully compliant with international safety requirements.

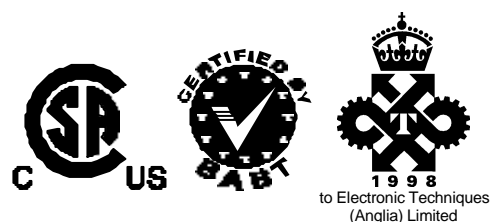

SPECIFICATION

Electrical

At T = 25°C and with pins 4 & 5 joined unless otherwise stated. The convention used in this datasheet is that 'primary' windings are on the line side and 'secondary' windings are on the IC side.

Parameter	Conditions	Min	Typ	Max	Units
Turns ratio	(1-2) : (3-5)+(4-6):	1.97	2.00	2.03	
Primary inductance	3-6				
	2kHz, 100mV	23	36	-	mH
	10kHz, 100mV	23	32	-	mH
	20kHz, 100mV	22	32	-	mH
Leakage inductance	3-6 (1 and 2 linked) 10kHz	-	4	10	μH
Shunt loss	3-6				
	2kHz 100mV	-	8	-	kΩ
	10kHz 100mV	20	-	-	kΩ
Winding DC resistance	3-6	-	3.6	-	Ω
	1-2	-	4.0	-	Ω
Parallel capacitance	3-6	-	90	-	pF
	1-2	-	20	-	pF
Interwinding capacitance	1 & 2 linked to 3, 4, 5, 6 linked	-	30	-	pF
Voltage isolation	50Hz	2.12	-	-	kVrms
	DC	3.0	-	-	kV
Operating range:					
	Functional	0	-	+70	°C
Storage		-40	-	+125	°C

SPECIFICATION

DC Imbalance

If required, P2880 will support a small degree of DC current imbalance between its primary windings, e.g. during phantom powering. DC current imbalance, however, should be limited to 1mA if P2880 is fully to comply with its specification. Fig 1 shows the effect of current imbalance on typical primary inductance.

Input/Output impedance

In the inactive, powered down or binary ONE transmission states the interface point must present a high impedance in accordance with the templates given in I.430 sections 8.5 and 8.6.

Fig 2 shows the typical primary impedance characteristic of P2880 stimulated with 100mVrms sinusoidal from 2kHz to 1MHz across pins 3 and 6 (4 & 5 linked) against the I.430 TE impedance template.

Pulse response

Fig 3 shows the pulse response test circuit.

The schottky diode ensures that the source presents a low impedance for a positive binary ZERO and a high impedance for a binary ONE.

The 62Ω resistor and the winding resistances are transformed into the primary circuit as $62/4 + 4/4 + 3.6 = 20.1\Omega$, thus satisfying the I.430 requirement for $\geq 20\Omega$ transmitter output impedance (para 8.5.1.1.(b)).

Pulse characteristics against I.430 pulse masks are given for 50Ω and 400Ω terminations and for 50Ω//400pF and 400Ω//400pF loads, figs 4-7. 400pF represents a typical EMC capacitance fitted across the primary in conjunction with a 10 metre (maximum length) connecting cord with maximum permissible capacitance of 350pF (I.430, 8.9(b)). On the 400Ω//400pF combination, the pulse trailing edge decay profile is almost completely determined by the $R_L C_L$ time constant (160ns).

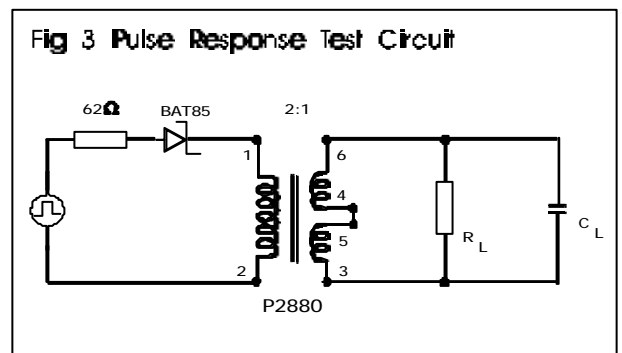
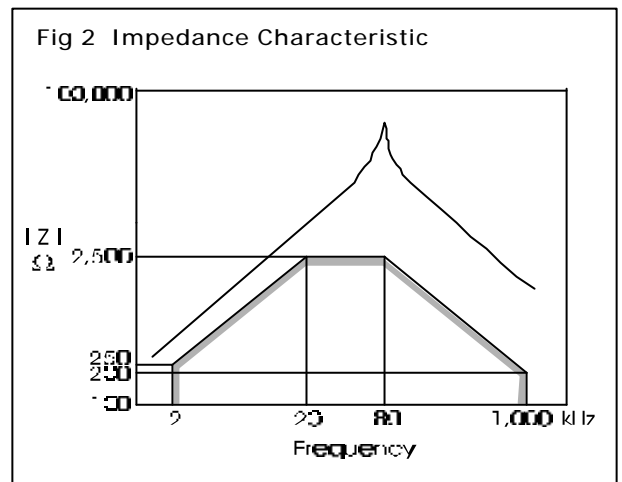
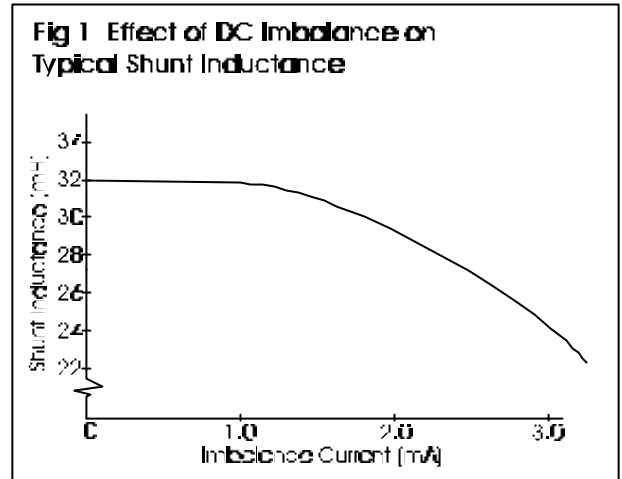
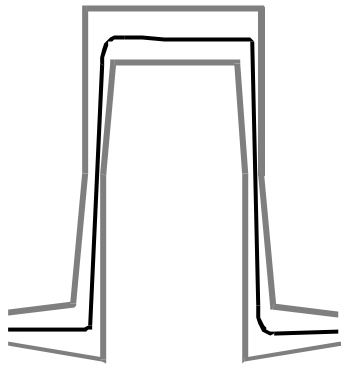
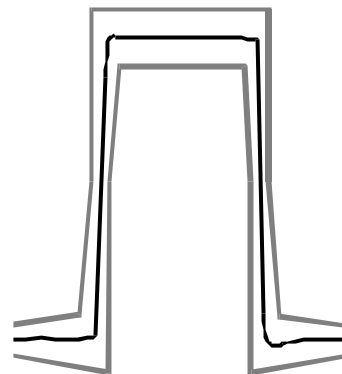
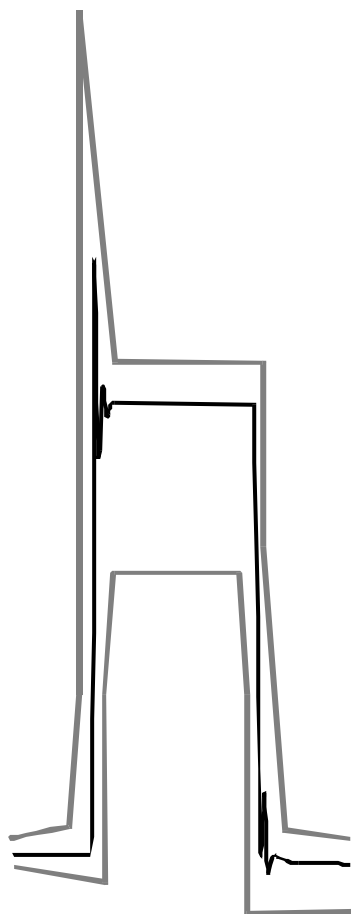
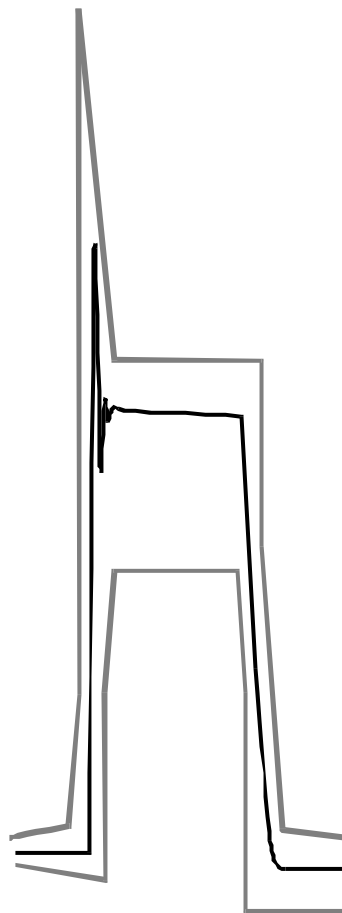

Fig 4 Pulse response $R_L = 50\Omega$, $C_L = 0$ **Fig 6** Pulse Response $R_L = 50\Omega$, $C_L = 400\text{pF}$ **Fig 5** Pulse response $R_L = 400\Omega$, $C_L = 0$ **Fig 7** Pulse Response $R_L = 400\Omega$, $C_L = 400\text{pF}$ 

APPLICATION

Applications vary depending on chipset choice and circuit requirements. A typical line interface will address the following:

1. Input/output high impedance masks which must be satisfied even in the inactive and powered-down mode.
2. Output impedance in binary ZERO state ($\geq 20\Omega$).
3. Pulse performance
4. Longitudinal conversion loss (LCL) and output signal balance (OSB).
5. EMC.
6. Overvoltage protection.

A starting point for a line-interface implementation shown in figure 8.

The current-compensated quad choke is used to achieve satisfactory LCL and OSB performance. The diodes, which must be low capacitance type, provide overvoltage protection. Each path to supply rails is through at least 2 diodes to satisfy the high impedance requirement in the presence of signals.

At the chip RX inputs, 47pF capacitors in conjunction with 10k Ω (max) series resistance provide attenuation of high frequency noise.

The 33 Ω resistors at the chip TX output set the pulse amplitude in the bus to the correct level and ensure an output impedance at the line of $>20\Omega$.

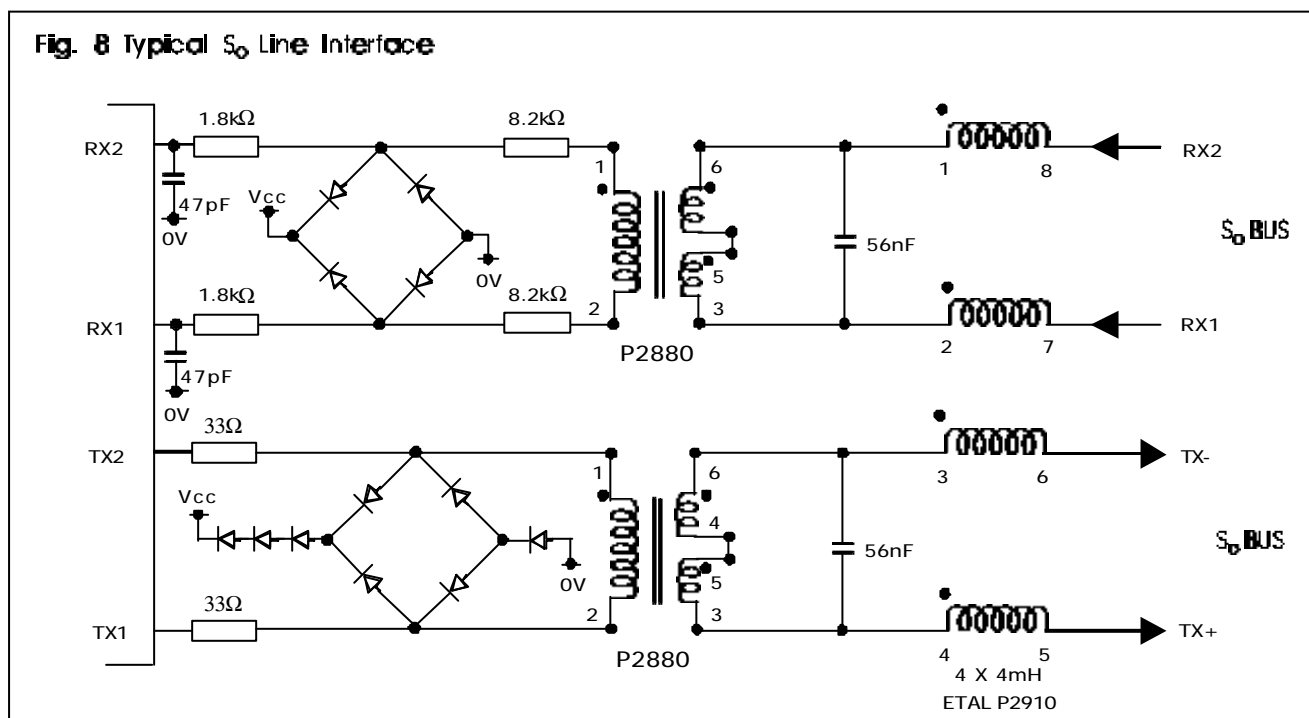

CHIPSET COMPATIBILITY

The 2:½+½ transformer ratio is suitable for a number of chipsets including:

Siemens PEB 2080
 Siemens PEB 2081
 Siemens PEB 2085
 Siemens PEB 2086
 National TP 3420
 Mitel MT 8930
 AMD AM 79C30A

For chipsets requiring 1:½+½ transformer ratio (e.g. Motorola MC145474), ETAL® P2881 is available.

For volume applications, variants can be supplied to satisfy the requirements of any other chipset.

CONSTRUCTION

Fig 9 Mechanical Specification

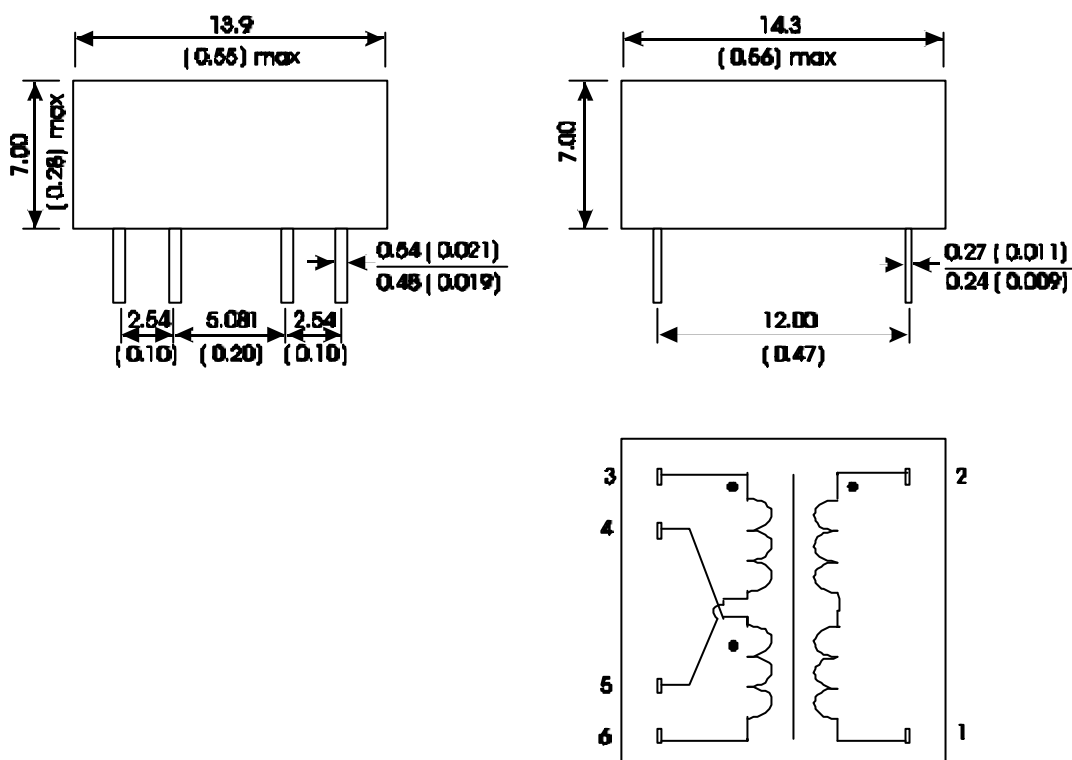

Dimensions shown are in millimetres (inches).
 Geometric centres of outline and pin grid coincide within a tolerance circle of Ø0.6mm.
 Recommended PCB hole size Ø0.8mm.
 Terminal pins electroplated Sn Pb 60/40 µm min.

SAFETY

Constructed in accordance with IEC 950:1991, EN 60950:1992 (BS 7002:1992), supplementary insulation and BS EN 41003:1997, 250Vrms working.

ABSOLUTE MAXIMUM RATINGS

(Ratings of components independent of circuit).

Short term isolation voltage (1s)	2.12kVrms 3.0kVDC
Storage temperature	-40°C to +125°C
Lead temperature, 10s	260°C

CERTIFICATION

Certified by BSI to IEC 950:1991/A4:1996 (IEC CB Test Certificate No. GB541W) sub-clauses 2.2.2, 2.9.2, 2.9.3, 2.9.4, 2.9.6, 2.9.7, 4.4, 4.4.3.2 (class V-0) and 5.3 for a maximum working voltage of 250Vrms, nominal mains supply voltage not exceeding 300Vrms and a maximum operating temperature of +70°C in Pollution Degree 3 environment, supplementary insulation.

CAN/CSA C22.2 No. 950-95/UL1950, certified by CSA, Third Edition, including revisions through to revision date March 1, 1998, based on Fourth Amendment of IEC 950, Second Edition, maximum working voltage 250Vrms, Pollution Degree 2, supplementary insulation.

CSA Certificate of Compliance 1107696 (Master Contract 1188107).
Certified by BABT to EN 60950.
BABT Certificate CR/0160.

Additionally, Profec Technologies certifies all transformers as providing voltage isolation of 2.12kVrms, 3kV DC minimum. All shipments are supported by a Certificate of Conformity to current applicable safety standards.

COPYRIGHT

ETAL and P2880 are Trade Marks of Profec Technologies Ltd.

The Trade Mark and Service Mark ETAL are registered at the UK Trade Marks Registry.

Profec Technologies Ltd. is the owner of the design right under the Copyright Designs and Patents Act 1988 and no rights or licences are hereby granted or implied to any third party.

© 1995, 2000 Profec Technologies Ltd.
Reproduction prohibited.

PROFEC
TRANSFORMING THE FUTURE



ISO 9001
FM 25326

Profec Technologies Ltd, 10 Betts Avenue, Martlesham Heath, Ipswich, IP5 3RH, England
Telephone: +44 (0) 1473 611422 Fax: +44 (0) 1473 611919
Websites: www.etal.ltd.uk www.profec.com
Email: info@etal.ltd.uk sales@profec.com