

Micrel Shortform Catalog



MICREL[®]
Innovation Through Technology[®]

February 2009

Shortform Catalog

February 2009

© 2009 Micrel, Inc.

The information furnished by Micrel, Inc., in this publication is believed to be accurate and reliable. However, no responsibility is assumed by Micrel for its use, nor any infringements of patents or other rights of third parties resulting from its use. No license is granted by implication or otherwise under any patent or patent rights of Micrel, Inc. Micrel reserves the right to change circuitry and specifications, at any time, without prior notice.

Micrel and the M design, Innovation Through Technology, LowQ, LinkMD, Precision Edge, IttyBitty, QwikRadio, RadioWire, AnyRate, AnyGate and AnyClock are registered trademarks of Micrel, Inc.

HELDO, ULDO, Trickle Mode, HyperLight Load, Teeny, and ASSET are trademarks of Micrel, Inc.

Certain QwikRadio ICs were developed under a development agreement with AIT of Orlando, Florida.

ECLinPS and ECLinPS Lite are trademarks of ON Semiconductor.

MicroLeadFrame and MLF are registered trademarks of Amkor Technology, Incorporated.

Virtex is a registered trademark of Xilinx, Incorporated.

Elan is a trademark of Advanced Micro Devices, Incorporated.

Intel and Itanium are registered trademarks of Intel Corporation.

AMD is a registered trademark of Advanced Micro Devices, Incorporated.

Contents

Corporate Profile	4
Analog Products	5
LDO Regulator Selection Guide	5
Single Outputs	5
Multiple Outputs, DUAL	7
Multiple Outputs, TRIPLE	9
LDO Controllers (N- and P-Channel), and DDR Terminators	9
HELDO™ (High Efficiency LDO)	9
Automotive (AEC-Q100 Qualified)	9
Battery Charger Selection Guide	10
Linear Battery Chargers	10
Power Management Selection Guide	10
High-Side Load Switches Selection Guide	11
Switch-Mode Voltage Regulator Selection Guide	12
Buck Regulators (Internal Switches)	12
Synchronous Buck Regulators (Internal Switches)	12
Synchronous Buck Regulators (Internal Switches + Internal Inductor)	12
Switch-Mode Voltage Regulator Selection Guide	13
Dual Synchronous Buck Regulators (Internal Switches)	13
Buck Controllers (External Switches)	13
Synchronous Buck Controllers (External Switches)	13
Boost Regulators (Internal Switches)	13
Boost Controllers (External Switches)	14
Synchronous Boost Controllers (External Switches)	14
Flyback/Forward Converter/Push-Pull Controllers for Isolated Applications (External Switches)	14
WLED Driver Selection Guide	15
Boost LED Drivers	15
Linear LED Drivers	15
High Power LED Drivers	15
General Purpose Power Distribution Switch Selection Guide	18
USB Switches and USB Switches Supporting ACPI S0/S3 State Transitions	19
USB Transceiver Selection Guide	19
PC Card/PCMCIA/CardBus Power Distribution Switch Selection Guide	20
Operational Amplifier Selection Guide	21
Comparator Selection Guide	21
MOSFET Driver Selection Guide	22
Half-Bridge Drivers	22
Low-Side Drivers	22
Voltage Monitors and Voltage/Processor Supervisors Selection Guide	24
Standard Voltage Supervisors	24
Microprocessor Supervisors with Watchdog Timers	24
Standard Voltage Supervisors for AMD Elan™ Microprocessors	24
Single and Dual Ultra-Low Voltage Supervisors	24
Voltage Monitors and Supervisors Optimized for Battery Monitoring	25
Thermal/System Management, Transistors and Arrays, Timers, References, and SCSI Terminators Selection Guides	26
2-Wire Serial Thermal Supervisors	26
Fan Management ICs	26
I/O Expanders	26

Transistors/Switches.....	26
Timers.....	26
References.....	26
Hot Swap Power Controller Selection Guide.....	27
Analog Product Highlight — MICRF302.....	28
RadioWire® and QwikRadio® RF Selection Guide.....	29
RF Remote Packet Generator.....	29
RF Transmitter (QwikRadio® and RadioWire®).....	29
RF Receivers (QwikRadio®).....	29
RF Transceivers (RadioWire®).....	29
RF Transceiver Modules.....	29
Electroluminescent Drivers Selection Guide.....	30
Display Driver Selection Guide.....	30
Latched Driver Selection Guide.....	30
Ethernet Products.....	31
Ethernet Product Highlight — KSZ8692/9692.....	31
Ethernet Selection Guide.....	32
Physical Layer Products.....	32
Embedded Controllers.....	33
Layer 2 Switch Products - Managed.....	33
System-On-a-Chip.....	34
Media Converters.....	34
Precision Edge® Products.....	35
Precision Edge® Product Family Highlight – SY56xxx.....	35
Precision Edge® Selection Guide.....	36
Clock Distribution.....	36
Clock Dividers/Generators.....	37
Crosspoint Switches.....	37
Clock Synthesis.....	38
Receivers/Buffers/Drivers.....	38
Gates and Flip-Flops.....	38
Multiplexers.....	39
Backplane and Cable Management Solutions.....	39
Phase-Locked Loop.....	40
Skew Management.....	40
Translators.....	40
MLF-8 (2mm x 2mm) Solutions.....	41
Communications Products.....	42
Communications Product Highlight — SY88993AL.....	42
Communications Selection Guide.....	43
CDRs with Integrated Clock Synthesis.....	43
Controllers.....	43
Post Amplifiers.....	44
Fractional N Synthesizers.....	44
Multiplexer/Demultiplexer.....	44
Ethernet Part Identification.....	45
High Bandwidth Part Identification.....	45
Analog Part Identification.....	46
Worldwide Representatives and Distributors.....	47

Corporate Profile

Micrel Inc., is a leading global manufacturer of IC solutions for the worldwide Analog, Ethernet and High Bandwidth markets. The Company's products include advanced mixed-signal, analog and power semiconductors; high performance communication, clock management, Ethernet switch and physical layer transceiver ICs. Company customers include leading manufacturers of enterprise, consumer, industrial, mobile, telecommunications, automotive, and computer products. Corporation headquarters and state-of-the-art wafer fabrication facilities are located in San Jose, CA with regional sales and support offices and advanced technology design centers situated throughout the Americas, Europe and Asia. In addition, the Company maintains an extensive network of distributors and reps worldwide. Web: <http://www.micrel.com>.

Founded in 1978, Micrel maintains a portfolio of world class wafer fabrication processes that enable the Company to produce new products faster than the competition. The Company uses, singularly or in combination, CMOS, Bipolar and DMOS technologies in its analog products. With the acquisition of Synergy Semiconductor in 1998, Micrel has high-speed bipolar capability in the form of ASSET™ (All Spacer Separated Element Transistor) process. This proprietary, patented bipolar technology employs a narrow deep-trench isolation technique allowing for electrical isolation between adjacent circuit elements. This means the Company can place multiple analog and digital functions on the same IC without the various functions causing interference typically found when alternate techniques are utilized.

Ethernet ICs

Micrel is a leader in Ethernet technology. The Company's Ethernet products are consistently used in Wireless, VoIP, IP-STB, Industrial, Embedded and Media Converter Ethernet applications, to name but a few. There are a wide range of field-proven, multi-port products in a variety of packages, including Physical Layer Transceivers (Phys), Embedded Controllers, Unmanaged and Managed Switches and System-on-Chip (SoC) ICs with an integrated ARM processor and fully managed 5-port switch. Micrel's comprehensive portfolio of Ethernet products operate over commercial and industrial temperature ranges, and are available in a series of environmentally friendly, lead-free packaging options.

High-Bandwidth and Communication Semiconductor Solutions

Micrel's High-Bandwidth and Communication products include PMD (Physical Media Device) ICs such as multi-rate (up to 4.25Gbps) Laser drivers, post amplifiers and optical module management controllers for all types of fiber optical module applications. It also includes physical layer ICs such as 155Mbps and multi-rate (up to 2.7Gbps) CDRs (Clock and Data Recovery), and MUX/DeMUX ICs for Access and Telecommunications applications. This growing family of devices leads the industry in design innovation and flexibility. The ICs often exceed stringent industry requirements.

Precision Edge® Products

Micrel's Precision Edge® product family includes precision frequency synthesizers, clock distribution and translation, multiplexers, crosspoint switches, and high-speed gates — all aimed at meeting the most rigorous, timing-critical applications. All Precision Edge® products are designed to provide the lowest skew and jitter IC solutions available.

Low-Dropout Voltage Regulators

Micrel has gained a reputation as a leading supplier of LDO regulators and is a major global supplier to the mobile phone and computing industries. The Company maintains a very broad portfolio of LDO regulators ranging from 80mA devices in Teeny™ SC-70-5 packages to 7.5A power devices and LDO controllers for even higher current applications.

Radio Frequency Products

Micrel's RF offering consists of two product groups: QwikRadio® receivers and transmitters for actuation devices such as remote controls and remote keyless entry; and RadioWire® transceivers for connectivity applications such as wire replacement in industrial control and security systems.

Universal Serial Bus and PCMCIA

As a recognized leader of USB and PC Card power distribution solutions, Micrel's extensive selection of ICs are consistently used by many of the leading PC and peripheral OEMs.

Hot Swap Controllers

Micrel's hot swap power controllers support the industry requirement for high availability (24/7/365) operation in servers, telecom and datacom equipment, and enterprise storage networks. These products allow customers to upgrade or replace system boards without having to power down the entire system. Offering products for primary- and

secondary-side applications, Micrel's family of hot swap power controllers offers customers a wide range of product choices uniquely suited to these applications. This product portfolio includes the award-winning MIC2590B, the industry's most integrated dual-slot hot swap power controller for PCI and CompactPCI applications. Leveraging Micrel's expertise in power control and distribution, the MIC2590B was designed to support Intel's Itanium® 64-bit server platforms. To address the next generation, dual-slot power controllers are in development. For primary-side applications, the Company continues to add innovative products to the high-voltage hot swap product portfolio, addressing power control applications for the telecommunications, data communications, and data storage equipment markets.

MOSFET Drivers

Micrel offers a broad range of MOSFET drivers, ranging from IttyBitty® devices in SOT-23 packaging to 12A high-power devices. "New" device families offer thermally enhanced exposed pad SOIC, MSOP and space saving efficient MLF® 2mm x 2mm, 3mm x 3mm and 4mm x 4mm package options.

Switch-Mode Power Supply Products

Micrel has a rapidly expanding portfolio of switching regulator products serving the mobile device, portable computer, telecommunications and industrial markets. All products combine Micrel's advanced processes with the Company's strong design expertise to produce best-in-class products. These products address step-up, step-down and multi-output systems, all offering designers speed and efficiency advantages.

System/Thermal Management Products

Thermal management is an increasingly critical function in today's portable and high performance systems. Micrel's proprietary technology enables more functionality in smaller packages and superior, real-world accuracy in temperature measurement via embedded thermal diodes. Thermal diodes are increasingly used to monitor the die temperature of high-performance integrated circuits such as Intel® and AMD® microprocessors, Xilinx Virtex®, FPGAs, and ASICs. Micrel's family of products include the world's first and only IttyBitty® SOT-23 thermal diode supervisor IC and the smallest three-zone thermal supervisor. All together, Micrel offers a complete family of one, two, and three-zone thermal supervisor ICs as well as both analog and digital fan controllers.

Operational Amplifiers and Comparators

The Company has a broad range of high and low voltage op amps and comparators. These ICs range from general purpose to high speed devices. Of particular note is the MIC86x family of ICs which are, by far, the lowest power consumption op amps of their type on the market. The advanced features of these products make them ideally suited for all forms of battery-powered equipment.

Other Product Lines

- Charge pumps
- Voltage references
- Voltage/processor supervisors
- Miniature MOSFETs
- Serial and parallel-input latched drivers
- Display drivers
- Latch drivers
- Custom and semi-custom products

Big Technology, Small Package Innovation

In response to increasing demands for smaller and smaller footprint solutions, Micrel leads the industry in packaging innovation with IC packaging options, including MLF® technology, down to 1.2mm x 1.6mm and smaller.

Quality Assurance

Micrel first achieved ISO 9001 registration on March 31, 1997 and on December of 2004, the Company's wafer fabrication facility was certified to ISO14001:1996, the International Environmental Management System Standard. The goal of the environmental management system is to ensure regulatory compliance and to reduce environmental impact through waste reduction and recycling. Micrel is committed to delivering products and services that meet or exceed our customers' expectations — error free, on-schedule, and at a competitive price. Micrel maintains a culture of continuous improvement that runs through all disciplines in the company and includes the activities of its suppliers.

Commitment to Customer Satisfaction

Micrel remains committed to contributing to its customers' success. Internal processes have been developed with flexibility in mind, so the Company can quickly react to changing requirements. Micrel's outstanding sales, customer service and technical support organizations are set up to address customer needs and requirements.

LDO Regulator Selection Guide

Micrel Advantange

- Industry's broadest LDO porfolio
- Lowest input voltages
- Best transient performance
- Lowest quiescent current and dropout
- High PSRR, Low noise
- Small and efficient packaging

Single Outputs

Device	I _{OUT}	V _{IN}	V _{OUT}	I _{GND} (Typ.)	V _{DROPOUT} (Typ.)	Package	Comments	µCap
MIC5231	10mA	3.5V to 12V	2.75, 3.0, 3.3, 5.0	650nA	150mV	SOT-23		Yes
MIC5232	10mA	2.7V to 7.0V	1.2, 2.8, 3.3	1.8µA	100mV	TSOT-23-5, MLF [®] (2x2mm)	Ultra Low I _Q µCap 10mA LDO with Reverse Current Protection	Yes
MAQ5280 <i>New!</i>	25mA	4.5V to 120V	Adj.	31µA	1.1V	eSOIC-8	Wide Input Voltage Range	
MIC5203	80mA	2.5V to 16V	2.6, 2.8, 3.0, 3.3, 3.6, 3.8, 4.0, 4.5, 5.0	180µA	300mV	SOT-23		Yes
MIC5213	80mA	2.5V to 16V	2.5, 2.6, 2.7, 2.8, 3.0, 3.3, 3.6, 5.0	180µA	300mV	SC70		Yes
LP2950	100mA	2V to 30V	5.0, 5.0(0.5%)	100µA	380mV		2nd Source to Natl.	
LP2951	100mA	2V to 30V	5.0(0.5%), 5.0(1%), Adj.	100µA	380mV	SOIC, PDIP	2nd Source to Natl.	
MIC5200	100mA	2.5V to 26V	3.0, 3.3, 4.8, 5.0	130µA	230mV	MSOP, SOIC, SOT-223	Load Dump Protection.	
MIC5233	100mA	2.3V to 36V	1.8, 2.5, 3.0, 3.3, 5.0, Adj.	18µA	270mV	SOT-23	Reverse Battery Protection.	Yes
MIC5253	100mA	2.7V to 6V	1.5, 1.8, 1.85, 2.5, 2.6, 2.7, 2.8, 2.85, 2.9, 3.0, 3.1, 3.2, 3.3	100µA	165mV	SC70		Yes
MIC5270	100mA	-2V to -16V	-3.0, -4.1, -5.0, Adj.	35µA	480mV	SOT-23	Negative µCap LDO.	Yes
MIC5271	100mA	-3.3V to -16V	-3.0, -5.0, Adj.	35µA	480mV	SOT-23	Negative µCap LDO.	Yes
MIC2950	150mA	2V to 30V	5.0, 5.0(0.5%)	120µA	300mV		High V _{IN} , Load Dump Protection.	
MIC2951	150mA	2V to 30V	3.3, 4.85, 5.0(0.5%), 5.0(1%) Adj	120µA	300mV	MSOP, SOIC, PDIP	High V _{IN} , Load Dump Protection.	
MIC5205	150mA	2.5V to 16V	2.5, 2.7, 2.8, 2.85, 2.9, 3.0, 3.1, 3.2, 3.3, 3.6, 3.8, 4.0, 5.0, Adj.	80µA	165mV	SOT-23	Low Noise LDO.	
MIC5206	150mA	2.5V to 16V	2.5, 2.7, 3.0, 3.2, 3.3, 3.6, 3.8, 4.0, 5.0, Adj	80µA	165mV	MSOP, SOT-23	Low Noise LDO w/Error Flag.	
MIC5235	150mA	2.3V to 24V	1.5, 1.8, 2.5, 2.7, 3.0, 3.3, 5.0, Adj.	18µA	310mV	SOT-23	Zero Shutdown Current, Reverse Battery Protection.	Yes
MIC5236	150mA	2.3V to 30V	2.5, 3.0, 3.3, 5.0, Adj.	20µA	350mV	P-MSOP, P-SOIC	Load Dump Protected µCap LDO.	Yes
MIC5238	150mA	1.5V to 6V	1.0, 1.1, 1.2, 1.3	23µA	310mV	T/SOT	Low Voltage, Dual Supply µCap.	Yes
MIC5247	150mA	2.7V to 6V	1.5, 1.6, 1.8, 1.85, 2.0, 2.4	85µA	150mV	MLF [®] (2x2mm), T/SOT		Yes
MIC5248	150mA	2.7V to 6V	1.2	85µA	n/a	SOT-23	1.2V LDO with Power Good.	Yes
MIC5252	150mA	2.7V to 6V	1.8, 2.5, 2.8, 2.85, 3.0, 4.75	90µA	135mV	MLF [®] (2x2mm), SOT-23	Low Noise LDO.	Yes
MIC5254	150mA	2.7V to 6V	3.3/2.5	117µA	135mV	MSOP	w/Error Flags.	Yes
MIC5255	150mA	2.7V to 6V	2.5, 2.6, 2.7, 2.75, 2.8, 2.85, 2.9, 3.0, 3.1, 3.2, 3.3, 3.5	90µA	135mV	MLF [®] (2x2mm), TSOT	Low Noise LDO.	Yes
MIC5256	150mA	2.7V to 6V	2.5, 2.6, 2.7, 2.9, 2.8, 2.85, 3.0, 3.1, 3.3	90µA	135mV	T/SOT	Low Noise with Error Flag.	Yes
MIC5258	150mA	2.7V to 6V	1.2	85µA	n/a	SOT-23	1.2V LDO with Power Good.	Yes
MIC5265	150mA	2.7V to 5.5V	1.5, 1.8, 1.85, 2.5, 2.6, 2.7, 2.8, 2.85, 2.9, 3.0, 3.1, 3.2, 3.3	75µA	210mV	TSOT	General Purpose LDO.	Yes
MIC5268	150mA	2.7V to 6V	1.2	85µA	n/a	SOT-23		Yes
MIC5301	150mA	2.3V to 5.5V	1.3, 1.5, 1.8, 2.1, 2.5, 2.85, 2.8, 2.9, 3.0, 3.3, 4.6, Adj.	85µA	40mV	Thin MLF [®] , TSOT23-5 MLF [®] (1.6x1.6mm)		Yes
MIC5302	150mA	2.3V to 5.5V	1.3, 1.5, 1.8, 2.1, 2.5, 2.85, 2.8, 2.9, 3.0, 3.3, 4.6, Adj.	85µA	50mV	Thin MLF [®] , (1.2x1.6mm)	Ultra-small	Yes
MIC5304 <i>New!</i>	150mA		3.15/1.85	24µA	85mV	Thin MLF [®] , (1.6x1.6mm)	Single 150mA Micro Power ULDO™ Yes with Voltage Select Pin	Yes
MIC5305	150mA	2.25V to 5.5V	1.5, 1.8, 2.5, 2.6, 2.7, 2.8, 2.85, 2.9, 3.0, 3.3, 4.75, Adj.	90µA	60mV	MLF [®] (2x2mm), TSOT, Thin MLF [®]	High PSRR Low Noise ULDO™.	Yes
MIC5306	150mA	2.25V to 5.5V	1.5, 1.8, 2.7, 2.8, 3.0, 3.1, 3.3	16µA	120mV	TSOT, MLF [®] (2x2mm)	Low I _Q , 150mA ULDO™.	Yes
MIC5308	150mA	1.6V to 5.5V	1.0, 1.2, 1.3, 1.5, Adj.	23µA	50mV	TSOT-23-6, MLF [®] (1.6x1.6mm)	Low V _{IN} /V _{OUT} with Ultra-low I _Q .	
MIC5365 <i>New!</i>	150mA		1.0, 1.2, 1.3, 1.5, 1.8, 2.0, 2.4, 2.5, 2.6, 2.8, 3.0, 3.3	32µA	180mV	Thin MLF [®] (1x1mm), SC-70	Ultra-small Single 150mA ULDO™	Yes
MIC5366 <i>New!</i>	150mA		1.0, 1.2, 1.3, 1.5, 1.8, 2.0, 2.4, 2.5, 2.6, 2.8, 3.0, 3.3	32µA	180mV	Thin MLF [®] (1x1mm), SC-70	Ultra-small Single 150mA ULDO™ with Auto Discharge	Yes

LDO Regulator Selection Guide

Single Outputs (continued)

Device	I _{OUT}	V _{IN}	V _{OUT}	I _{GND} (Typ.)	V _{DROPOUT} (Typ.)	Package	Comments	µCaP
MIC5207	180mA	2.5V to 16V	1.8, 2.5, 2.8, 2.9, 3.0, 3.1, 3.2, 3.3, 3.6, 3.8, 4.0, 5.0, Adj.	80µA	165mV	T/SOT	Low Noise LDO.	
MIC5201	200mA	2.5V to 26V	3.0, 3.3, 4.8, 5.0, Adj.	130µA	270mV	SOIC, SOT-223	Load Dump Protection.	
MIC5309	300mA	1.7V to 5.5V	1.0, 1.2, 1.3, 1.5, Adj.	23µA	100mV	TSOT-23-6, MLF® (1.6x1.6mm)	Low V _{IN} /V _{OUT} with Ultra-low I _Q .	
MIC2954	250mA	2V to 30V	5.0, 5.0 (0.5%) Adj.	140µA	375mV	SOIC, SOT-223, TO-220	Load Dump Protection.	
MIC5303	300mA	2.3V to 5.5V	1.3, 1.5, 1.8, 2.1, 2.5, 2.85, 2.8, 2.9, 3.0, 3.3, 4.6, Adj.	85µA	100mV	Thin MLF® (1.2x1.6mm)	High I _{OUT} , ultra-small.	Yes
MIC5307	300mA	2.4V to 5.5V	2.8, 3.0, Adj.	20µA	120mV	MLF® (1.6x1.6mm) TSOT-23	Ultra-low I _Q , 300mA ULDO™.	Yes
MIC5318	300mA	2.3V to 6.0V	2.8, 2.85, Adj.	85µA	100mV	Thin MLF® (1.6x1.6mm) TSOT-23	High V _{IN} .	Yes
MIC5249	300mA	2.7V to 6V	1.8, 2.5, 2.6, 2.8, 2.85, 3.0, 3.3	90µA	400mV	MSOP	LDO w/POR.	Yes
MIC5259	300mA	2.7V to 6V	1.5, 1.8, 2.5, 2.8, 2.85, 3.0, 3.3	90µA	300mV	MLF® (2x2mm), TSOT	High PSRR Low Noise LDO.	Yes
MIC29201	400mA	4.3V to 26V	3.3, 4.85, 5.0, 12	140µA	450mV	SOIC, TO-220, TO-263	Load Dump Protection.	
MIC29202	400mA	4.3V to 26V	Adj.	140µA	450mV	TO-220, TO-263	Load Dump Protection.	
MIC29204	400mA	4.3V to 26V	5.0, Adj.	140µA	450mV	SOIC, PDIP	Load Dump Protection.	
MIC2920A	400mA	4.3V to 26V	3.3, 4.8, 5.0, 12	140µA	450mV	SOT-223, TO-220	Load Dump Protection.	
MIC5325	400mA	1.7V to 5.5V	1.2, 1.5, 1.8, Adj.	35µA	110mV	Thin MLF® (2x2mm)	Single 400mA ULDO™. Pin Compatible to LTC3025.	Yes
MIC5209	500mA	2.5V to 16V	1.8, 2.5, 3.0, 3.3, 3.6, 4.2, 5.0, Adj.	80µA	300mV	P-SOIC, SOT-223, TO-263	Low Noise LDO.	
MIC5216	500mA	2.5V to 12V	2.5, 3.3, 3.6, 5.0	80µA	300mV	SOT-23, P-MSOP	Low Noise LDO w/Error Flag.	
MIC5219	500mA	2.5V to 12V	2.5, 2.6, 2.7, 2.8, 2.85, 2.9, 3.0, 3.1, 3.3, 3.6, 5.0, Adj.	80µA	300mV	SOT-23, P-MSOP, MLF® (2x2mm)	Low Noise LDO.	
MIC5237	500mA	2.5V to 16V	2.5, 3.3, 5.0	80µA	300mV	TO-220 TO-263	>3% O/P Voltage Accuracy.	
MIC5239	500mA	2.3V to 30V	1.5, 1.8, 2.5, 3.0, 3.3, 5.0, Adj.	23µA	350mV	P-MSOP, P-SOIC, SOT-223	Reverse Battery Protection.	Yes
MIC5319	500mA	2.5V to 5.5V	1.375, 1.8, 1.85, 2.5, 2.6, 2.7, 2.8, 2.85, 2.9, 3.0, 3.3, 5.0, Adj.	90µA	200mV	MLF® (2x2mm), TSOT	ULDO™ High PSRR.	Yes
MIC29371	750mA	4.3V to 26V	3.3, 5.0, 12	160µA	370mV	TO-220, TO-263	Load Dump Protection.	
MIC29372	750mA	4.3V to 26V	Adj.	160µA	370mV	TO-220, TO-263	Load Dump Protection.	
MIC2937A	750mA	4.3V to 26V	3.3, 5.0, 12	160µA	370mV	TO-220, TO-263	Load Dump Protection.	
MIC3775	750mA	2.25V to 6V	1.5, 1.65, 1.8, 2.5, 3.0, 3.3, Adj.	400µA	300mV	P-MSOP	Wide V _{IN} Range.	Yes
MIC3975	750mA	2.25V to 16V	1.8, 2.5, 3.0, 3.3, 5.0, Adj.	400µA	300mV	P-MSOP	Wide V _{IN} Range.	Yes
MIC37100	1A	2.25V to 6V	1.5, 1.65, 1.8, 2.5, 3.3	400µA	280mV	SOT-223		Yes
MIC37101	1A	2.25V to 6V	1.5, 1.65, 1.8, 2.1, 2.5, 3.3	400µA	280mV	P-SOIC	w/EN and Error Flag.	Yes
MIC37102	1A	2.25V to 6V	Adj.	400µA	280mV	P-SOIC, SPAK		Yes
MIC39100	1A	2.25V to 16V	1.8, 2.5, 3.3, 5.0	400µA	410mV	SOT-223, TO-220, TO-263	Ultra-Low Dropout.	
MIC39101	1A	2.25V to 16V	1.8, 2.5, 3.3, 5.0	400µA	410mV	P-SOIC	Ultra-Low Dropout.	
MIC39102	1A	2.25V to 16V	Adj.	400µA	410mV	P-SOIC	Ultra-Low Dropout.	
MIC47100	1A	1.0V to 3.6V	0.8, 1.0, 1.2, Adj.	350µA	80mV	MLF® (2x2mm), eMSOP-8		
MIC69101	<i>New!</i> 1A	1.65V to 5.5V	1.8	12mA	500mV	MLF® (3x3mm), P-MSOP-8	Ultra-small 1A LDO. Single Supply Operation.	
MIC69103	<i>New!</i> 1A	1.65V to 5.5V	Adj.	12mA	500mV	MLF® (3x3mm), P-MSOP-8	Ultra-small 1A LDO. Single Supply Operation.	
MIC2940A	1.25A	4.3V to 26V	3.3, 5.0, 12	240µA	400mV	TO-220, TO-263	Load Dump Protection.	
MIC2941A	1.25A	4.3V to 26V	Adj.	240µA	400mV	TO-220, TO-263	Load Dump Protection.	
MIC2915x	1.5A	2.25V to 26V	3.3, 5.0, 12, Adj.	225µA	350mV	TO-220, TO-263	Load Dump Protection.	
MIC37139	1.5A	2.25V to 6V	1.8	17mA	350mV	SOT-223		Yes
MIC37150	1.5A	2.25 to 6V	1.5, 1.65, 1.8, 2.5, 3.3	17mA	325mV	SPAK	Fixed Voltage in 3-pin Package.	Yes
MIC37151	1.5A	2.25V to 6V	1.5, 1.65, 1.8, 2.5, 3.3	17mA	325mV	SPAK, eSOIC	w/EN and Error Flag.	Yes
MIC37152	1.5A	2.25V to 6V	Adj.	17mA	325mV	SPAK		Yes
MIC37153	1.5A	2.25V to 6V	Adj.	17mA	325mV	eSOIC	w/EN and Error Flag.	Yes
MIC39150	1.5A	2.25V to 16V	1.65, 1.8, 2.5	300µA	375mV	TO-220, TO-263	Ultra-Low Dropout.	
MIC39151	1.5A	2.25V to 16V	1.65, 1.8, 2.5	300µA	375mV	TO-220, TO-263	Ultra-Low Dropout w/EN.	

LDO Regulator Selection Guide

Single Outputs (continued)

Device	I _{OUT}	V _{IN}	V _{OUT}	I _{GND} (Typ.)	V _{DROPOUT} (Typ.)	Package	Comments	µCap
MIC49150	1.5A	1.4V to 6V	0.9, 1.2, 1.5, 1.8, Adj.	15mA	280mV	P-MSOP, S-PAK	Dual Supply µCap LDO.	Yes
MIC59150 <i>New!</i>	1.5A	1.0V to 3.3V	Adj.			eSOIC-8	Dual Supply, Low V _{IN} LDO.	Yes
MIC69151 <i>New!</i>	1.5A	1.65V to 5.5V	1.8	22mA	500mV	MLF [®] (3mm x 3mm), eSOIC-8	Single Supply Operation.	
MIC69153 <i>New!</i>	1.5A	1.65V to 5.5V	Adj.	22mA	500mV	MLF [®] (3mm x 3mm), eSOIC-8	Single Supply Operation.	
MIC49200	2A	1.4V to 6V	1.0, 1.8, Adj.	15mA	400mV	SPAK, TO-263	Dual Supply µCap LDO.	Yes
MIC68200	2A	1.65V to 5.5V	1.2, 1.5, 1.8, 2.5, 3.3, Adj.	7mA	140mV	MLF [®] (3mm x 3mm)	Tracking & Ramp Control.	Yes
MIC37252	2.5A	3.0V to 6V	Adj.	40mA	550mV	SPAK, TO-263	Low Voltage µCap LDO.	
MIC37253	2.5A	3.0V to 6V	Adj.	40mA	600mV	eSOIC	w/EN and Error Flag.	
MIC2930x	3A	2.25V to 26V	3.3, 5.0, 12, Adj.	225µA	370mV	TO-220, TO-263	Load Dump Protection.	
MIC29310/2	3A	2.3V to 16V	3.3, 5.0, Adj.	400µA	600mV	TO-220, TO-263		
MIC29311	3A	2.3V to 16V	5.1	400µA	600mV	TO-220	USB LDO.	
MIC37301	3A	2.25V to 6V	1.5, 1.65, 1.8, 2.5, 3.3	27mA	300mV	SPAK		Yes
MIC37302	3A	2.25V to 6V	Adj.	27mA	300mV	SPAK, TO-263		Yes
MIC37303	3A	2.25V to 6V	Adj.	27mA	325mV	eSOIC	w/EN and Error Flag.	Yes
MIC39300	3A	2.25V to 16V	1.8, 2.5	5mA	300mV	TO-220, TO-263	Ultra-Low Dropout.	
MIC39301	3A	2.25V to 16V	1.8, 2.5	5mA	350mV	TO-220, TO-263	Ultra-Low Dropout w/EN.	
MIC49300	3A	1.4V to 6V	0.9, 1.2, 1.5, 1.8, Adj.	25mA	280mV	SPAK	Dual Supply µCap LDO.	Yes
MIC59300 <i>New!</i>	3A	1.0V to 3.8V	Adj., 1.2V	0.1µA	205mV	TO-263-5, eSOIC-8	Dual Supply, Low V _{IN} LDO.	Yes
MIC69301	3A	1.65V to 5.5V	1.0, 1.2, 1.8	40mA	275mV	SPAK, eSOIC	Low Voltage Single Input Supply.	Yes
MIC69302	3A	1.65V to 5.5V	Adj.	40mA	275mV	SPAK, eSOIC	Low Voltage Single Input Supply.	Yes
MIC68400	4A	1.65V to 5.5V	0.8, 1.0, 1.2, 1.5, 1.8, 2.5, Adj.	18mA	300mV	TSSOP, MLF [®] (4mm x 4mm)	Tracking and Ramp Control.	Yes
MIC2950x	5A	2.25V to 26V	3.3, 5.0, Adj.	225µA	370mV	TO-220, TO-263	Load Dump Protection.	
MIC29510/2	5A	2.3V to 16V	3.3, 5.0, Adj.	500µA	700mV	TO-220		
MIC37501	5A	2.3V to 6V	1.5, 1.65, 1.8, 2.5, 3.3	57mA	330mV	SPAK		Yes
MIC37502	5A	2.3V to 6V	Adj.	57mA	330mV	SPAK, TO-263		Yes
MIC39500	5A	2.25V to 16V	1.8, 2.5	70mA	350mV	TO-220, TO-263	Ultra-Low Dropout.	
MIC39501	5A	2.25V to 16V	1.8, 2.5	70mA	350mV	TO-220, TO-263	Ultra-Low Dropout w/EN.	
MIC49500	5A	1.4V to 6V	0.9, 1.2, Adj.	55mA	290mV	SPAK, TO-263	Dual Supply µCap LDO.	Yes
MIC69502	5A	1.65V to 5.5V	Adj.	54mA	250mV	SPAK	Low Voltage Single Input Supply.	Yes
MIC2971x	7.5A	2.3V to 16V	3.3, 5.0, Adj.	1mA	700mV	TO-220		
MIC29750	7.5A	2.5V to 26V	3.3, 5.0	35mA	425mV	TO-247	Load Dump Protection.	
MIC29751	7.5A	2.5V to 26V	3.3, 5.0	35mA	425mV	TO-247	Load Dump Protection.	
MIC29752	7.5A	2.5V to 26V	Adj.	35mA	425mV	TO-247	Load Dump Protection.	

Multiple Outputs, DUAL

Device	I _{OUT}	V _{IN}	V _{OUT}	I _{GND} (Typ.)	V _{DROPOUT} (Typ.)	Package	Comments	µCap
MIC5208	50/50mA	2.5V to 16V	3.3, 3.8, 4.0	180µA	250mV	MSOP	±3%	Yes
MIC5211	50/50mA	2.5V to 16V	1.8, 1.8/2.5, 1.8/3.3, 2.5, 2.5/3.3, 2.7, 2.8, 3.0, 3.3, 3.3/5.0, 3.6, 5.0,					
MIC5202	100/100mA	2.5V to 26V	3.0, 3.3, 4.8, 5.0	170µA	225mV	SOIC	±1%	
MIC5210	150/150mA	2.5V to 16V	2.7, 2.8, 3.0, 3.3, 3.6, 4.0, 5.0	80µA	165mV	MSOP	Low Noise LDO.	
MIC5310	150/150mA	2.3V to 5.5V	1.8/1.5, 1.8/1.8, 1.8/1.6, 2.5/1.8, 2.5/2.5, 2.6/1.85, 2.6/1.8 2.7/2.7, 2.8/1.5, 2.8/1.8, 2.8/2.6, 2.8/2.8, 2.85/1.85, 2.85/2.6, 2.85/2.85, 2.9/1.5, 2.9/1.8, 2.9/2.9, 3.0/1.8, 3.0/2.5 3.0/2.6, 3.0/2.8, 3.0/2.85, 3.0/3.0, 3.3/1.5, 3.3/1.8, 3.3/2.5 3.3/2.6, 3.3/2.8, 3.3/2.85, 3.3/2.9, 3.3/3.0, 3.3/3.2, 3.3/3.3,	75µA	35mV	MLF [®] (2mm x 2mm)	Tiny ULDO™ • Dual Enable • High PSRR	Yes
MIC5320	150/150mA	2.3V to 5.5V	1.8/1.5, 1.8/1.8, 1.8/1.6, 2.4/1.5, 2.5/1.8, 2.5/2.5, 2.6/1.85, 2.6/1.8, 2.7/2.7, 2.8/1.5, 2.8/1.8, 2.8/2.6, 2.8/2.8, 2.85/1.85, 2.85/2.6, 2.85/2.85, 2.9/1.5, 2.9/1.8, 2.9/2.9, 3.0/1.8, 3.0/2.5, 3.0/2.6, 3.0/2.8, 3.0/2.85, 3.0/3.0, 3.3/1.5, 3.3/1.8, 3.3/2.5, 3.3/2.6, 3.3/2.8, 3.3/2.85, 3.3/2.9, 3.3/3.0, 3.3/3.2, 3.3/3.3, 4.6/2.8,	75µA	35mV	MLF [®] (1.6mm x 1.6mm) TSOT-06	Tiny ULDO™ • Dual Enable	Yes

LDO Regulator Selection Guide

Multiple Outputs, DUAL (continued)

Device	I _{OUT}	V _{IN}	V _{OUT}	I _{GND} (Typ.)	V _{DROPOUT} (Typ.)	Package	Comments	µCaP
MIC5321	150/150mA	2.3V to 5.5V	1.8/1.5, 1.8/1.8, 1.8/1.6, 2.4/1.5, 2.5/1.8, 2.5/2.5, 2.6/1.85, 2.6/1.8, 2.7/2.7, 2.8/1.5, 2.8/1.8, 2.8/2.6, 2.8/2.8, 2.85/1.85, 2.85/2.6, 2.85/2.85, 2.9/1.5, 2.9/1.8, 2.9/2.9, 3.0/1.8, 3.0/2.5, 3.0/2.6, 3.0/2.8, 3.0/2.85, 3.0/3.0, 3.3/1.5, 3.3/1.8, 3.3/2.5, 3.3/2.6, 3.3/2.8, 3.3/2.85, 3.3/2.9, 3.3/3.0, 3.3/3.2, 3.3/3.3, 4.6/2.8,	75µA	35mV	MLF [®] (1.6mm x 1.6mm) TSOT-6	Tiny ULDO™ • High PSRR • Common Enable • Bypass Pin	Yes
MIC5322	150/150mA	2.5V to 5.5V	2.8/1.5, 2.8/1.8, 2.85/2.85, 3.0/2.8, 3.0/2.85, 3.0/3.0	150µA	35mV	Thin MLF [®] (1.6mm x 1.6mm)	Tiny ULDO™ • High PSRR • Common Active Low Enable • Bypass	Yes
MIC5370	<i>New!</i> 150/150mA		1.8/1.5, 1.8/1.8, 1.8/1.6, 2.4/1.5, 2.5/1.8, 2.5/2.5, 2.6/1.85, 2.85/1.85, 2.85/2.6, 2.85/2.85, 2.9/1.5, 2.9/1.8, 2.9/2.9, 3.0/1.8, 3.0/2.5, 3.0/2.6, 3.0/2.8, 3.0/2.85, 3.0/3.0, 3.3/1.5, 3.3/1.8, 3.3/2.5, 3.3/2.6, 3.3/2.8, 3.3/2.85, 3.3/2.9, 3.3/3.0, 3.3/3.2, 3.3/3.3, 4.6/2.8,	49µA	190mV	Thin MLF [®] (1.6mm x 1.6mm)	General Purpose Dual 150mA LDO.	Yes
MIC5371	<i>New!</i> 150/150mA		1.8/1.5, 1.8/1.8, 1.8/1.6, 2.4/1.5, 2.5/1.8, 2.5/2.5, 2.6/1.85, 2.85/1.85, 2.85/2.6, 2.85/2.85, 2.9/1.5, 2.9/1.8, 2.9/2.9, 3.0/1.8, 3.0/2.5, 3.0/2.6, 3.0/2.8, 3.0/2.85, 3.0/3.0, 3.3/1.5, 3.3/1.8, 3.3/2.5, 3.3/2.6, 3.3/2.8, 3.3/2.85, 3.3/2.9, 3.3/3.0, 3.3/3.2, 3.3/3.3, 4.6/2.8,	49µA	190mV	Thin MLF [®] (1.6mm x 1.6mm)	General Purpose Dual 150mA LDO with Auto Discharge.	Yes
MIC5264	150/150mA	2.7V to 5.5V	2.5/1.8, 2.6/1.8, 2.6/2.6, 2.8/1.5, 2.8/1.8, 2.8/2.5, 2.8/2.6, 2.8/2.8, 2.85/1.52, 85/1.8, 2.85/2.85, 2.9/2.6, 3.0/1.8, 3.0/2.5, 3.0/2.8, 3.0/3.0, 3.3/3.3	75µA	210mV	MLF [®] (2.5mm x 2.5mm)	µCap LDO Regulator.	Yes
MIC2210	150/300mA	2.25V to 5.5V	1.5/2.8, 1.8/3.3, 2.8/1.6, 2.8/3.0, 3.0/3.3, 3.3/3.3	48µA	120mV	MLF [®] (3mm x 3mm)	LDO w/Driver & Error Flag.	
MIC2211	150/300mA	2.25V to 5.5V	Adj/Adj, 1.5/1.8, 1.5/2.8, 1.5/2.85, 1.5/2.9, 1.5/3.1, 1.6/2.8, 1.6/2.9, 1.6/3.3, 1.8/2.5, 1.8/2.6, 1.8/2.8, 1.8/2.9, 1.8/3.0, 1.8/3.3, 1.9/2.8, 2.0/3.0, 2.5/1.8, 2.5/1.9, 2.5/2.8, 2.5/3.0, 2.5/3.3, 2.6/1.8, 2.6/2.85, 2.6/3.0, 2.7/1.8, 2.7/3.0, 2.8/1.5, 2.8/1.6, 2.8/1.8, 2.8/2.5, 2.8/2.8, 2.8/3.0, 2.8/3.3, 2.85/2.85, 2.85/3.3, 2.9/1.5, 2.9/2.9, 3.0/1.6, 3.0/2.7, 3.0/2.8, 3.0/2.85, 3.0/3.0, 3.0/3.3, 3.3/1.8, 3.3/2.8, 3.3/3.3, 3.6/3.6	48µA	120mV	MLF [®] (3mm x 3mm)	LDO.	Yes
MIC2212	150/300mA	2.25V to 5.5V	1.6/2.8, 1.6/3.3, 1.8/2.6, 1.8/2.7, 1.8/2.8, 1.8/3.0, 1.8/3.3, 1.85/2.85, 1.85/2.9, 2.5/3.3, 2.6/2.8, 2.6/2.85, 2.7/2.8, 2.7/2.9, 2.7/3.0, 2.8/2.6, 2.8/2.8, 2.8/3.0, 2.85/2.85, 3.0/2.8, 3.0/2.85, 3.0/3.0, 3.0/3.3, 3.3/1.8, 3.3/2.5, 3.3/2.8	48µA	120mV	MLF [®] (3mm x 3mm)	LDO w/POR.	Yes
MIC2213	150/300mA	2.25V to 5.5V	1.8/2.85, 1.8/3.3, 2.5/3.3, Adj/Adj.	48µA	120mV	MLF [®] (3mm x 3mm)	Sequenced w/POR & Driver.	Yes
MIC2214	150/300mA	2.25V to 5.5V	1.5/2.8, 1.6/2.8, 1.6/3.0, 1.6/3.3, 1.8/2.6, 1.8/2.7, 1.8/2.8, 1.8/2.9, 1.8/3.0, 1.8/3.3, 1.85/2.6, 1.85/2.65, 1.85/2.7, 1.85/2.85, 1.85/2.9, 2.5/1.8, 2.5/2.8, 2.5/3.0, 2.5/3.1, 2.6/2.6, 2.6/2.8, 2.6/2.85, 2.6/3.0, 2.7/2.8, 2.7/3.0, 2.8/2.8, 2.8/3.0, 2.85/2.85, 3.0/2.8, 3.0/2.85, 3.0/3.3, 3.0/1.6, 3.3/1.8, 3.3/2.8, 3.3/1.6, Adj/Adj.	48µA	120mV	MLF [®] (3mm x 3mm)	LDO w/POR & LED Driver.	Yes
MIC2219	150/300mA	2.25V to 5.5V	3.0/3.3	48µA	120mV	MLF [®] (3mm x 3mm)	Dynamically Adjustable µCap.	Yes
MIC5311	300/300mA	2.5V to 5.5V	1.8/2.8, 1.85/2.6, 2.85/2.7	28µA	120mV	MLF [®] (3mm x 3mm)	LowQ [®] Mode (7µA).	Yes
MIC5312	300/300mA	2.5V to 5.5V	1.8/2.8, 1.8/3.0, 1.85/2.6, 2.8/2.8, 2.85/2.85	28µA	120mV	MLF [®] (3mm x 3mm)	LowQ [®] Mode & POR (7µA).	Yes
MIC5313	300/300mA	1.7V to 5.5V	1.5/1.0, 1.5/1.1, 1.5/1.2, 1.5/1.3, 1.5/1.4, 1.5/1.5, 1.8/1.2, 1.8/1.8	37µA	85mV	Thin MLF [®] (2mm x 2mm)	Dual 300mA Low V _{IN} /Low V _{OUT} LDO.	Yes
MIC5314	300/300mA	1.7V to 5.5V	1.5/1.0, 1.5/1.1, 1.5/1.2, 1.5/1.3, 1.5/1.4, 1.5/1.5, 1.8/1.2, 1.8/1.8	37µA	85mV	Thin MLF [®] (2.5mm x 2.5mm)	Dual 300mA Low V _{IN} /Low V _{OUT} LDO with POR and CSET.	Yes
MIC5315	300/300mA	1.7V to 5.5V	1.5/1.0, 1.5/1.1, 1.5/1.2, 1.5/1.3, 1.5/1.4, 1.5/1.5, 1.8/1.2, 1.8/1.8	37µA	85mV	Thin MLF [®] (2mm x 2mm)	Dual 300mA Low V _{IN} /Low V _{OUT} LDO with Voltage Scaling.	Yes
MIC5316	300/300mA	1.7V to 5.5V	1.5/1.0, 1.5/1.1, 1.5/1.2, 1.5/1.3, 1.5/1.4, 1.5/1.5, 1.8/1.2, 1.8/1.8	37µA	85mV	Thin MLF [®] (2.5mm x 2.5mm)	Dual 300mA Low V _{IN} /Low V _{OUT} LDO with POR, CSET and Voltage Scaling.	Yes
MIC5330	300/300mA	2.3V to 5.5V	1.8/1.5, 1.8/1.5, 1.8/1.6, 2.5/1.8, 2.5/2.5, 2.6/1.85, 2.6/1.8, 2.7/2.7, 2.8/1.5, 2.8/1.8, 2.8/2.6, 2.8/2.8, 2.85/1.85, 2.85/2.6, 2.85/2.85, 2.9/1.5, 2.9/1.8, 2.9/2.9, 3.0/1.8, 3.0/2.5, 3.0/2.6, 3.0/2.8, 3.0/2.85, 3.0/3.0, 3.3/1.5, 3.3/1.8, 3.3/2.5, 3.3/2.6, 3.3/2.8, 3.3/2.85, 3.3/2.9, 3.3/3.0, 3.3/3.2, 3.3/3.3	75µA	75mV	MLF [®] (2mm x 2mm)	Tiny ULDO™ • Dual Enable • High PSRR	Yes

LDO Regulator Selection Guide

Multiple Outputs, DUAL (continued)

Device	I _{OUT}	V _{IN}	V _{OUT}	I _{GND} (Typ.)	V _{DROPOUT} (Typ.)	Package	Comments	μCap
MIC5331 <i>New!</i>	300/300mA		2.5/1.2, 2.8/2.8, 2.8/2.85, 2.85/2.85, 3.0/2.85, 3.0/3.0	40μA	120mV	Thin MLF [®] (2x2mm)	Dual Micro Power 300mA ULDO™	Yes
MIC5332 <i>New!</i>	300/300mA		2.5/1.2, 2.8/2.8, 2.8/2.85, 2.85/2.85, 3.0/2.85, 3.0/3.0	40μA	120mV	Thin MLF [®] (2mm x 2mm)	Dual Micro Power 300mA ULDO™ with POR and CSET	Yes
MIC5333 <i>New!</i>	300/300mA		2.5/1.2, 2.8/2.8, 2.8/2.85, 2.85/2.85, 3.0/2.85, 3.0/3.0	40μA	120mV	Thin MLF [®] (2.5 x 2.5mm)	Dual Micro Power 300mA ULDO™ with Two PORs and CSETs	Yes
MIC5335	300/300mA	2.3V to 5.5V	1.8/1.5, 1.8/1.8, 1.8/1.6, 2.5/1.8, 2.5/2.5, 2.6/1.85, 2.6/1.8, 2.7/2.7, 2.8/1.5, 2.8/1.8, 2.8/2.6, 2.8/2.8, 2.85/1.85, 2.85/2.6, 2.85/2.85, 2.9/1.5, 2.9/1.8, 2.9/2.9, 3.0/1.8, 3.0/2.5, 3.0/2.6, 3.0/2.8, 3.0/2.85, 3.0/3.0, 3.3/1.5, 3.3/1.8, 3.3/2.5, 3.3/2.6, 3.3/2.7, 3.3/2.8, 3.3/2.85, 3.3/2.9, 3.3/3.0, 3.3/3.2, 3.3/3.3,	75μA	75mV	Thin MLF [®] (1.6mm x 1.6mm)	High I _{OUT} . Ultra-small.	Yes
MIC5212	500/500mA	4.0V to 16V	3.3/2.5	1.5mA	350mV	SOIC	Small, High-Current Dual.	
MIC68220	2A/2A	1.65V to 5.5V	Adj./Adj.	15mA	300mV	MLF [®] (4mm x 5mm)	Trading and Ramp Control.	Yes

Multiple Outputs, TRIPLE

Device	I _{OUT}	V _{IN}	V _{OUT}	I _{GND} (Typ.)	V _{DROPOUT} (Typ.)	Package	Comments	μCap
MIC2215	250/250/250mA	2.25V to 5.5V	2.8/2.8/2.8, 3.0/2.8/2.8, 3.0/3.0/2.8, 3.0/3.0/1.8, 3.0/3.0/3.0, Adj/Adj/Adj	110μA/LDO	170mV	MLF [®] (4mm x 4mm)	Triple High PSRR μCap LDO.	Yes

LDO Controllers (N- and P-Channel), and DDR Terminators

MIC5156	—	3.0V to 36V	3.3, 5.0, Adj.	—	—	SOIC	Drives External N-Ch MOSFET.
MIC5157	—	3.0V to 36V	Selectable 3.3, 5.0, 12	—	—	PDIP, SOIC	Drives External N-Ch MOSFET.
MIC5158	—	3.0V to 36V	5.0, Adj.	—	—	PDIP, SOIC	Drives External N-Ch MOSFET.
MIC5159	—	1.65V to 5.5V	1.8, 3.0, Adj.	—	—	SOT-23	Low Input Voltage P-Ch MOSFET.
MIC5162	—	1.35V to 6V	—	—	—	MSOP	DDR Memory Termination.
MIC5190	—	0.9V to 5.5V	Adj. down to 0.5V	17mA	—	MSOP, MLF [®] (3mm x 3mm)	N-Ch Controller HBW>500kHz.
MIC5191	—	1.0V to 5.5V	Adj. down to 1.0V	17mA	—	MSOP, MLF [®] (3mm x 3mm)	N-Ch Controller HBW>500kHz.

Specific voltage/package options offered as noted on posted data sheets at: www.micrel.com.

T/SOT = Thin SOT-23 & SOT-23

ULDO™ = Ultra Low Dropout

HELDO™ (High Efficiency LDO)

Device	I _{OUT}	V _{IN}	V _{OUT}	Output Noise	Package	Comment
MIC38300	2.2A	3.0V to 5.5V	Adj. to 1V	5mV	MLF [®] (4mm x 6mm x 0.9mm)	Integrated switcher, LDO, inductor, ultra-low noise. Fast transient response. Ease-of-use.

Automotive (AEC-Q100 Qualified)

Device	I _{OUT}	V _{IN}	V _{OUT}	I _{GND} (Typ.)	V _{DROPOUT}	Package	Comment
MAQ5280 <i>New!</i>	25mA	4.5V to 120V	Adj.	31μA	1.1V	eSOIC-8	AEC-Q100 qualified, wide V _{IN} range.

Power Management Selection Guide

Device	I _{OUT}	V _{IN}	V _{OUT} ⁽¹⁾	I _{GND} (Typ.)	V _{DROPOUT} (Typ.)	Package	Comments
MIC2225	600/300mA	2.7V to 5.5V	1.2/2.6, 1.2/2.8, 1.2/2.9, 1.2/3.3, 1.8/1.2, 1.8/1.5, 1.8/2.5, 1.8/2.8		210mV	MLF-10 (2mm x 2mm)	Digital Power Management IC, 2MHz DC/DC converter with LDO.
MIC2800	600/300/300mA	2.7V to 5.5V	Adj./1.2/3.3, 1.87/1.2/2.8, 1.87/1.5/2.8, 1.8/1.2/2.5, 1.8/1.2/2.6, 1.8/1.2/3.3, 1.8/1.58/3.3, 1.8/1.52/2.8, 1.8/1.2/2.8	30µA	142mV	MLF-16 (3mm x 3mm)	Digital Power Management IC, 2MHz DC/DC converter with two Linear Regulators. LDO1 is directly connected to the output of the DC/DC converter. POR/Power Good pin.
MIC2807	600/200/30mA	2.7V to 5.5V	2.8/2.8, 2.85/2.85			MLF-17 (2.5mm x 2.8mm)	RF Power Management IC, 600mA DC/DC converter with DAC controlled output to power amplifier. 200mA RF LDO output current (provides bias voltage supply for PA), 30mA PA LDO (provides highly accurate PA reference voltage).
MIC2810	600/300/300mA	2.7V to 5.5V 1.65V to 5.5V	1.2/1.2/2.8, 1.2/1.8/2.6, 1.2/1.8/2.8, 1.2/1.8/3.0, 1.2/1.8/3.3, 1.2/2.7/3.3, 1.2/2.8/3.3, 1.0/1.8/2.5	38µA	142mV	MLF-16 (3mm x 3mm)	Digital Power Management IC, 2MHz with two Linear Regulators. LDO1 has a separate V _{IN} pin and can either post-regulate the DC/DC converter or be connected directly to the main input supply. POR/Power Good pin.
MIC2811	600/300/300/300mA	2.7V to 5.5V 1.65V to 5.5V 1.65V to 5.5V	1.2/1.8/2.5/2.7, 1.2/1.8/2.8/3.3		142mV	MLF-16 (3mm x 3mm)	2MHz DC/DC converter with 3 LDOs. Bypass cap for improved noise performance on LDO1 and 2. LDO1 and 2 have separate V _{IN} pins.
MIC2821	600/300/300/300mA	2.7V to 5.5V 1.65V to 5.5V 1.65V to 5.5V	1.2/1.8/2.5/2.7, 1.2/1.8/2.8/3.3		142mV	MLF-16 (3mm x 3mm)	2MHz DC/DC converter with 3 LDOs. LDO1 and 2 have separate V _{IN} pins. Independent enable for all four regulators.

1. Contact factory for additional output voltage options.

Battery Charger Selection Guide

Linear Battery Chargers

Device	Charge Cell Type	Charge Voltage	Voltage Accuracy	V _{IN}	I _{GND} (Typ.)	I _{GND} Shutdown (Typ.)	V _{DROPOUT} +25°C (Typ.)	V _{DROPOUT} Temp. Max.	Package
MIC79050	Li-Ion, 1 cell	4.2V	±0.75%	2.5V to 16V	85µA	3µA	380mV	600mV	MSOP, Power SOIC, SOT-223
MIC79110	Li-Ion	4.2V, Adj.	±0.75%	2.5V to 16V	2mA	0.1µA	375mV	550mV	MLF [®] (3mm x 3mm)

High-Side Load Switches Selection Guide

Micrel Advantange

- Lowest $R_{DS(on)}$
- Highest Power Handling
- Highest Current Drive Capability
- Soft-Start

Device	Type	Operating Voltage Min.	Operating Voltage Max.	Max. Switch Current	$R_{DS(on)}$ @5V	Load Discharge	Soft-Start	Enable Logic	Input Pull-Up Resistor	Reverse Current Blocking	Package
MIC94030	Single	2.7V	13.5V	1.0A	750mΩ			Low True		Yes	SOT-143
MIC94031	Single	2.7V	13.5V	1.0A	750mΩ			Low True	Yes	Yes	SOT-143
MIC94040	Single	1.7V	5.5V	3.0A	28mΩ			High True		No	MLF-4 (1.2mm x 1.2mm)
MIC94041	Single	1.7V	5.5V	3.0A	28mΩ	250Ω		High True		No	MLF-4 (1.2mm x 1.2mm)
MIC94042	Single	1.7V	5.5V	3.0A	28mΩ		100μs	High True		No	MLF-4 (1.2mm x 1.2mm)
MIC94043	Single	1.7V	5.5V	3.0A	28mΩ	250Ω	100μs	High True		No	MLF-4 (1.2mm x 1.2mm)
MIC94050	Single	1.8V	5.5V	1.8A	125mΩ			Low True		Yes	SOT-143
MIC94051	Single	1.8V	5.5V	1.8A	125mΩ			Low True	Yes	Yes	SOT-143
MIC94052	Single	1.8V	5.5V	2.0A	70mΩ			Low True		No	SC-70-6
MIC94053	Single	1.8V	5.5V	2.0A	70mΩ			Low True	Yes	No	SC-70-6
MIC94060	Single	1.7V	5.5V	2.0A	77mΩ			High True		No	SC-70-6, TMLF-4 (1.2mm x 1.6mm)
MIC94061	Single	1.7V	5.5V	2.0A	77mΩ	200Ω		High True		No	SC-70-6, TMLF-4 (1.2mm x 1.6mm)
MIC94062	Single	1.7V	5.5V	2.0A	77mΩ		800μs	High True		No	SC-70-6, TMLF-4 (1.2mm x 1.6mm)
MIC94063	Single	1.7V	5.5V	2.0A	77mΩ	200Ω	800μs	High True		No	SC-70-6, TMLF-4 (1.2mm x 1.6mm)
MIC94064	Single	1.7V	5.5V	2.0A	77mΩ		115μs	High True		No	SC-70-6, TMLF-4 (1.2mm x 1.6mm)
MIC94065	Single	1.7V	5.5V	2.0A	77mΩ	200Ω	115μs	High True		No	SC-70-6, TMLF-4 (1.2mm x 1.6mm)
MIC94066	Dual	1.7V	5.5V	2.0A	85mΩ			High True		No	MLF-8 (2mm x 2mm)
MIC94067	Dual	1.7V	5.5V	2.0A	85mΩ	200Ω		High True		No	MLF-8 (2mm x 2mm)
MIC94068	Dual	1.7V	5.5V	2.0A	85mΩ		800μs	High True		No	MLF-8 (2mm x 2mm)
MIC94069	Dual	1.7V	5.5V	2.0A	85mΩ	200Ω	800μs	High True		No	MLF-8 (2mm x 2mm)
MIC94070	Single	1.7V	5.5V	1.2A	120mΩ			High True		No	SC-70-6, TMLF-4 (1.2mm x 1.6mm)
MIC94071	Single	1.7V	5.5V	1.2A	120mΩ	200Ω		High True		No	SC-70-6, TMLF-4 (1.2mm x 1.6mm)
MIC94072	Single	1.7V	5.5V	1.2A	120mΩ		800μs	High True		No	SC-70-6, TMLF-4 (1.2mm x 1.6mm)
MIC94073	Single	1.7V	5.5V	1.2A	120mΩ	200Ω	800μs	High True		No	SC-70-6, TMLF-4 (1.2mm x 1.6mm)
MIC94080 <i>New!</i>	Single	1.7V	5.5V	2A	67mΩ			High True		No	TMLF-4 (0.85mm x 0.85mm)
MIC94081 <i>New!</i>	Single	1.7V	5.5V	2A	67mΩ	250Ω		High True		No	TMLF-4 (0.85mm x 0.85mm)
MIC94082 <i>New!</i>	Single	1.7V	5.5V	2A	67mΩ		850μs	High True		No	TMLF-4 (0.85mm x 0.85mm)
MIC94083 <i>New!</i>	Single	1.7V	5.5V	2A	67mΩ	250Ω	850μs	High True		No	TMLF-4 (0.85mm x 0.85mm)
MIC94084 <i>New!</i>	Single	1.7V	5.5V	2A	67mΩ		120μs	High True		No	TMLF-4 (0.85mm x 0.85mm)
MIC94085 <i>New!</i>	Single	1.7V	5.5V	2A	67mΩ	250Ω	120μs	High True		No	TMLF-4 (0.85mm x 0.85mm)

Switch-Mode Voltage Regulator Selection Guide

Micrel Advantange

- Best efficiency
- Highest speed
- Smallest solution size

Buck Regulators (Internal Switches)

Device	V _{IN} Range	V _{OUT}	I _{SW} ⁽¹⁾ (Avg)(Max)	Frequency	Package(s)	Comments
MIC4721	2.7V to 5.5V	Adj. to 1V	1.5A	2MHz	MSOP-10	Ultra-Fast Response Internal Compensation.
MIC4722	2.7V to 5.5V	Adj. to 1V	3A	2.7MHz	MLF-12 (3mm x 3mm)	Ultra-Fast, Ultra-Small.
MIC4723	2.7V to 5.5V	Adj. to 1V	3A	2MHz	MLF-12 (3mm x 3mm), eMSOP-10	Ultra-Fast, Ultra-Small.
MIC4724	6V	Adj. to 1V	3A	2MHz	eMSOP-10	Ultra-Fast, Ultra-Small.
MIC4742 <i>New!</i>	2.9V to 5.5V	Adj. to 0.6V	2A Dual Output	2MHz	MLF-16 (3mm x 3mm), eTSSOP-16	Integrated dual 2A switcher.
MIC4744 <i>New!</i>	2.9V to 5.5V	Adj. to 0.6V	2A Dual Output	4MHz	MLF-16 (3mm x 3mm), eTSSOP-16	High-efficiency, Integrated dual 2A switcher.
MIC2207	2.7V to 5.5V	Adj. to 1V	3A	2MHz	MLF-12 (3mm x 3mm)	Ultra-Fast, Ultra-Small.
MIC2208	2.7V to 5.5V	Adj. to 1V	3A	1MHz	MLF-12 (3mm x 3mm)	External Compensation.
MIC4720	2.7V to 5.5V	Adj. to 1V	2A	2MHz	MLF-12 (3mm x 3mm), eMSOP-10	Ultra-Fast, Ultra-Small.
MIC4680	4V to 34V	3.3V, 5V, Adj.	1.3A	200kHz	SOIC-8	
MIC4681	4V to 30V	Adj.	2A Peak	200kHz	SOIC-8	
MIC4682	4V to 34V	Adj.	2A	200kHz	SOIC-8	10% Precision Adjustable Current Limit.
MIC4684	4V to 30V	Adj.	2A	200kHz	SOIC-8	
MIC4685	4V to 30V	Adj.	3A	200kHz	SPAK-7	33% Smaller Than TO-263 (D2PAK).
MIC4690	4V to 30V	Adj.	1.3A	500kHz	SOIC-8	500kHz: Small Inductor.
MIC4574	4V to 24V	3.3V, 5V, Adj.	0.5A	200kHz	PDIP-8, SOIC-14	
MIC4575	4V to 24V	3.3V, 5V, Adj.	1A	200kHz	TO220-5, TO263-5	
MIC4576	4V to 36V	3.3V, 5V, Adj.	3A	200kHz	TO220-5, TO263-5	
LM2574	4V to 40V	3.3V, 5V, 12V, Adj.	0.5A	52kHz	PDIP-8	
LM2575	4V to 40V	3.3V, 5V, 12V, Adj.	1A	52kHz	TO220-5, TO263-5, PDIP-16, SOIC-24	
LM2576	4V to 40V	3.3V, 5V, 12V, Adj.	3A	52kHz	TO220-5, TO263-5	

1. I_{SW} (Avg) refers to the average current flowing through the switch.

Synchronous Buck Regulators (Internal Switches)

Device	V _{IN} Range	V _{OUT}	I _{SW} ⁽¹⁾ (Avg)(Max)	Frequency	Package(s)	Comments
MIC2177	4.5V to 16.5V	3.3V, 5V, Adj.	2.5A	200kHz	WSOIC-20	Auto-Skip Mode.
MIC2178	4.5V to 16.5V	3.3V, 5V, Adj.	2.5A	200kHz	WSOIC-20	Manual-Select Skip Mode.
MIC2179	4.5V to 16.5V	3.3V, 5V, Adj.	1.5A	200kHz	SSOP-20	
MIC2202	2.3V to 5.5V	Adj. to 0.5V	0.6A	2MHz	MSOP-10, MLF-10 (3mm x 3mm)	1μF Ceramic Stable.
MIC2203	2.3V to 5.5V	Adj. to 0.5V	0.3A	1MHz	MSOP-10, MLF-10 (3mm x 3mm)	1μF Ceramic Stable.
MIC2204	2.3V to 5.5V	Adj. to 1V	0.6A	2MHz	MSOP-10, MLF-10 (3mm x 3mm)	Synchronizable to External Clock.
MIC2205	2.7V to 5.5V	Adj.	0.6A	2MHz	MLF-10 (3mm x 3mm)	LowQ [®] LDO Mode. No Noise at Light Load.
MIC2245	2.7V to 5.5V	Adj.	0.5A	4MHz	MLF-10 (3mm x 3mm)	LowQ [®] LDO Mode. No Noise at Light Load.
MIC2285A	2.7V to 5.5V	Adj.	0.6A	8MHz	MLF-10 (2mm x 2mm)	LowQ [®] LDO Mode. No Noise at Light Load.
MIC2206	2.7V to 5.5V	1.8V(1.0V), 1.2V(1.0V)	0.6A	2MHz	MLF-10 (3mm x 3mm)	Voltage Scaling in LowQ [®] Mode.
MIC2224	2.7V to 5.5V	Adj. to 0.3V	0.6A	2MHz	MLF-10 (3mm x 3mm)	DAC Controlled V _{OUT} with Bypass Switch.
MIC22200 <i>New!</i>	2.6V to 5.5V	Adj. to 0.7V	2A	800kHz to 6MHz	MLF-12 (3mm x 3mm)	Sequencing/Tracking Easy Compensation.
MIC22400	2.6V to 5.5V	Adj. to 0.7V	4A	800kHz to 4MHz	MLF-20 (3mm x 4mm), eTSSOP-20	Sequencing/Tracking Easy Compensation.
MIC22600	2.6V to 5.5V	Adj. to 0.7V	6A	1MHz	MLF-24	Sequencing/Tracking Easy Compensation.
MIC23031	2.7V to 5.5V	1.0V, 1.2V, 1.5V, 1.8V, Adj.	0.4A	4MHz	MLF [®] (1.6mm x 1.6mm)	PWM Buck Regulator with HyperLight Load™.
MIC23030	2.7V to 5.5V	1.0V, 1.2V, 1.5V, 1.8V, Adj.	0.4A	8MHz	MLF [®] (1.6mm x 1.6mm)	PWM Buck Regulator with HyperLight Load™.
MIC23050	2.7V to 5.5V	1.2V, 1.8V, 3.3V	0.6A	4MHz	MLF [®] (2mm x 2mm)	PWM Buck Regulator with HyperLight Load™.
MIC23051	2.7V to 5.5V	1.2V(1.0V), 1.25V(0.95V), 1.4V(1.15V), 1.8V(1.0V),	0.6A	4MHz	MLF [®] (2mm x 2mm)	PWM Buck Regulator with HyperLight Load™ and Voltage Scaling.
MIC23150 <i>New!</i>	2.7V to 5.5V	1.0V, 1.2V, 1.8V, 3.3V	1.5A	4MHz	MLF [®] (2mm x 2mm)	PWM Buck Regulator with HyperLight Load™.

Synchronous Buck Regulators (Internal Switches + Internal Inductor)

Device	V _{IN} Range	V _{OUT}	I _{SW} ⁽¹⁾ (Avg)(Max)	Frequency	Package(s)	Comments
MIC33050	2.7V to 5.5V	1.2V, 1.8V, 3.3V	0.6A	4MHz	MLF-12 (3mm x 3mm)	4MHz Operation with Internal Chip Inductor.
MIC3385	2.7V to 5.5V	1.5V, Adj.	0.6A	8MHz	MLF-14 (3mm x 3.5mm)	8MHz Operation with Internal Chip Inductor, HyperLight Load™.

Switch-Mode Voltage Regulator Selection Guide

Dual Synchronous Buck Regulators (Internal Switches)

Device	V _{IN} Range	V _{OUT}	I _{SW} ⁽¹⁾ (Avg)(Max)	Frequency	Package(s)	Comments
MIC2238	2.5V to 5.5V	1.2/1.8V, 1.2/1.5V, 1.2/2.5V, 1.2/3.3V, 1.0/1.5V, 1.0/1.8V, 1.0/2.5V, Adj./Adj.	800/800mA	2.5MHz	MLF-12 (3mm x 3mm)	POR/PG Pin. Trickle Mode™ at Light Load. Independent Enables.
MIC23250	2.7V to 5.5V	1.2/1.8V, 1.0/1.2V, 0.9/1.1V, 1.2/1.6V, 1.2/2.5V, 1.2/3.3V, 2.6/3.3V, Adj./Adj.	400/400mA	4MHz	MLF-10 (2mm x 2mm)	PWM Buck Regulators with HyperLight Load™. Independent Enables.

Buck Controllers (External Switches)

Device	V _{IN} Range	V _{OUT}	I _{SW} ⁽¹⁾ (Avg)(Max)	Efficiency (Typ)	I _Q (Typ)	Shutdown I _Q (Typ)	Frequency	Package(s)	Comments
MIC2184	2.9V to 16V	Adj.	External P-FET, 1A to 10A	90%	600µA	0.5µA	200/400kHz	SOIC-16 QSOP-16	Can also be configured as Buck-Boost Buck-Boost
MIC2194	2.9V to 14V	Adj.	External P-FET, 1A to 10A	90%	1mA	0.5µA	400kHz	SOIC-8	

Synchronous Buck Controllers (External Switches)

Device	V _{IN} Range	V _{OUT}	I _{SW} ⁽¹⁾ (Avg)(Max)	Efficiency (Typ)	I _Q (Typ)	Shutdown I _Q (Typ)	Frequency	Package(s)	Comments
MIC2130	8V to 40V	Adj. to 0.7V	External FETs, 15A				150/400kHz	MLF-16, eTSSOP-16	
MIC2131	8V to 40V	Adj. to 0.7V	External FETs, 15A				150/400kHz	MLF-16, eTSSOP-16	Low EMI Frequency Dithering.
MIC2168	3V to 14.5V	Adj. to 0.8V	External N-FETs, 10A	95%	1mA	50µA	1MHz	MSOP-10	Small and Fast.
MIC2168A	3V to 14.5V	Adj. to 0.8V	External N-FETs, 10A	95%	1mA	50µA	1MHz	MSOP-10	Small and Fast, Enable Function.
MIC2169	3V to 14.5V	Adj. to 0.8V	External N-FETs, 15A	95%	1mA	50µA	500kHz	MSOP-10	Small and Super Efficient.
MIC2169A	3V to 14.5V	Adj. to 0.8V	External N-FETs, 15A				500kHz	MSOP-10	Small and Super Efficient; Enable Function.
MIC2159	3V to 14.5V	Adj. to 0.8V	External N-FETs, 20A				400kHz	EPAD-MSOP-10	Higher Current, Enable Function.
MIC2182	4.5V to 32V	3.3V, 5V, Adj.	External N-FETs, 2.5A to 20A	90%+	600µA	2µA	300kHz	SOIC-16, TSSOP-16	
MIC2183	2.9V to 14V	Adj. to 1.25V	External N- and P-FET, 1A to 10A	95%+	600µA	0.5µA	400/200kHz	MSOP-16, QSOP-16	100% Max. Duty Cycle.
MIC2193	2.9V to 14V	Adj.	External N- and P-FET, 1A to 10A	93%+	1mA	–	400kHz	SOIC-8	100% Max. Duty Cycle.
MIC2198	4.5V to 32V	Adj. To 0.8V	External N-FETs, 1A to 20A	95%+	3.5mA	0.1µA	500kHz	MLF-12 (4mm x 4mm)	
MIC2199	4.5V to 32V	Adj. To 0.8V	External N-FETs, 1A to 20A	95%+	1.6mA	0.1µA	300kHz	MLF-12 (4mm x 4mm)	

1. I_{SW} (Avg) refers to the average current flowing through the switch.

Boost Regulators (Internal Switches)

Device	V _{IN} Range	V _{OUT}	I _{SW} (Typ)	Frequency	Package(s)	Comments
MIC2141	2.5V to 14V	Adj. to 22V	0.1A	330kHz	SOT-23-5	Dynamically Adjustable V _{OUT} for LCD Bias.
MIC2142	2.2V to 16V	Adj. to 22V	0.1A	330kHz	SOT-23-5	
MIC2145	2.4V to 16V	Adj. to 16V	1A	450kHz	MSOP-8, MLF-10 (3mm x 3mm)	
MIC2171	3V to 40V	Adj. to 60V	4A	100kHz	TO-220-5, TO-263-5	High-Current, High-Voltage.
MIC2172	3V to 40V	Adj. to 60V	2.5A	100kHz	SOIC-8, DIP-8	Sync Pin., High-Current, High-Voltage.
MIC2288	2.5V to 10V	Adj. to 34V	1.2A	1.2MHz	TSOT-23-5, MLF-8 (2mm x 2mm)	OLED Driver, High Accuracy, OVP.
MIC2289	2.5V to 10V	Adj. to 34V	0.75A	1.2MHz	MLF-8 (2mm x 2mm)	Internal Schottky White LED Driver, OVP.
MIC2570	1.3V to 15V	2.85V, 3.3V, 5V, Adj. to 33V	1.1A	20kHz	SOIC-8	Low Input Voltage.
MIC2571	0.9V to 15V	2.85V, 3.3V, 5V, Adj. to 33V	1.1A	20kHz	SOIC-8	Low Input Voltage.
MIC2250 <i>New!</i>	2.5V to 5.5V	Adj. to 32V	2.0A	Up to 2.5MHz	MLF-8 (2mm x 2mm)	High Light Load Efficiency Boost Regulator with low EMI.
MIC2290	2.5V to 10V	Adj. to 34V	0.75A	1.2MHz	MLF-8 (2mm x 2mm)	Internal Schottky, OVP.
MIC2295	2.5V to 10V	Adj. to 34V	1.2A	1.2MHz	TSOT-23-5, MLF-8 (2mm x 2mm)	High-Current, High-Efficiency, OVP.
MIC2296	2.5V to 10V	Adj. to 34V	1.7A	0.6MHz	TSOT-23-5, MLF-8 (2mm x 2mm)	High-Current, High-Efficiency, OVP.
MIC2297	2.5V to 10V	Adj. to 40V	1.2A	0.6MHz	MLF-10 (2mm x 2mm)	High Voltage White LED Driver, OVP.
MIC2298	2.5V to 10V	Adj. to 15V	4.75A	1.0MHz	MLF-12 (3mm x 3mm)	High Power Photo Flash LED Driver with Torch Mode, OVP.
MIC2299	2.5V to 10V	Adj. to 30V	4.75A	2.0MHz	MLF-12 (3mm x 3mm)	High Power Photo Flash LED Driver with Torch Mode, OVP.
MIC2601/2	4.5V to 20V	Adj. to 40V	1.2A	1.2/2MHz	MLF-8 (2mm x 2mm)	Enable Pin/SS/ Low Shutdown Current.
MIC2605/6	4.5V to 20V	Adj. to 40V	0.5A	1.2/2MHz	MLF-8 (2mm x 2mm)	Enable Pin/SS/ Low Shutdown Current. Integrated Schottky.
MIC3172	3V to 40V	Adj. to 34V	2.25A	100kHz	SOIC-8, PDIP-8	Enable Pin.

Switch-Mode Voltage Regulator Selection Guide

Boost Controllers (External Switches)

Device	V _{IN} Range	V _{OUT}	Output Current	Efficiency (Typ)	I _Q (Typ)	Shutdown I _Q (Typ)	Frequency	Package(s)	Comments
MIC2186	2.9V to 14V	Adj.	External N-FET, 1A to 10A	90%	600µA	0.5µA	100/200/400kHz	SOIC-16, QSOP-16	
MIC2196	2.9V to 14V	Adj.	External N-FET, 1A to 10A	90%	1mA	0.5µA	400kHz	SOIC-8	Boost, SEPIC, Cuk Configurations.

Synchronous Boost Controllers (External Switches)

MIC2185	2.9V to 14V	Adj.	External N-FET/P-FET, 1A to 10A	95%	600µA	0.5µA	400kHz	SOIC-8	High Efficiency.
---------	-------------	------	---------------------------------	-----	-------	-------	--------	--------	------------------

Flyback/Forward Converter/Push-Pull Controllers for Isolated Applications (External Switches)

Device	V _{IN} Range	Gate Drive	V _{START}	V _{STOP}	Start-Up Current (Max)	Duty Cycle (Max)	Topology	Frequency	Package(s)	Comments
MIC9130	9V to 180V	1A	9V	–	–	50%	Forward/Flyback	Adj. to 1.5MHz	SOIC-16, QSOP-16	Fast. Built-in 180V Start-up Circuitry.
MIC9131	9V to 180V	1A	9V	–	–	75%	Forward/Flyback	Adj. to 1MHz	SOIC-16, QSOP-16	Fast. Built-in 180V Start-up Circuitry.
MIC3808	8.3V to 15V	0.5A	12.5V	8.3V	130µA	50%	Push-Pull	Adj. to 1MHz	SOIC-8, MSOP-8	High-Output Current.
MIC3809	4.1V to 15V	0.5A	4.3V	4.1V	130µA	50%	Push-Pull	Adj. to 1MHz	SOIC-8, MSOP-8	High-Output Current.
MIC3838	8.3V to 15V	0.5A	12.5V	8.3V	130µA	50%	Push-Pull	Adj. to 1MHz	MSOP-10	Can Implement Volt-Second Clamp.
MIC3839	4.1V to 15V	0.5A	4.3V	4.1V	130µA	50%	Push-Pull	Adj. to 1MHz	MSOP-10	Can Implement Volt-Second Clamp.
MIC38C42	15.5V to 20V	0.5A	14.5V	9.0V	200µA	96%	Forward/Flyback	Adj. to 500kHz	PDIP-8, -14, MSOP-8 SOIC-8, -14	
MIC38C43	9V to 20V	0.5A	8.4V	7.6V	200µA	96%	Forward/Flyback	Adj. to 500kHz	PDIP-8, -14, MSOP-8 SOIC-8, -14	
MIC38C44	15.5V to 20V	0.5A	14.5V	9.0V	200µA	50%	Forward/Flyback	Adj. to 500kHz	PDIP-8, -14, MSOP-8 SOIC-8, -14	
MIC38C45	9V to 20V	0.5A	8.4V	7.6V	200µA	50%	Forward/Flyback	Adj. to 500kHz	PDIP-8, -14, MSOP-8 SOIC-8, -14	
MIC38HC42	15.5V to 20V	1A	14.5V	9.0V	200µA	96%	Forward/Flyback	Adj. to 500kHz	PDIP-8, -14, SOIC-8, -14	
MIC38HC43	9V to 20V	1A	8.4V	7.6V	200µA	96%	Forward/Flyback	Adj. to 500kHz	PDIP-8, -14, SOIC-8, -14	
MIC38HC44	15.5V to 20V	1A	14.5V	9.0V	200µA	50%	Forward/Flyback	Adj. to 500kHz	PDIP-8, -14, SOIC-8, -14	
MIC38HC45	9V to 20V	1A	8.4V	7.6V	200µA	50%	Forward/Flyback	Adj. to 500kHz	PDIP-8, -14, SOIC-8, -14	
MIC38C42A ⁽¹⁾	15.5V to 20V	0.5A	14.5V	9.0V	200µA	96%	Forward/Flyback	Adj. to 500kHz	SOIC-8, -14	
MIC38C43A ⁽¹⁾	9V to 20V	0.5A	14.5V	9.0V	200µA	96%	Forward/Flyback	Adj. to 500kHz	SOIC-8, -14	
MIC38C44A ⁽¹⁾	15.5V to 20V	0.5A	14.5V	9.0V	200µA	50%	Forward/Flyback	Adj. to 500kHz	SOIC-8, -14	
MIC38C45A ⁽¹⁾	9V to 20V	0.5A	14.5V	9.0V	200µA	50%	Forward/Flyback	Adj. to 500kHz	SOIC-8, -14	

1. Recommended for new designs.

WLED Driver Selection Guide

Boost LED Drivers

Device	V _{IN} Range	V _{OUT}	I _{sw} (Typ)	Frequency	Package(s)	Comments
MIC2287	2.5V to 10V	Adj. to 34V	0.75A	1.2MHz	TSOT-23-5, MLF-8 (2mm x 2mm)	White LED Driver.
MIC2287C	2.5V to 10V	Adj. to 34V	0.75A	1.2MHz	TSOT-23-5, MLF-8 (2mm x 2mm)	White LED Driver. 10% ILED accuracy
MIC2289	2.5V to 10V	Adj. to 34V	0.75A	1.2MHz	MLF-8 (2mm x 2mm)	Internal Schottky White LED Driver, OVP.
MIC2291	2.5V to 10V	Adj. to 34V	1.2A	1.2MHz	TSOT23-5, MLF-8 (2mm x 2mm)	Photo Flash LED Driver, OVP.
MIC2292	2.5V to 10V	Adj. to 34V	0.5A	1.6MHz	MLF-8 (2mm x 2mm)	High-Frequency White LED Driver with Internal Schottky Diode, OVP.
MIC2293	2.5V to 10V	Adj. to 34V	0.5A	2MHz	MLF-8 (2mm x 2mm)	High-Frequency White LED Driver with Internal Schottky Diode, OVP.
MIC2293C	2.5V to 10V	Adj. to 34V	0.5A	2MHz	MLF-8 (2mm x 2mm)	High-Frequency White LED Driver with Internal Schottky Diode, OVP. 10% ILED accuracy
MIC2297	2.5V to 10V	Adj. to 40V	1.2A	0.6MHz	MLF-10 (2mm x 2mm)	High Voltage White LED Driver, OVP.
MIC2298	2.5V to 10V	Adj. to 15V	4.75A	1.0MHz	MLF-12 (3mm x 3mm)	High Power Photo Flash LED Driver with Torch Mode, OVP.
MIC2299	2.5V to 10V	Adj. to 30V	4.75A	2.0MHz	MLF-12 (3mm x 3mm)	High Power Photo Flash LED Driver with Torch Mode.
MIC3287	2.8V to 5.5V	Adj. to 24V	0.35A	1.2MHz	TSOT-23-5, TSOT-23-6, MLF-8 (2mm x 2mm)	White LED Driver.
MIC3289	2.5V to 6.5V	Adj. to 24V	0.5A	1.2MHz	TSOT-23-6, MLF-8 (2mm x 2mm)	Single Wire Digital Brightness Control with Internal Schottky Diode.

Linear LED Drivers

Device	V _{IN} Range	Output	Dimming	I _{LED} Matching	LDOs	Package(s)	Comments
MIC2841A <i>New!</i>	3.0V to 5.5V	4 x 20mA	PWM to 500kHz	1.5%	–	Thin MLF-10 (2mm x 2mm)	Linear WLED Driver.
MIC2842A <i>New!</i>	3.0V to 5.5V	4 x 20mA	32-Step Digital	1.5%	–	Thin MLF-10 (2mm x 2mm)	Linear WLED Driver.
MIC2843A <i>New!</i>	3.0V to 5.5V	6 x 20mA	PWM to 500kHz	1.5%	–	Thin MLF-10 (2mm x 2mm)	Linear WLED Driver.
MIC2844A <i>New!</i>	3.0V to 5.5V	6 x 20mA	32-Step Digital	1.5%	–	Thin MLF-10 (2mm x 2mm)	Linear WLED Driver.
MIC2845A <i>New!</i>	3.0V to 5.5V	6 x 20mA	PWM to 500kHz	1.5%	2	Thin MLF-14 (2.5mm x 2.5mm)	Linear WLED Driver with 2 LDOs.
MIC2846A <i>New!</i>	3.0V to 5.5V	6 x 20mA	32-Step Digital	1.5%	2	Thin MLF-14 (2.5mm x 2.5mm)	Linear WLED Driver with 2 LDOs.

High Power LED Drivers

Device	V _{IN} Range	I _{LED}	Dimming	Switching Frequency	I _{LED} Accuracy	Feedback Looping	Package(s)	Comments
MIC3230 <i>New!</i>	6V to 45V	Controller (external FET)	PWM	100 to 1MHz	3%	250mV	eTSSOP-16, MLF-12 (3mm x 3mm)	Boost Controller High Power LED Driver.
MIC3231 <i>New!</i>	6V to 45V	Controller (external FET)	PWM	to 1MHz	3%	250mV	eTSSOP-16 MLF-12 (3mm x 3mm)	Boost Controller High Power LED Driver with filtering.
MIC3232 <i>New!</i>	6V to 45V	Controller (external FET)	PWM	400kHz	3%	250mV	MSOP-10	Fixed Frequency Boost Controller High Power LED Driver

Switch-Mode Voltage Regulator DC-to-DC Topologies

Device	Typical Applications	Pros	Cons
MIC5203 MIC5205 MIC5219 MIC5245 MIC2940A	MIC39100 MIC39150 MIC47100* MIC69103* MIC69153* MIC69302*	Linear Regulator Only Steps Down ($V_{OUT} < V_{IN}$) <ul style="list-style-type: none"> - Inexpensive - Very Small - Low Noise/EMI - Ideal for: <ul style="list-style-type: none"> - 3.3V to 2.5V - 2.5V to 1.8V - 1.8V to 1.2V 	Inefficient at high input to output voltage differential $Eff = V_{OUT}/V_{IN}$ <i>Note:</i> If a linear regulator gets too hot, then use a buck switching regulator instead or the new HELDO™ MIC38300.
LM257x MIC457x MIC2207 MIC2208 MIC4680* MIC4681* MIC4682* MIC4684*	MIC4685* MIC4690* MIC4720* MIC4721* MIC4722* MIC4723* MIC4724* MIC4724*	Buck Regulator (Internal Switch) Only Steps Down ($V_{OUT} < V_{IN}$) <ul style="list-style-type: none"> - Lowest Peak Current - Only One Switch Voltage Drop - Low-Ripple Current In <ul style="list-style-type: none"> - Output-Filter Capacitor - Simple Inductor - Low Switch-Stress Voltage $Eff = +85\%$	High-Side Switch $I_{SW} (Avg) \approx I_{OUT}$ $DC \approx \frac{V_{OUT}}{V_{IN} \times Eff}$
MIC2177* MIC2178* MIC2179* MIC2202* MIC2203* MIC2204* MIC2205*	MIC2206* MIC2224* MIC2245* MIC2285* MIC22400* MIC22600* MIC23xxx	Synchronous Buck Regulator (Internal Switch) High Efficiency Step Down <ul style="list-style-type: none"> - Highest Efficiency (+90%) - Pros are same as Buck - High Output Current (Up to 20A) 	Two Switches $I_{SW} (Avg) \approx I_{OUT}$ $DC \approx \frac{V_{OUT}}{V_{IN} \times Eff}$
MIC2130/1* MIC2159* MIC2168A* MIC2169A* MIC2182*	MIC2183 MIC2193* MIC2198* MIC2199* MIC2182*	Synchronous Buck Regulator (External Switch) High Efficiency Step Down <ul style="list-style-type: none"> - Highest Efficiency (+90%) - Pros are same as Buck - High Output Current (Up to 20A) 	Two Switches $I_{SW} (Avg) \approx I_{OUT}$ $DC \approx \frac{V_{OUT}}{V_{IN} \times Eff}$
MIC2142* MIC2145* MIC2186* MIC2288 MIC2290 MIC2570*	MIC2601/2 MIC2605/6 MIC3172* MIC2171* MIC3289*	Boost Only Steps Up ($V_{OUT} > V_{IN}$) <ul style="list-style-type: none"> - Low Peak Current - Low-Side Switch - Simple Inductor - Low Switch-Stress Voltage $Eff \approx 85\%$	Output can't be completely turned off. No short-circuit protection. $I_{SW} (Avg) \approx \frac{V_{OUT} \times I_{OUT}}{V_{IN} \times Eff.}$ $DC \approx \frac{V_{OUT} - (V_{IN} \times Eff.)}{V_{OUT}}$
MIC2196* LM257x MIC457x	MIC4680 MIC4681 MIC4690	Inverter/Buck Boost Negative Output Only <ul style="list-style-type: none"> - Simple Inductor $Eff \approx 80\%$	High-Side Switch High Peak Currents $I_{SW} (Avg) \approx \frac{V_{OUT} \times I_{OUT} + I_{OUT}}{V_{OUT} \times Eff.}$ $DC \approx \frac{V_{OUT}}{V_{OUT} + (V_{IN} \times Eff.)}$
MIC38HC4x MIC38C4x		Forward Step Up and Down <ul style="list-style-type: none"> - Isolated Outputs - Low Side Switch - Low Input/Output Ripple $Eff \approx 90\%$	$I_{SW} (Avg) \approx \frac{n_s}{n_p} \times I_{OUT}$ $DC \approx \frac{V_{OUT}}{(Eff \times V_{IN})} \times \frac{n_p}{n_s}$

Note:

* = evaluation board is available.

Switch-Mode Voltage Regulator DC-to-DC Topologies

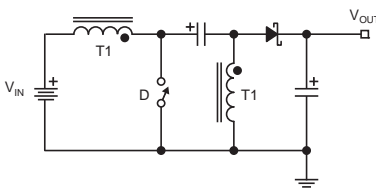
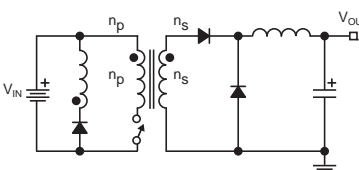
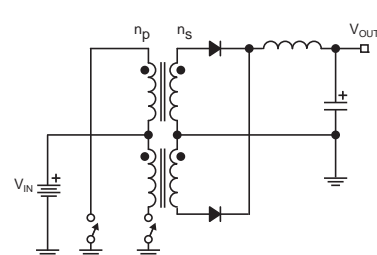
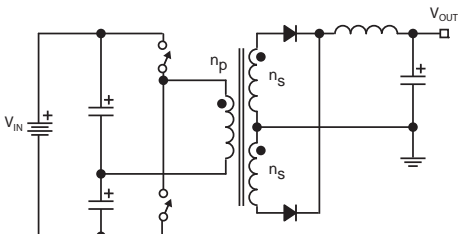
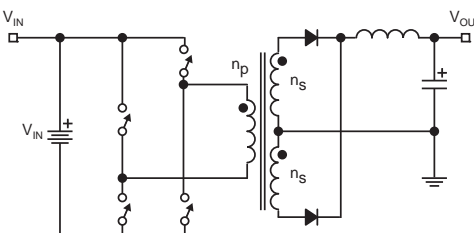
Device	Typical Applications	Pros	Cons	
MIC2171 MIC2186* MIC2196* MIC38C4x	MIC38HC4x MIC9130** (POE) MIC9131*		Flyback Applications (External Switches) Step Up and Down Isolated Output Multiple Outputs Negative Output High Output Voltage – Low-Side Switch Eff ≈ 80%	Transformer instead of Inductor High Peak Current High Switch-Stress Voltage $I_{SW} (Avg) \approx \frac{2 \times V_{OUT} \times I_{OUT}}{V_{IN} \times Eff.}$ DC ≈ Duty Cycle DC ≈ Assume 50%
MIC2142* MIC2145* MIC2171* MIC2172* MIC2186*	MIC2196* MIC2288* MIC2295* MIC2570* MIC3172*		SEPIC Step Up and Down – Low-Side Switch Eff ≈ 80%	High Peak Currents 2 inductors or coupled inductor. High Switch-Stress Voltage $I_{SW} (Avg) \approx \frac{V_{OUT} \times I_{OUT} + I_{OUT}}{V_{OUT} \times Eff.}$ $DC \approx \frac{V_{OUT}}{V_{OUT} + (V_{IN} \times Eff.)}$
MIC3808/9 MIC3838/9			Push-Pull Step Up and Down – Isolated Outputs – Low Side Switches – Low Input/Output Ripple Eff ≈ 94%	$I_{SW} (Avg) \approx \frac{n_s}{n_p} \times I_{OUT}$ $DC \approx \frac{V_{OUT}}{2(Eff \times V_{IN})} \times \frac{n_p}{n_s}$
MIC3808 MIC3809* MIC3838/9			Half-Bridge Step Up and Down – Isolated Outputs – Low FET Stress – Low Transformer Leakage Eff ≈ 95%	$I_{SW} (Avg) \approx \frac{n_s}{n_p} \times I_{OUT}$ $DC \approx \frac{V_{OUT}}{2(Eff \times V_{IN})} \times \frac{n_p}{n_s}$
MIC3808 MIC3809* MIC3838/9			Full-Bridge Step Up and Down – Isolated Outputs – High Power – Low FET Stress Eff ≈ 95%	$I_{SW} (Avg) \approx \frac{n_s}{n_p} \times I_{OUT}$ $DC \approx \frac{V_{OUT}}{2(Eff \times V_{IN})} \times \frac{n_p}{n_s}$

Note:
* = evaluation board is available.

General Purpose Power Distribution Switch Selection Guide

Micrel Advantage

- Highest Efficiency
- Highest Current Density
- Low $R_{DS\ ON}$
- Best CLS Performance

Device	Type	Switch Element	Internal Charge Pump	Operating Voltage	Current Limit Fixed (Min.)	Adj. (Max.)	Output Resistance	Body Diode Blocking	Enable Logic	Under Voltage Lockout	Current Limit	Thermal Shutdown	Fault Flag	Flag Transient Filter	Package
MIC2003/13	Single	P-Channel	n/a	2.5V to 5.5V	500mA 800mA 1.2A		100mΩ@5V	No	Noninverting	Yes	Yes	Yes	No	Yes	SOT-23-6, MLF® (2mm x 2mm)
MIC2004/14	Single	P-Channel	n/a	2.5V to 5.5V	500mA 800mA 1.2A		100mΩ@5V	No	Noninverting	Yes	Yes	Yes	No	Yes	SOT-23-6, MLF® (2mm x 2mm)
MIC2005/15	Single	P-Channel	n/a	2.5V to 5.5V	500mA 800mA 1.2A		10mΩ@5V	No	Noninverting	Yes	Yes	Yes	Yes	Yes	SOT-23-6, MLF® (2mm x 2mm)
MIC2005A <i>New!</i>	Single	P-Channel	n/a	2.5V to 5.5V	500mA		170mΩ@5V	No	Noninverting	Yes	Yes	Yes	Yes	Yes	SOT-23-5, SOT-23-6
MIC2005L <i>New!</i>	Single	P-Channel	n/a	2.5V to 5.5V	500mA 800mA 1.2A		100mΩ@5V	No	Noninverting	Yes	Yes	Yes	Yes	Yes	SOT-23-5
MIC2006/16	Single	P-Channel	n/a	2.5V to 5.5V	500mA 800mA 1.2A		100mΩ@5V	No	Noninverting	Yes	Yes	Yes	No	Yes	SOT-23-6, MLF® (2mm x 2mm)
MIC2007/17	Single	P-Channel	n/a	2.5V to 5.5V	200mA 2.0A		100mΩ@5V	No	Noninverting	Yes	Yes	Yes	No	Yes	SOT-23-6, MLF® (2mm x 2mm)
MIC2008/18	Single	P-Channel	n/a	2.5V to 5.5V	200mA 2.0A		100mΩ@5V	No	Noninverting	Yes	Yes	Yes	No	Yes	SOT-23-6, MLF® (2mm x 2mm)
MIC2009/19	Single	P-Channel	n/a	2.5V to 5.5V	200mA 2.0A		100mΩ@5V	No	Noninverting	Yes	Yes	Yes	Yes	Yes	SOT-23-6, MLF® (2mm x 2mm)
MIC2025-1	Single	N-Channel	Yes	2.7V to 5.5V	500mA		140mΩ@5V	Yes	Noninverting	Yes	Yes	Yes	Yes	Yes	SOIC-8, MSOP-8
MIC2025-2	Single	N-Channel	Yes	2.7V to 5.5V	500mA		140mΩ@5V	Yes	Inverting	Yes	Yes	Yes	Yes	Yes	SOIC-8, MSOP-8
MIC2026-1	Dual	N-Channel	Yes	2.7V to 5.5V	500mA		140mΩ@5V	Yes	Noninverting	Yes	Yes	Yes	Yes	Yes	SOIC-8, DIP-8
MIC2026-2	Dual	N-Channel	Yes	2.7V to 5.5V	500mA		140mΩ@5V	Yes	Inverting	Yes	Yes	Yes	Yes	Yes	SOIC-8, DIP-8
MIC2027-1	Quad	N-Channel	Yes	2.7V to 5.5V	500mA		150mΩ@5V	Yes	Noninverting	Yes	Yes	Yes	Yes	Yes	SOIC-16
MIC2027-2	Quad	N-Channel	Yes	2.7V to 5.5V	500mA		150mΩ@5V	Yes	Inverting	Yes	Yes	Yes	Yes	Yes	SOIC-16
MIC2040-1	Single	N-Channel	Yes	0.8V to 5.5V	250mA 1.5A		80mΩ@5V	Yes	Noninverting	Yes	Yes	Yes	Yes	Yes	MSOP-10
MIC2040-2	Single	N-Channel	Yes	0.8V to 5.5V	250mA 1.5A		80mΩ@5V	Yes	Inverting	Yes	Yes	Yes	Yes	Yes	MSOP-10
MIC2041-1	Single	N-Channel	Yes	0.8V to 5.5V	250mA 1.5A		80mΩ@5V	Yes	Noninverting	Yes	Latched	Yes	Yes	Yes	MSOP-10
MIC2041-2	Single	N-Channel	Yes	0.8V to 5.5V	250mA 1.5A		80mΩ@5V	Yes	Inverting	Yes	Latched	Yes	Yes	Yes	MSOP-10
MIC2042-1	Single	N-Channel	Yes	0.8V to 5.5V	500mA 3.0A		40mΩ@5V	Yes	Noninverting	Yes	Yes	Yes	Yes	Yes	SOIC-8, TSSOP-14
MIC2042-2	Single	N-Channel	Yes	0.8V to 5.5V	500mA 3.0A		40mΩ@5V	Yes	Inverting	Yes	Yes	Yes	Yes	Yes	SOIC-8, TSSOP-14
MIC2043-1	Single	N-Channel	Yes	0.8V to 5.5V	500mA 3.0A		40mΩ@5V	Yes	Noninverting	Yes	Latched	Yes	Yes	Yes	SOIC-8, TSSOP-14
MIC2043-2	Single	N-Channel	Yes	0.8V to 5.5V	500mA 3.0A		40mΩ@5V	Yes	Inverting	Yes	Latched	Yes	Yes	Yes	SOIC-8, TSSOP-14
MIC2044-1	Single	N-Channel	Yes	0.8V to 5.5V	1.0A 6.0A		20mΩ@5V	Yes	Noninverting	Yes	Yes	Yes	Yes	Yes	TSSOP-16
MIC2044-2	Single	N-Channel	Yes	0.8V to 5.5V	1.0A 6.0A		20mΩ@5V	Yes	Inverting	Yes	Yes	Yes	Yes	Yes	TSSOP-16
MIC2045-1	Single	N-Channel	Yes	0.8V to 5.5V	1.0A 6.0A		20mΩ@5V	Yes	Noninverting	Yes	Latched	Yes	Yes	Yes	TSSOP-16
MIC2045-2	Single	N-Channel	Yes	0.8V to 5.5V	1.0A 6.0A		20mΩ@5V	Yes	Inverting	Yes	Latched	Yes	Yes	Yes	TSSOP-16
MIC2075-1	Single	N-Channel	Yes	2.7V to 5.5V	500mA		140mΩ@5V	Yes	Noninverting	Yes	Yes	Latched	Yes	Yes	SOIC-8, MSOP-8
MIC2075-2	Single	N-Channel	Yes	2.7V to 5.5V	500mA		140mΩ@5V	Yes	Inverting	Yes	Yes	Latched	Yes	Yes	SOIC-8, MSOP-8
MIC2076-1	Dual	N-Channel	Yes	2.7V to 5.5V	500mA		140mΩ@5V	Yes	Noninverting	Yes	Yes	Latched	Yes	Yes	SOIC-8, DIP-8
MIC2076-2	Dual	N-Channel	Yes	2.7V to 5.5V	500mA		140mΩ@5V	Yes	Inverting	Yes	Yes	Latched	Yes	Yes	SOIC-8, DIP-8
MIC2077-1	Quad	N-Channel	Yes	2.7V to 5.5V	500mA		150mΩ@5V	Yes	Noninverting	Yes	Yes	Latched	Yes	Yes	SOIC-16
MIC2077-2	Quad	N-Channel	Yes	2.7V to 5.5V	500mA		150mΩ@5V	Yes	Inverting	Yes	Yes	Latched	Yes	Yes	SOIC-16
MIC2505	Single	N-Channel	Yes	2.7V to 7.5V	2.0A		50mΩ@5V	Yes	Noninverting		Yes	Yes	Yes	Yes	SOIC-8
MIC2505-1	Single	N-Channel	Yes	2.7V to 7.5V	2.0A		50mΩ@5V	Yes	Noninverting		Yes	Yes	Yes	Yes	SOIC-8
MIC2505-2	Single	N-Channel	Yes	2.7V to 7.5V	2.0A		50mΩ@5V	Yes	Inverting		Yes	Yes	Yes	Yes	SOIC-8
MIC2506	Dual	N-Channel	Yes	2.7V to 7.5V	1.0A		125mΩ@5V	Yes	Noninverting		Yes	Yes	Yes	Yes	SOIC-8
MIC2514	Single	P-Channel	Yes	3V to 13.5V	400mA		2.4Ω@5V		Noninverting		Yes	Yes			SOT-23-5
MIC2536-1	Dual	N-Channel	Yes	2.7V to 5.5V	100mA		700mΩ@5V	Yes	Noninverting		Yes	Yes	Yes	Yes	SOIC-8, MSOP-8
MIC2536-2	Dual	N-Channel	Yes	2.7V to 5.5V	100mA		700mΩ@5V	Yes	Inverting		Yes	Yes	Yes	Yes	SOIC-8, MSOP-8

General Purpose Power Distribution Switch Selection Guide

Device	Type	Switch Element	Internal		Current Limit		Output Resistance	Body Diode Blocking	Enable Logic	Under			Flag		
			Charge Pump	Operating Voltage	Fixed (Min.)	Adj. (Max.)				Voltage Lockout	Current Limit	Thermal Shutdown	Fault Flag	Transient Filter	Package
MIC2537-1	Quad	N-Channel	Yes	2.7V to 5.5V	100mA		700mΩ@5V	Yes	Noninverting		Yes	Yes	Yes		SOIC-16
MIC2537-2	Quad	N-Channel	Yes	2.7V to 5.5V	100mA		700mΩ@5V	Yes	Inverting		Yes	Yes	Yes		SOIC-16
MIC2544-1	Single	N-Channel	Yes	2.7V to 5.5V	100mA	1.5A	120mΩ@5V	Yes	Noninverting		Yes	Yes	Yes		SOIC-8, MSOP-8
MIC2544-2	Single	N-Channel	Yes	2.7V to 5.5V	100mA	1.5A	120mΩ@5V	Yes	Inverting		Yes	Yes	Yes		SOIC-8, MSOP-8
MIC2545A-1	Single	N-Channel	Yes	2.7V to 5.5V	500mA	3.0A	50mΩ@5V	Yes	Noninverting		Yes	Yes	Yes		SOIC-8, PDIP-8, TSSOP-14
MIC2545A-2	Single	N-Channel	Yes	2.7V to 5.5V	500mA	3.0A	50mΩ@5V	Yes	Inverting		Yes	Yes	Yes		SOIC-8, PDIP-8, TSSOP-14
MIC2546-1	Dual	N-Channel	Yes	2.7V to 5.5V	100mA	1.5A	120mΩ@5V	Yes	Noninverting		Yes	Yes	Yes		SOIC-16, TSSOP-16
MIC2546-2	Dual	N-Channel	Yes	2.7V to 5.5V	100mA	1.5A	120mΩ@5V	Yes	Inverting		Yes	Yes	Yes		SOIC-16, TSSOP-16
MIC2546-1	Dual	N-Channel	Yes	2.7V to 5.5V	100mA	1.5A	120mΩ@5V	Yes	Noninverting		Yes	Yes	Yes		SOIC-16, TSSOP-16
MIC2546-2	Dual	N-Channel	Yes	2.7V to 5.5V	100mA	1.5A	120mΩ@5V	Yes	Inverting		Yes	Yes	Yes		SOIC-16, TSSOP-16
MIC2547-1	Dual	N-Channel	Yes	2.7V to 5.5V	100mA	1.5A	120mΩ@5V	Yes	Noninverting		Yes	Latched	Yes		SOIC-16, TSSOP-16
MIC2547-2	Dual	N-Channel	Yes	2.7V to 5.5V	100mA	1.5A	120mΩ@5V	Yes	Inverting		Yes	Latched	Yes		SOIC-16, TSSOP-16
MIC2548-1	Single	N-Channel	Yes	2.7V to 5.5V	100mA	1.5A	120mΩ@5V	Yes	Noninverting		Yes	Latched	Yes		SOIC-8, MSOP-8
MIC2548-2	Single	N-Channel	Yes	2.7V to 5.5V	100mA	1.5A	120mΩ@5V	Yes	Inverting		Yes	Latched	Yes		SOIC-8, MSOP-8
MIC2549A-1	Single	N-Channel	Yes	2.7V to 5.5V	500mA	3.0A	50mΩ@5V	Yes	Noninverting		Yes	Latched	Yes		SOIC-8, PDIP-8, TSSOP-14
MIC2549A-2	Single	N-Channel	Yes	2.7V to 5.5V	500mA	2.5A	50mΩ@5V	Yes	Inverting		Yes	Latched	Yes		SOIC-8, PDIP-8, TSSOP-14

USB Switches and USB Switches Supporting ACPI S0/S3 State Transitions⁽¹⁾

MIC2010-1	Dual	N-Channel	Yes	4.5V to 5.5V	500mA	300mA ⁽²⁾	140mΩ@5V	Yes	Noninverting	Yes	Yes	Yes	Yes	Yes	Yes	QSOP-16
MIC2010-2	Dual	N-Channel	Yes	4.5V to 5.5V	500mA	300mA ⁽²⁾	140mΩ@5V	Yes	Inverting	Yes	Yes	Yes	Yes	Yes	Yes	QSOP-16
MIC2012-1	Dual	N-Channel	Yes	4.5V to 5.5V	500mA		140mΩ@5V	Yes	Noninverting	Yes	Yes	Yes	Yes	Yes	Yes	QSOP-16
MIC2012-2	Dual	N-Channel	Yes	4.5V to 5.5V	500mA		140mΩ@5V	Yes	Inverting	Yes	Yes	Yes	Yes	Yes	Yes	QSOP-16
MIC2012	Dual	N-Channel	Yes	4.5V to 5.5V	500mA		140mΩ@5V	Yes	—	Yes	Yes	Yes	Yes	Yes	Yes	SOIC-8
MIC2070-1	Dual	N-Channel	Yes	4.5V to 5.5V	500mA	300mA ⁽²⁾	140mΩ@5V	Yes	Noninverting	Yes	Yes	Latched	Yes	Yes	Yes	QSOP-16
MIC2070-2	Dual	N-Channel	Yes	4.5V to 5.5V	500mA	300mA ⁽²⁾	140mΩ@5V	Yes	Inverting	Yes	Yes	Latched	Yes	Yes	Yes	QSOP-16
MIC2072-1	Dual	N-Channel	Yes	4.5V to 5.5V	500mA		140mΩ@5V	Yes	Noninverting	Yes	Yes	Latched	Yes	Yes	Yes	QSOP-16
MIC2072-2	Dual	N-Channel	Yes	4.5V to 5.5V	500mA		140mΩ@5V	Yes	Inverting	Yes	Yes	Latched	Yes	Yes	Yes	QSOP-16
MIC2072	Dual	N-Channel	Yes	4.5V to 5.5V	500mA		140mΩ@5V	Yes	—	Yes	Yes	Latched	Yes	Yes	Yes	SOIC-8
MIC2073 <i>New!</i>	Dual	N-Channel	Yes	2.7V to 5.5V	500mA		210mΩ@5V	Yes	Noninverting	Yes	Yes	Yes	Yes	Yes	Yes	SOIC-8
MIC2074 <i>New!</i>	Dual	N-Channel	Yes	2.7V to 5.5V	500mA		210mΩ@5V	Yes	Inverting	Yes	Yes	Yes	Yes	Yes	Yes	SOIC-8

1. Contact factory for availability of specific options. Specifications are given for "MAIN" mode operation.

2. S3 State.

USB Transceiver Selection Guide

Device	Description	Supported Speeds	Package
MIC2550A	Universal Serial Bus Transceiver	1.5Mbps (low) and 12Mbps (full)	TSSOP-14, MLF-16
MIC2551A	Universal Serial Bus Transceiver	1.5Mbps (low) and 12Mbps (full)	TSSOP-14, MLF-16
MIC2551A-2.5	Universal Serial Bus Transceiver	1.5Mbps (low) and 12Mbps (full)	MLF-14 (2.5mm x 2.5mm)
MIC2555	Universal Serial Bus On-The-Go (OTG) Transceiver	1.5Mbps (low) and 12Mbps (full)	MLF-24 (4mm x 4mm)

PC Card/PCMCIA/CardBus Power Distribution Switch Selection Guide

Micrel Advantange

- Single Chip Smallest Footprint Solution
- First Company with PCMCIA Solution

Device	Slots Supported	V _{CC3} On-Resistance	V _{CC5} On-Resistance	V _{PP} On-Resistance	Current Limit	Thermal Shutdown	Charge Pump ⁽¹⁾	Package
MIC2560	Single	40mΩ	70mΩ	550mΩ	Yes	Yes		WSOIC-16
MIC2561	Single	110mΩ	210mΩ	550mΩ	Yes	Yes		SOIC-14
MIC2562A	Single	100mΩ	70mΩ	600mΩ	Yes	Yes	Yes	SOIC-14
MIC2563A	Dual	100mΩ	70mΩ	600mΩ	Yes	Yes	Yes	SSOP-28
MIC2564A	Dual	120mΩ	85mΩ	1300mΩ	Yes	Yes	Yes	SSOP-24, TSSOP-24
MIC2566	Single	120mΩ	85mΩ	—	Yes	Yes	Yes	SOIC-14, TSSOP-14
MIC2568	Dual	120mΩ	85mΩ	—	Yes	Yes	Yes	SSOP-28, TSSOP-28
MIC2569		90mΩ	—	275mΩ	Yes	Yes	Yes	QSOP-16

1. 12V is not required for switching when equipped with a charge pump.

Operational Amplifier Selection Guide

Micrel Advantange

- Low Power
- Low Current
- Can Drive Large Capacitance Loads
- Best Performance

Device	Description	GBW	Slew Rate	Supply Current (per Op Amp)	Input Offset Voltage (max.)	Input Bias Current	Supply Range	Rail-to-Rail I/O	# of Op Amps Per Package	Package	Comments
MIC6211	High-Voltage Op Amp	2.5MHz	6V/μs	1.2mA	7mV	50nA	4V–32V		1	SOT-23-5	High-Voltage General Purpose.
LMC7101	General Purpose Op Amp	500kHz	0.5V/μs	500μA	6mV	1pA	2.7V–10V	Input/Output	1	SOT-23-5	Rail-to-Rail Input and Output.
MIC7111	Micropower 1.8V Op Amp	25kHz	20mV/μs	15μA	7mV	1pA	1.8V–11V	Input/Output	1	SOT-23-5	Rail-to-Rail Input and Output.
MIC7122	Rail-to-Rail Dual Op Amp	750kHz	0.7V/μs	350μA	9mV	1pA	2.2V–15V	Input/Output	2	MSOP-8	Rail-to-Rail Input and Output.
MIC7300	High Output Drive Op Amp	500kHz	0.5V/μs	700μA	9mV	0.5pA	2.2V–10V	Input/Output	1	SOT-23-5 MSOP-8	Rail-to-Rail Input and Output.
MIC860	4MHz/30μA Op Amp	4MHz	3V/μs	30μA	15mV	20pA	2.43V–5.25V	Output	1	SC-70-5	Very Low Power.
MIC861	400kHz/4.6μA Op Amp	400kHz	0.12V/μs	4.6μA	10mV	20pA	2.43V–5.25V	Output	1	SC-70-5	Very Low Power.
MIC862	Dual 3MHz/31μA Op Amp	3MHz	4V/μs	31μA	6mV	10pA	2V–5.25V	Output	2	SOT-23-8	Very Low Power.
MIC863	Dual 450KHz/4.2μA Op Amp	450KHz	0.35V/μs	4.2μA	6mV	10pA	2V–5.25V	Output	2	SOT-23-8	Very Low Power.
MIC910	135MHz Op Amp	135MHz	270V/μs	2.4mA	15mV	3.5μA	5V–18V		1	SOT-23-5	Low Power/High Speed.
MIC911	105MHz Op Amp	105MHz	120V/μs	1.25mA	10mV	1.5μA	5V–18V		1	SOT-23-5	Low Power/High Speed.
MIC912	200MHz Op Amp	200MHz	360V/μs	2.4mA	15mV	3.5μA	5V–18V		1	SOT-23-5	Low Power/High Speed.
MIC913	350MHz Op Amp	350MHz	500V/μs	4.2mA	16mV	5.5μA	5V–18V		1	SOT-23-5	Low Power/High Speed.
MIC914	160MHz Op Amp	160MHz	160V/μs	1.25mA	10mV	1.5μA	5V–18V		1	SOT-23-5	Low Power/High Speed.
MIC915	Dual MIC910	135MHz	270V/μs	2.4mA	15mV	3.5μA	5V–18V		2	MSOP-10	Low Power/High Speed.
MIC916	Triple MIC910	135MHz	270V/μs	2.4mA	15mV	3.5μA	5V–18V		3	QSOP-8	Low Power/High Speed.
MIC918	1500V/μs Op Amp	51MHz	1500V/μs	550μA	5mV	0.26μA	5V–18V		1	SC-70-5	Low Power/High Speed.
MIC919	1500V/μs Op Amp	27MHz	1500V/μs	360μA	5mV	0.13μA	5V–18V		1	SC-70-5	Low Power/High Speed.
MIC920	3000V/μs Op Amp	80MHz	3000V/μs	500μA	5mV	0.26μA	5V–18V		1	SC-70-5	Low Power/High Speed.
MIC921	3000V/μs Op Amp	45MHz	3000V/μs	300μA	5mV	0.13μA	5V–18V		1	SC-70-5	Low Power/High Speed.
MIC922	230MHz Op Amp	230MHz	1500V/μs	2.5mA	5mV	1.7μA	5V–18V		1	SC-70-5	Low Power/High Speed.
MIC923	410MHz/2200V/μs Op Amp	410MHz	2200V/μs	2.5mA	5mV	1.7μA	5V–18V		1	SC-70-5	Low Power/High Speed.

Comparator Selection Guide

Device	Description	Response Time	Supply Current	Input Offset Voltage (max.)	Input Bias Current	Supply Range	Package	Comments
MIC6270	High-Voltage Comparator	600ns	0.3mA	5mV	25nA	2V–36V	5-Pin SOT-23	
MIC7211	Rail-to-Rail Input Comparator	4μs	5μA	10mV	5pA	2.2V–10V	5-Pin SOT-23	Push-Pull Output.
MIC7221	Rail-to-Rail Input Comparator	4μs	5μA	10mV	5pA	2.2V–10V	5-Pin SOT-23	Open-Drain Output.
MIC833	Comparator and Reference w/Adjustable Hysteresis	5μs	1μA	n/a	5pA	1.5V–5.5V	5-Pin SOT-23	Internal 1% Reference.
MIC834	Comparator and Reference	5μs	1.5μA	n/a	5pA	1.5V–5.5V	5-Pin SOT-23	Internal 1% Reference.
MIC841	Comparator and Reference w/Adjustable Hysteresis	12μs	1.5μA	n/a	5pA	1.5V–5.5V	5-Pin SC-70	Internal 1.25% Reference.
MIC842	Comparator and Reference	12μs	1.5μA	n/a	5pA	1.5V–5.5V	5-Pin SC-70	Internal 1.25% Reference.
MIC845	Micro-Power Comparator Battery Monitor	12μs	1.0μA	n/a	5pA	2.75V–5.5V	5-Pin SC-70	Internal 2% Reference, 2.55V Reference.

MOSFET Driver Selection Guide

Device	Function	Type	Logic	Sink/Source Peak Output	Sink/Source Output Impedance	t_r/t_f	t_{pd} (input rise/fall)	Supply Voltage	Package	Comments
Half-Bridge Drivers										
MIC4100	Half-Bridge MOSFET Driver	Dual	Non-Inverting (CMOS)	2A/2A	2.5Ω/2.5Ω	10ns into 1000pF	27ns into 1,000pF	up to 100V	SOIC-8, MLF-8 (3mm x 3mm) ⁽¹⁾	Hysteresis on input pins for noisy or slow signals.
MIC4101	Half-Bridge MOSFET Driver	Dual	Non-Inverting (TTL)	2A/2A	2.5Ω/2.5Ω	10ns into 1000pF	27ns into 1,000pF	up to 100V	SOIC-8, MLF-8 (3mm x 3mm) ⁽¹⁾	Level shift between V_{IN} signal and V_{DD} supply voltage.
MIC4102	High-Voltage Sync. Buck Driver	Dual	Non-Inverting (TTL)	3A/2A	1.5Ω/2.5Ω	10ns/6ns into 1000pF	27ns into 1,000pF	up to 100V	SOIC-8, MLF-8 (3mm x 3mm) ⁽¹⁾	Embedded Anti-Shoot through Protection.
MIC4103	Half-Bridge MOSFET Driver	Dual	Non-Inverting (CMOS)	3A/2A	1.25Ω/2.5Ω	10ns/6ns into 1000pF	27ns into 1,000pF	up to 100V	SOIC-8, MLF-8 (3mm x 3mm) ⁽¹⁾	
MIC4104	Half-Bridge MOSFET Driver	Dual	Non-Inverting (TTL)	3A/2A	1.25Ω/2.5Ω	10ns/6ns into 1000pF	27ns into 1,000pF	up to 100V	SOIC-8, MLF-8 (3mm x 3mm) ⁽¹⁾	
Low-Side Drivers										
MIC4120 ⁽²⁾	Low-Side Driver	Single	Non-Inverting	6A	1.5Ω	12ns/13ns into 2500pF	45ns/50ns into 2,500pF	4.5V to 20V	eSOIC-8, MLF-8 (3mm x 3mm)	MIC4420 upgrade; Advanced packaging; Higher input voltage; Input pulse down to 50ns.
MIC4123 ⁽²⁾	Low-Side Driver	Dual	Inverting	3A	2.2Ω	23ns/25ns into 1800pF	44ns/59ns into 1,800pF	4.5V to 20V	eSOIC-8, MLF-8 (4mm x 4mm)	MIC4423 upgrade; Advanced packaging; Higher input voltage; Input pulse down to 50ns.
MIC4124 ⁽²⁾	Low-Side Driver	Dual	Non-Inverting	3A	2.2Ω	23ns/25ns into 1800pF	44ns/59ns into 1,800pF	4.5V to 20V	eSOIC-8, MLF-8 (4mm x 4mm)	MIC4424 upgrade; Advanced packaging; Higher input voltage; Input pulse down to 50ns.
MIC4125 ⁽²⁾	Low-Side Driver	Dual	Inverting + Non-Inverting	3A	2.2Ω	23ns/25ns into 1800pF	44ns/59ns into 1,800pF	4.5V to 20V	eSOIC-8, MLF-8 (4mm x 4mm)	MIC4425 upgrade; Advanced packaging; Higher input voltage; Input pulse down to 50ns.
MIC4126 ⁽²⁾	Low-Side Driver	Dual	Inverting	1.5A	6Ω	13ns/15ns into 1000pF	37ns/40ns into 1000pF	4.5V to 20V	eSOIC-8, eMSOP-8, MLF-8 (3mm x 3mm)	MIC4426 upgrade; Advanced packaging; Higher input voltage; Input pulse down to 50ns.
MIC4127 ⁽²⁾	Low-Side Driver	Dual	Non-Inverting	1.5A	6Ω	13ns/15ns into 1000pF	37ns/40ns into 1000pF	4.5V to 20V	eSOIC-8, eMSOP-8, MLF-8 (3mm x 3mm)	MIC4427 upgrade; Advanced packaging; Higher input voltage; Input pulse down to 50ns.
MIC4128 ⁽²⁾	Low-Side Driver	Dual	Inverting + Non-Inverting	1.5A	6Ω	13ns/15ns into 1000pF	37ns/40ns into 1000pF	4.5V to 20V	eSOIC-8, eMSOP-8, MLF-8 (3mm x 3mm)	MIC4428 upgrade; Advanced packaging; Higher input voltage; Input pulsedown to 50ns.
MIC4129 ⁽²⁾	Low-Side Driver	Single	Inverting	6A	1.5Ω	12ns/13ns into 2500pF	45ns/50ns into 2,500pF	4.5V to 20V	eSOIC-8, MLF-8 (3mm x 3mm)	MIC4429 upgrade; Advanced packaging; Higher input voltage; Input pulse down to 50ns.
MIC4416	Low-Side Driver	Single	Non-Inverting	1.2A	7.6Ω/7.8Ω	24ns/28ns into 1000pF	42ns into 1,000pF	4.5V to 18V	SOT-143	IttyBitty® Device.
MIC4417	Low-Side Driver	Single	Inverting	1.2A	7.6Ω/7.8Ω	24ns/28ns into 1000pF	37ns into 1,000pF	4.5V to 18V	SOT-143	IttyBitty® Device.
MIC44F18	N-Channel MOSFET Driver	Single	Non-Inverting (TTL)	6A	2Ω	10ns/10ns into 1000pF	15ns/13ns into 1000pF	4.5V to 13.2V	MLF-8 (2mm x 2mm), eMSOP-8,	High Speed; small, thermally efficient package.
MIC44F19	P-Channel MOSFET Driver	Single	Inverting (TTL)	6A	2Ω	10ns/10ns into 1000pF	15ns/13ns into 1000pF	4.5V to 13.2V	MLF-8 (2mm x 2mm), eMSOP-8,	High Speed; small, thermally efficient package.
MIC44F20	N-Channel MOSFET Driver	Single	Inverting (TTL)	6A	2Ω	10ns/10ns into 1000pF	15ns/13ns into 1000pF	4.5V to 13.2V	MLF-8 (2mm x 2mm), eMSOP-8	High Speed; small, thermally efficient package.
MIC4420	Low-Side Driver	Single	Non-Inverting	6A	1.7Ω/1.5Ω	12ns/13ns into 2500pF	18ns/48ns into 2500pF	4.5V to 18V	SOIC-8, MSOP-8, PDIP-8, TO-220-5, CerDIP-8 ⁽³⁾	Drives Hex 6–Hex 7 Size. MOSFET: 1,500pF to 16,000pF; Latch-Up Protected; Input to –5V.
MIC4429	Low-Side Driver	Single	Inverting	6A	1.7Ω/1.5Ω	12ns/13ns into 2500pF	18ns/48ns into 2500pF	4.5V to 18V	SOIC-8, MSOP-8, PDIP-8, TO-220-5,	Drives a Hex 6–Hex 7 Size. MOSFET: 1,500pF to 16,000pF; Latch-Up Protected; Input to –5V.
MIC4421 MIC4421A ⁽²⁾	Low-Side Driver	Single	Inverting	9A	0.8Ω/0.6Ω	20ns/24ns into 10nF	15ns/35ns into 10nF	4.5V to 18V	PDIP-8, SOIC-8, TO-220-5	Drives 1,500pF to 47,000pF; Latch-Up Protected; Input to –5V.
MIC4422 MIC4422A ⁽²⁾	Low-Side Driver	Single	Non-inverting	9A	0.8Ω/0.6Ω	20ns/24ns into 10nF	15ns/35ns into 10nF	4.5V to 18V	PDIP-8, SOIC-8, TO-220-5	Drives 1,500pF to 47,000pF; Latch-Up Protected; Input to –5V.

1. Contact factory for MLF[®] availability.
2. Recommended for new designs.
3. SMD (military) 5962-8877003PA.

MOSFET Driver Selection Guide

Device	Function	Type	Logic	Sink/Source	Sink/Source	t_r/t_f	t_{pd} (input rise/fall)	Supply Voltage	Package	Comments
				Peak Output	Output Impedance					
MIC4423	Low-Side Driver	Dual	Inverting	3A	3.8Ω/3.5Ω	23ns/25ns into 1800pF	33ns/38ns into 1800pF	4.5V to 18V	SOIC-8, WSOIC-16, PDIP-8	Drives Hex 4–Hex 5 Size. MOSFET: 6,000pF to 12,000pF; Latch-Up Protected; Input to –5V.
MIC4424	Low-Side Driver	Dual	Non-inverting	3A	3.8Ω/3.5Ω	23ns/25ns into 1800pF	33ns/38ns into 1800pF	4.5V to 18V	SOIC-8, WSOIC-16, PDIP-8, CerDIP-8 ⁽⁵⁾	Drives a Hex 4–Hex 5 Size. MOSFET: 6,000pF to 12,000pF; Latch-up Protected; Input to –5V.
MIC4425	Low-Side Driver	Dual	Inverting + Non-Inverting	3A	3.8Ω/3.5Ω	23ns/25ns into 1800pF	33ns/38ns into 1800pF	4.5V to 18V	SOIC-8, -16 PDIP-8	Drives a Hex 4–Hex 5 Size. MOSFET: 6,000pF to 12,000pF; Latch-up Protected; Input to –5V.
MIC4426	Low-Side Driver	Dual	Inverting	1.5A	6Ω	18ns/15ns into 1000pF	17ns/23ns into 1000pF	4.5V to 18V	SOIC-8, MSOP-8, PDIP-8 CerDIP-8 ⁽⁶⁾	Drives a Hex 0–Hex 3 Size. MOSFET: 400pF to 3,000pF; Latch-up Protected; Input to –5V.
MIC4427	Low-Side Driver	Dual	Non-inverting	1.5A	6Ω	18ns/15ns into 1000pF	17ns/23ns into 1000pF	4.5V to 18V	SOIC-8, MSOP-8, PDIP-8V CerDIP-8 ⁽⁷⁾	Drives a Hex 0–Hex 3 Size. MOSFET: 400pF to 3,000pF; Latch-up Protected; Input to –5V.
MIC4428	Low-Side Driver	Dual	Inverting + Non-Inverting	1.5A	6Ω	18ns/15ns into 1000pF	17ns/23ns into 1000pF	4.5V to 18V	SOIC-8, MSOP-8, PDIP-8 CerDIP-8 ⁽⁸⁾	Drives a Hex 0–Hex 3 Size. MOSFET: 400pF to 3,000pF; Latch-up Protected; Input to –5V.
MIC4451 MIC4451A ⁽⁴⁾	Low-Side Driver	Single	Inverting	12A	0.8Ω/0.6Ω	20ns/24ns into 15nF	15ns/35ns into 15nF	4.5V to 18V	SOIC-8, PDIP-8, TO-220-5	Drives 1,500pF to 62,000pF; Latch-up Protected; Input to –5V.
MIC4452 MIC4452A ⁽⁴⁾	Low-Side Driver	Single	Non-inverting	12A	0.8Ω/0.6Ω	20ns/24ns into 15nF	15ns/35ns into 15nF	4.5V to 18V	SOIC-8, PDIP-8, TO-220-5	Drives 1,500pF to 62,000pF; Latch-up Protected; Input to –5V.
MIC4467	Low-Side Driver	Quad	Non-inverting NAND Inputs	1.2A	5Ω	14ns/13ns into 470pF	30ns/45ns into 470pF	4.5V to 18V	WSOIC-16, PDIP-14	Drives a Hex 0–Hex 3 Size. MOSFET: 400pF to 3,000pF; Latch-up Protected; Input to –5V.
MIC4468	Low-Side Driver	Quad	Non-inverting AND Inputs	1.2A	5Ω	14ns/13ns into 470pF	30ns/45ns into 470pF	4.5V to 18V	WSOIC-16, PDIP-14	Drives a Hex 0–Hex 3 Size. MOSFET: 400pF to 3,000pF; Latch-up Protected; Input to –5V.
MIC4469	Low-Side Driver	Quad	Inverting + Non-inverting AND Inputs	1.2A	5Ω	14ns/13ns into 470pF	30ns/45ns into 470pF	4.5V to 18V	WSOIC-16, PDIP-14 CerDIP-14 ⁽⁹⁾	Drives a Hex 0–Hex 3 Size. MOSFET: 400pF to 3,000pF; Latch-up Protected; Input to –5V.
MIC5011	High- or Low-Side Driver	Single	Non-inverting	–	–	60μs into 1,000pF		4.75V to 32V	SOIC-8, PDIP-8	External Charge Pump. Capacitors (opt.).
MIC5013	High- or Low-Side Driver	Single	Non-inverting	–	–	60μs into 1,000pF		7V to 32V	SOIC-8, PDIP-8	Current Sense, Fault.
MIC5014	High- or Low-Side Driver	Single	Non-inverting	–	–	90μs into 1,000pF		2.75V to 30V	SOIC-8, PDIP-8	
MIC5015	High- or Low-Side Driver	Single	Inverting	–	–	90μs into 1,000pF		2.75V to 30V	SOIC-8, PDIP-8	
MIC5016 ⁽¹⁰⁾	High- or Low-Side Driver	Dual	Non-inverting	–	–	90μs into 1,000pF		2.75V to 30V	WSOIC-16, PDIP-14	
MIC5017 ⁽¹⁰⁾	High- or Low-Side Driver	Dual	Inverting	–	–	90μs into 1,000pF		2.75V to 30V	WSOIC-16, PDIP-14	
MIC5018	High- or Low-Side Driver	Single	Non-inverting	–	–	2.1ms into 3,000pF		2.7V to 9V	SOT-143	IttyBitty [®] Device.
MIC5020	Complementary Low-Side Driver	Single	Non-inverting	–	–	1.1μs into 1,500pF		11V to 50V	SOIC-8	Complement to MIC5021 (Similar Performance), Current Sense (50mV nominal).
MIC5021	High-Speed High-Side Driver	Single	Non-inverting	–	–	0.9μs into 1,500pF		12V to 36V	SOIC-8, PDIP-8	Current Sense (50mV nominal).

4. Recommended for new designs.

5. SMD (military) 5962-8850305PA.

6. SMD (military) 5962-8850307PA.

7. SMD (military) 5962-8850308PA.

8. SMD (military) 5962-8850309PA.

9. SMD (military) 5962-9459403MCA.

10. Product family discontinuance announced effective June 3, 2005. Recommended Micrel alternatives; two each MIC5014 and two each MIC5015.

Voltage Monitors and Voltage/Processor Supervisors Selection Guide

Micrel Advantange

- Industry Standards
- Cross to Maxim
- Very Low IQ
- Very Low Supply Voltage
- Adjustable Hysterisis

Standard Voltage Supervisors

Device	Manual Reset Input	Reset Output Polarity	Reset Threshold Voltage	t _{RESET} (ms)	I _{SUPPLY} (μA)	Package
MIC1810-15/-10/-5	No	Low	4.12V, 4.37V, 4.62V	100	9.0	SOT-23-3
MIC1815-20/-10	No	Low	2.55V, 2.88V	100	9.0	SOT-23-3
MIC809R/S/T/J/M/L	No	Low	2.63V, 2.93V, 3.08V, 4.00V, 4.38V, 4.63V	140	9.0	SOT-23-3, SC-70-5
MIC810R/S/T/J/M/L	No	High	2.63V, 2.93V, 3.08V, 4.00V, 4.38V, 4.63V	140	9.0	SOT-23-3, SC-70-5
MIC811R/S/T/J/M/L	Yes	Low	2.63V, 2.93V, 3.08V, 4.00V, 4.38V, 4.63V	140	9.0	SOT-143
MIC812R/S/T/J/M/L	Yes	High	2.63V, 2.93V, 3.08V, 4.00V, 4.38V, 4.63V	140	9.0	SOT-143
MIC6315-xxD2	Yes	Low	2.5-5.0V in 100mV increments	20	9.0	SOT-143
MIC6315-xxD3	Yes	Low	2.5-5.0V in 100mV increments	140	9.0	SOT-143
MIC6315-xxD4	Yes	Low	2.5-5.0V in 100mV increments	1100	9.0	SOT-143
MIC707	Yes	Both	4.65V	140	60	SOIC-8, PDIP-8
MIC708	Yes	Both	4.40V	140	60	SOIC-8, PDIP-8
MIC708R/S/T	Yes	Both	2.63V, 2.93V, 3.08V	140	30	SOIC-8, PDIP-8

Microprocessor Supervisors with Watchdog Timers

Device	Manual Reset Input	Reset Output(s) Polarity	Reset Threshold Voltage	Watchdog Timeout	Power Fail Detect	t _{RESET} (ms)	I _{SUPPLY} (μA)	Package
MIC705	Yes	Low	4.65V	1.6s	Yes	140	60	SOIC-8, PDIP-8
MIC706	Yes	Low	4.40V	1.6s	Yes	140	60	SOIC-8, PDIP-8
MIC706P	Yes	High	2.63V	1.6s	Yes	140	30	SOIC-8, PDIP-8
MIC706R/S/T	Yes	Low	2.63V, 2.93V, 3.08V	1.6s	Yes	140	30	SOIC-8, PDIP-8
MIC1232	Yes	Both	4.62V or 4.37V	150ms/600ms/1.2s	Yes	250	30	SOIC-8, PDIP-8
MIC1832	Yes	Both	2.88V or 2.55V	150ms/600ms/1.2s	Yes	250	30	8-Pin SOIC, 8-Pin PDIP

Standard Voltage Supervisors for AMD Elan™ Microprocessors

Device	Manual Reset Input	Reset Output Polarity	Reset Threshold Voltage	t _{RESET} (ms)	I _{SUPPLY} (μA)	Package
MIC8114T (SC400/410)	Yes	Low	3.08V	790	9.0	SOT-143
MIC8115T (SC500)	Yes	Low	3.08V	1100	9.0	SOT-143

Single and Dual Ultra-Low Voltage Supervisors

Device	Single/Dual	Manual Reset Input	Reset Output(s) Polarity	Reset Threshold Voltage	t _{RESET} (ms)	I _{SUPPLY} (μA)	Package
MIC2772-xxxxYM5	Dual	Yes	Low	2.93V, 3.08V, 4.38V, 4.63V	140	10	MLF-8
MIC2774H-xxYM5	Dual	Yes	High	Fixed: 1.69V, 2.25V, 2.34V, 2.53V, 2.67V, 2.81V,	140	3.5	SOT-23-5
MIC2774N-xxYM5			Open-Drain	2.93V, 3.09V, 4.43V, 4.68V;			
MIC2774L-xxYM5			Low	Adjustable from 0.300V min.			
MIC2775-xxYM5	Single	Yes	Both	1.69V, 2.25V, 2.34V, 2.53V, 2.67V, 2.81V, 2.93V, 3.09V, 4.43V, 4.68V	140	3.5	SOT-23-5V
MIC2776N-YM5	Single	Yes	Open-Drain	Adjustable from 0.300V min.	140	3.5	SOT-23-5
MIC2776L-YM5	Single	Yes	Low	Adjustable from 0.300V min.	140	3.5	SOT-23-5
MIC2776H-YM5	Single	Yes	High	Adjustable from 0.300V min.	140	3.5	SOT-23-5
MIC2777-xxYM5	Dual	Yes ⁽¹⁾	Both	Fixed: 1.69V, 2.25V, 2.34V, 2.53V, 2.67V, 2.81V, 2.93V, 3.09V, 4.43V, 4.68V; Adjustable from 0.300V min.	140	3.5	SOT-23-5

1. Manual reset switch connects to adjustable input.

Voltage Monitors and Voltage/Processor Supervisors Selection Guide

Voltage Monitors and Supervisors Optimized for Battery Monitoring

Device	Manual Reset Input	Reset Output(s) Polarity	V _{RESET}	Adjustable Hysteresis	t _{RESET} (ms)	I _{SUPPLY} (μA)	Package
MIC833	No	High	Adjustable ≥ 1.25V	Y	n/a	1.0	SOT-23-5
MIC834	No	High	Adjustable ≥ 1.25V	N	n/a	1.5	SOT-23-5
MIC841	No	High or Low	Adjustable ≥ 1.25V	Y	n/a	1.5	SC-70-5
MIC842	No	High or Low	Adjustable ≥ 1.25V	N	n/a	1.5	SC-70-5
MIC845	n/a	High or Low	2.55V or adjustable >2.55V	N	n/a	1.0	SC-70-5
MIC2755	Yes	Open-Drain	Adjustable ≥ 1.25V	Y	700	2.0	MSOP-8
MIC2778-1/-2 ⁽¹⁾	No	Low	Adjustable ≥ 1.25V	Y	140	1.0	SOT-23-5
MIC2779L-1/-2 ⁽¹⁾	No	Low	Adjustable ≥ 1.25V	Y	140	1.0	SOT-23-5
MIC2779H-1/-2 ⁽¹⁾	No	High	Adjustable ≥ 1.25V	Y	140	1.0	SOT-23-5

1. -1 is 1% and -2 is 2% 1.25V reference tolerance.

Thermal/System Management, Transistors and Arrays, Timers, References, and SCSI Terminators Selection Guides

Micrel Advantange

- General Purpose Flexible Design

2-Wire Serial Thermal Supervisors

Device	Description	Remote Zone	Internal Zone	Data Width	CRIT Output	Device Bus	Resolution (Bits)	Accuracy	Package
MIC184	Local/Remote Thermal Supervisor	1 ⁽¹⁾	Yes	9	—	8 ⁽²⁾	9	3%	SOIC-8, MSOP-8
MIC280	Precision IttyBitty® Thermal Supervisor	1	Yes	12	Yes	8	12	1%	SOT-23-6
MIC281	Low-Cost IttyBitty® Thermal Sensor	1	—	8	—	8	8	3%	SOT-23-6
MIC284	2-Zone Thermal Supervisor w/CRIT Output	1	Yes	8	Yes	8	8	3%	SOIC-8, MSOP-8
MIC384	3-Zone Thermal Supervisor	2	Yes	8	—	8	8	3%	SOIC-8, MSOP-8

1. MIC184 has limit registers for monitoring one zone at a time; either the internal or external zone may be monitored at any given time.

2. In LM75 mode; 4 when using T1 function.

Fan Management ICs

Device	Description	Package
MIC502	Fan Management IC	PDIP-8, SOIC-8
MIC74	2-Wire Serial I/O Expander and Fan Controller	QSOP-16

I/O Expanders

Device	Description	Package
MIC74	2-Wire Serial I/O Expander and Fan Controller	QSOP-16

Transistors/Switches

Device	Description	Voltage Range	On-Resistance	Substrate Pin	Gate Pull-Up Resistor	Package
MIC94030	Single P-Channel MOSFET	2.7V to 13.5V	0.75Ω @ V _{GS} = 4.5V	Yes	—	SOT-143-4
MIC94031	Single P-Channel MOSFET	2.7V to 13.5V	0.75Ω @ V _{GS} = 4.5V	Yes	Yes	SOT-143-4
MIC94050	Single P-Channel MOSFET	1.8V to 5.5V	0.125Ω @ V _{GS} = 4.5V	Yes	—	SOT-143
MIC94051	Single P-Channel MOSFET	1.8V to 5.5V	0.125Ω @ V _{GS} = 4.5V	Yes	Yes	SOT-143
MIC94052	Single P-Channel MOSFET	1.8V to 5.5V	0.07Ω @ V _{GS} = 4.5V	—	—	SC-70-6
MIC94053	Single P-Channel MOSFET	1.8V to 5.5V	0.07Ω @ V _{GS} = 4.5V	—	Yes	SC-70-6

Array

Device	Description	Voltage	Input Signal	Package
MIC2981/82	Octal Source-Driver Array	50V	5V-TTL or 5V-to-15V CMOS or PMOS	PDIP-18, WSOIC-18

Timers

Device	Description	Package
MIC1555	IttyBitty® RC Timer/Oscillator	SOT-23-5
MIC1557	IttyBitty® RC Oscillator	SOT-23-5

References

Device	Description	Package
LM4040/4041	Precision Micropower Shunt Voltage Reference	SOT-23-3

Hot Swap Power Controller Selection Guide

Micrel Advantange

- Robustness
- High voltage capability
- Superior parametric performance
- Smallest solution size

Device	Outputs	Input Voltage Range	Latch Off	Auto Retry	/FAULT	/POR	PWRGD or RST	OV SCR	Foldback Current Limit	Packages	Comments
MIC2085	1	+2.3V to +16.5V	Yes		Yes	Yes		Yes	Yes	QSOP-16	Pin-for-pin equivalent to LTC1642; Uncommitted comparator and crowbar output.
MIC2086	1	+2.3V to +16.5V	Yes		Yes	Yes	/PWRGD	Yes	Yes	QSOP-20	Uncommitted comparator, crowbar output, and C _L discharge capability.
MIC2580A	4	±12V, +3.3V, +5V	Yes		Yes	Yes	/PWRGD		Yes	TSSOP-24	Single-slot controller for CompactPCI applications.
MIC2582	1	+2.3V to +13.2V	Yes			Yes				SOIC-8	Pin-for-pin functional equivalent to LTC1422; Dual-level fault detection.
MIC2583	1	+2.3V to +13.2V	Yes		Yes	Yes	PWRGD			QSOP-16	Dual-level fault detection; C _L discharge capability.
MIC2583R	1	+2.3V to +13.2V		Yes	Yes	Yes	PWRGD			QSOP-16	Dual-level fault detection; C _L discharge capability.
MIC2310-1 MIC2310-2	1	+10.8V to +13.2V	Yes	Yes	HW_FLT, I_FLT HW_FLT, I_FLT		PWRGD /PWRGD			TSSOP-24	Single FET, constant power-limit, Hot plug controller for general purpose power-limiting applications and UL60950 systems (240-VA).
MIC2584	2	CH1: +2.3V to +13.2V CH2: +1V to +13.2V	Yes		Yes	Yes				TSSOP-16	Output voltage tracking with dual-level fault detection.
MIC2585-1 MIC2585-2	2 2	CH1: +2.3V to +13.2V CH2: +1V to +13.2V	Yes		Yes	Yes	PWRGD			TSSOP-24	V _{OUT} sequencing/tracking with dual-level detection and C _L discharge capability: -1: V _{OUT2} follows V _{OUT1} ; -2: V _{OUT1} follows V _{OUT2} .
MIC2590B	10	±12V, +5V, +3.3V, and +3.3V _{AUX}	Yes		Yes					TQFP-48	Dual-slot controller for PCI v2.x and PCI-X 1.0b. Compliant applications with IPMI v1.0 support.
MIC2593	10	±12V, +5V, +3.3V, and +3.3V _{AUX}	Yes		Yes					TQFP-48	Dual-slot controller for PCI v2.x and PCI-X 1.0b. Compliant applications without IPMI v1.0 support.
MIC2341 MIC2341R	6	+12V, +3.3V, and +3.3V _{AUX}	Yes	Yes	Yes		/PWRGD /DLY_PWRGD			TQFP-48	Dual-slot controller for PCI-Express systems without the SMBus interface (hardware mode only); MAIN & AUX outputs are independent.
MIC2342 MIC2342R	6	+12V, +3.3V, and +3.3V _{AUX}	Yes	Yes	Yes		/PWRGD /DLY_PWRGD			TQFP-48	Dual-slot controller for PCI-Express systems without the SMBus interface (hardware mode only); MAIN & AUX outputs are inter-dependent upon AUX overcurrent event.
MIC2591B	6	+12V, +3.3V, and +3.3V _{AUX}	Yes		Yes		/PWRGD			TQFP-48	Dual-slot controller for PCI-Express systems with IPMI v1.0 support.
MIC2592B	6	+12V, +3.3V, and +3.3V _{AUX}	Yes		Yes		/PWRGD			TQFP-48	Dual-slot controller for PCI-Express systems where IPMI v1.0 support not needed.
MIC2586-1 MIC2586-2	1	+10V to +80V	Yes				PWRGD /PWRGD		Yes	SOIC-14	Multiple PWRGD outputs for sequencing, user-programmable delay.
MIC2586R-1 MIC2586R-2	1	+10V to +80V		Yes			PWRGD /PWRGD		Yes	SOIC-14	Multiple PWRGD outputs for sequencing, user-programmable delay.
MIC2587-1 MIC2587-2	1	+10V to +80V	Yes				PWRGD /PWRGD		Yes	SOIC-8	1st Generation +48V controller. Pin-for-pin equivalent to LT1641-1.
MIC2587R-1 MIC2587R-2	1	+10V to +80V		Yes			PWRGD /PWRGD		Yes	SOIC-8	1st Generation +48V controller. Fault condition: Auto-retry. Pin-for-pin equivalent to LT1641-2.
MIC2588-1 MIC2588-2	1	-19V to -80V	Yes				PWRGD /PWRGD			SOIC-8	1st Generation -48V controller; pin-for-pin equivalent to LT1640/LT1640A/LT4250.
MIC2594-1 MIC2594-2	1	-19V to -80V	Yes				PWRGD /PWRGD			SOIC-8	MIC2588 with Programmable input ON/OFF control.
MIC2589-1 MIC2589-2	1	-19V to -80V	Yes				PWRGD /PWRGD			SOIC-14	Programmable UVLO and OV protection and three PWRGD outputs for sequencing.
MIC2589R-1 MIC2589R-2	1	-19V to -80V		Yes			PWRGD /PWRGD			SOIC-14	Programmable UVLO and OV protection and three PWRGD outputs for sequencing.
MIC2595-1 MIC2595-2	1	-19V to -80V	Yes				PWRGD /PWRGD			SOIC-14	Programmable input ON/OFF control and three PWRGD outputs for sequencing.
MIC2595R-1 MIC2595R-2	1	-19V to -80V		Yes			PWRGD /PWRGD			SOIC-14	Programmable input ON/OFF control and three PWRGD outputs for sequencing.

RF Remote Packet Generator

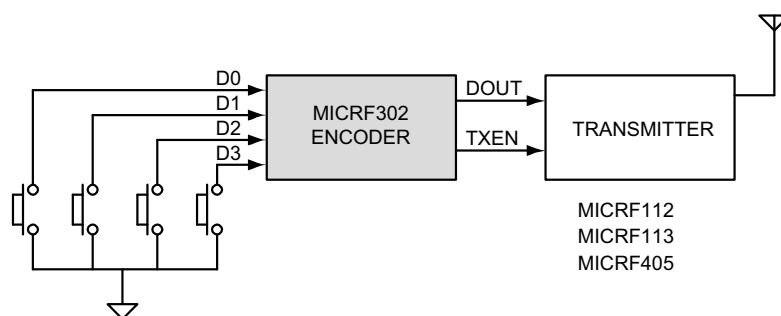

MICRF302 Block Diagram

The MICRF302 RF remote packet generator translates push-button closures into Manchester encoded packets greatly simplifying design and reducing the need for a costly microcontroller in cost-sensitive one-way transmitter applications such as RKE, Garage Door Openers and Remote Controls. The MICRF302 is designed to easily connect to Micrel's family of low-power, low-cost, 300MHz to 1GHz, ASK or FSK RF transmitters, such as the MICRF112, MICRF113 or MICRF405. Each MICRF302 contains a 20-bit Poly-Fuse Programmable Read-Only Memory (PPROM) which is programmed at the factory and offers over 1 Million unique addresses. A pair of logic-level inputs allows the device to be set to support data rates of 0.6, 1.0, 3.0 or 4.8kbps. The internal clock requires no external components and maintains an accuracy of $\pm 10\%$. Four logic-level input pins support 1 to 15 external switches. Upon any switch closure, the device is immediately awoken from Standby Mode, a TX enable signal is sent to awake the accompanying transmitter, and a Manchester encoded packet is generated. Each packet includes a pre-amble, sync, address, data and an 8-bit Cyclic Redundancy Check (CRC) which allows the decoder to check for errors in the packet. Each packet is transmitted four times to improve the probability of a received signal. After transmission the device is immediately placed in low-power standby mode. The MICRF302 consumes 0.3uA in standby mode and 130uA during operation from a 1.8V to 3.6V power supply.

Features

- Factory programmed 20-bit address with >1M unique addresses
- 4 push-button switch inputs supports 1 to 15 switches
- Manchester Encoded Packets
- 8-bit Cyclic Redundancy Check (CRC)
- Selectable data rates of 0.6, 1.0, 3.0 and 4.8kbps
- Internal clock generation requires no external components
- 0.3uA supply current in Standby Mode
- 130uA supply current during operation
- 1.8V to 3.6V Supply Voltage Range

Applications

- Remote Keyless Entry (RKE)
- Remote Car Starters
- Garage Door Openers (GDO)
- Remote Controls
- Remote Light Switches
- Remote Fan Controls
- Remote Thermostats
- Lawn Watering Sensors

RadioWire® and QwikRadio® RF Selection Guide

Micrel Advantange

- Highest Performance Transceivers
- Lowest Power
- High Sensitivity
- Micrel Net
- Low Component Count
- Easy to Design
- Modules Available

RF Remote Packet Generator

Device	Data Rate	Internal Address	Address Combos	CRC	Supply Current	Supply Voltage	Temp. Range	Package
MICRF302 <i>New!</i>	<4.8kbps	20-bit	>1M	8-bit	130µA	1.8V to 3.6V	-40°C to +85°C	MLF-10 (2.5mm x 2.5mm)

*See Product Highlight on previous page.

RF Transmitter (QwikRadio® and RadioWire®)

Device	Frequency Range	Modulation	Data Rate/ Modulation	Output Power	Supply Current	Supply Voltage	Temp. Range	Package
MICRF405 <i>New!</i>	290MHz–980MHz	ASK FSK	<200kbps FSK <50kbps ASK	+10dBm	18mA	2.2V to 3.6V	-40°C to +125°C	MLF-24 (4mm x 4mm)
MICRF113	300 to 450MHz	ASK OOK	<10kbps	+10dBm	12.3mA	1.8V to 3.6V	-40°C to +85°C	SOT-23-6 (2.8mm x 2.9mm)
MICRF112	300 to 450MHz	ASK FSK	<50kbps ASK <10kbps FSK	+10dBm	8.5mA 12.5mA	1.8V to 3.6V	-40°C to +125°C	MSOP-10 (3.0mm x 4.9mm)
MICRF103	800 to 1000MHz	ASK/OOK	115kbps	-3dBm	16mA	5V	-40°C to +85°C	SOIC-8 (4.9mm x 6.0mm)
MICRF102	300 to 470MHz	ASK/OOK	20kbps	-4dBm	4mA	5V	-40°C to +85°C	SOIC-8 (4.9mm x 6.0mm)

RF Receivers (QwikRadio®)

Device	Frequency Range	Modulation	Maximum Data Rate	Sensitivity	Supply Current	Supply Voltage	Temp. Range	Package
MICRF221 <i>New!</i>	850 to 950MHz	ASK/OOK	<10kbps	-109dBm @1kbps	9.0mA	3.0V to 3.6V	-40°C to +105°C	QSOP-16 (4.9mm x 6.0mm)
MICRF219 <i>New!</i>	300 to 450MHz	ASK/OOK	<10kbps	-110dBm @ 1kbps	4.0mA	3.0V to 3.6V	-40°C to +105°C	QSOP-16 (4.9mm x 6.0mm)
MICRF218	300 to 450MHz	ASK/OOK	<10kbps	-110dBm @ 1kbps	5.5mA	3.0V to 3.6V	-40°C to +85°C	QSOP-16 (4.9mm x 6.0mm)
MICRF213	300 to 350MHz	ASK/OOK	<7.2kbps	-110dBm @ 1kbps	3.9mA	3.0V to 3.6V	-40°C to +105°C	QSOP-16 (4.9mm x 6.0mm)
MICRF211	380 to 450MHz	ASK/OOK	<10kbps	-110dBm @ 1kbps	6.0mA	3.0V to 3.6V	-40°C to +105°C	QSOP-16 (4.9mm x 6.0mm)
MICRF010	300 to 440MHz	ASK/OOK	<2kbps	-105dBm @ 1kbps	2.9mA	5V	-40°C to +85°C	SOIC-8 (4.9mm x 6.0mm)
MICRF009	300 to 440MHz	ASK/OOK	<2kbps	-104dBm @ 1kbps	2.9mA	5V	-40°C to +85°C	SOIC-8 (4.9mm x 6.0mm)
MICRF007	300 to 440MHz	ASK/OOK	<3.2kbps	-99dBm @ 1kbps	2.3mA	5V	-40°C to +85°C	SOIC-8 (4.9mm x 6.0mm)

RF Transceivers (RadioWire®)

Device	Frequency Range	Modulation	Maximum Data Rate	Sensitivity	Output Power	Supply Current	Supply Voltage	Temp. Range	Package
MICRF505	850 to 950MHz	FSK	<200kbps	-111dBm @ 2.4kbps	+10dBm	13.5mA Rx 28mA Tx	2.0V to 2.5V	-40°C to +85°C	MLF-32 (5mm x 5mm)
MICRF506	410 to 450MHz	FSK	<200kbps	-113dBm @ 2.4kbps	+11dBm	12.0mA 21.5mA Tx	2.0V to 2.5V	-40°C to +85°C	MLF-32 (5mm x 5mm)

RF Transceiver Modules

Device	Frequency Range	Modulation	Maximum Data Rate	Sensitivity	Output Power	Supply Current	Supply Voltage	Temp. Range	Package
MICRF600	902 to 928MHz	FSK	<20kbps	-111dBm @ 2.4kbps	9dBm	13.2mA Rx 28mA Tx	2.0V to 2.5V	-20°C to +75°C	11.5 x 14.1
MICRF610	868 to 870MHz	FSK	<15kbps	-111dBm @ 2.4kbps	8.5dBm	13.6mA Rx 26mA Tx	2.0V to 2.5V	-20°C to +75°C	11.5 x 14.1
MICRF620	430 to 440MHz	FSK	<20kbps	-110dBm @ 2.4kbps	10dBm	12mA Rx 23mA Tx	2.0V to 2.5V	-20°C to +75°C	11.5 x 14.1

Electroluminescent Drivers Selection Guide

Micrel Advantange

- Low Noise
- Low Power
- Bright Light

Device	Description	Package
MIC4826	Low Input Voltage, 160V _{PP} Output Voltage EL Driver	MSOP-8
MIC4827	Low Input Voltage, 180V _{PP} Output Voltage EL Driver	MSOP-8
MIC4830	Low Input Voltage, Low Noise, 180V _{PP} Output Voltage EL Driver	MLF-10 (3mm x 3mm), MSOP-8
MIC4832	Low Input Voltage, Low Noise, 220V _{PP} Output Voltage EL Driver	MLF-10 (3mm x 3mm), MSOP-8
MIC4833	Low Input Voltage, Low Noise, 220V _{PP} Output Voltage EL Driver	MLF-12 (3mm x 3mm)
MIC4834	Low Input Voltage, Low Noise, 220V _{PP} Output Voltage EL Driver with Slew Rate Control	MLF-10 (3mm x 3mm), MSOP-10

Display Driver Selection Guide

Micrel Advantange

- High Current
- High Voltage
- Video Image Speeds

Device	Description	Segments	LEDs	Package
MIC5400	LED Video Display Driver		16	SOIC-28
MM5450	LED Display Driver	34		PDIP-40, PLCC-44
MM5451	LED Display Driver	35		PDIP-40, PLCC-44

Latched Driver Selection Guide

Device	Input	Number Output Channels	Nominal Sink Current	Nominal Source Current	Maximum Output Voltage	Thermal, UVLO, Overcurrent Protection	Packages			
							SOIC	PLCC	PDIP	CerDIP
MIC5800	Parallel	4	400mA	—	50V	—	14-pin	—	14-pin	—
MIC5801	Parallel	8	400mA	—	50V	—	24-pin	28-pin	22-pin	22-pin ⁽¹⁾
MIC58P01	Parallel	8	400mA	—	80V	Yes	24-pin wide	28-pin	22-pin	—
MIC5821	Serial	8	400mA	—	50V / 35V	—	—	—	16-pin	—
MIC5822	Serial	8	400mA	—	80V / 50V	—	—	—	16-pin	—
MIC5841	Serial	8	400mA	—	50V / 35V	—	18-pin wide	20-pin	18-pin	—
MIC5842	Serial	8	400mA	—	80V / 50V	—	18-pin wide	20-pin	18-pin	—
MIC58P42	Serial	8	400mA	—	80V / 50V	Yes	18-pin wide	20-pin	18-pin	—
MIC5891	Serial	8	—	400mA	50V	—	16-pin wide	—	16-pin	—
MIC59P50	Parallel	8	400mA	—	80V	Yes	24-pin wide	28-pin	24-pin	—
MIC59P60	Serial	8	400mA	—	80V / 50V	Yes	20-pin wide	20-pin	20-pin	—

1. SMD (military) 5962-8764001WA.

Ethernet Product Highlight — KSZ8692/9692

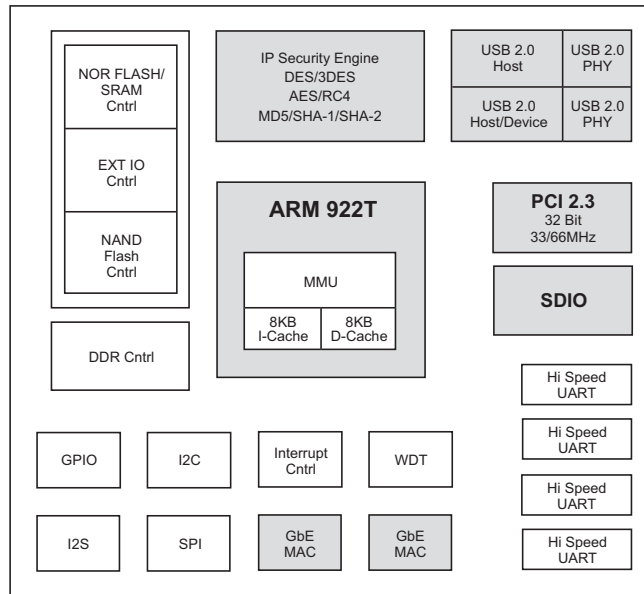

KSZ8692/9692

The KSZ9692PB is a highly integrated Gigabit Ethernet System-on-Chip (SoC) containing an ARM 922T 32-bit processor and a rich set of peripherals to address the cost-sensitive, high-performance needs of a wide variety of high bandwidth networking and communications applications.

Features

ARM 922T High-Performance Processor Core

- 250MHz ARM 922T RISC processor core
- 8KB I-cache and 8KB D-cache
- Configurable Memory Management Unit (MMU) for Linux and WinCE

Memory Controller

- 8/16-bit external bus interface for FLASH, ROM, SRAM, and external I/O
- NAND FLASH controller with boot option
- 200MHz 32-bit DDR controller
- Four JEDEC Specification JESD82-1 compliant differential clock drivers for a glueless DDR interface solution

Ethernet Interfaces

- Two GbE (10/100/1000 Mbps) MACs
- MII or RGMII interface
- Fully compliant with IEEE 802.3 Ethernet standards

IP Security Engine

- Hardware IPsec Engine guarantees 100Mbps VPN
- Secure Socket Layer Support
- DES/3DES/AES/RC4 Cyphers
- MD-5, SHA-1, SHA-256 Hashing Algorithms
- HMAC
- SSLMAC

PCI Interface

- Version PCI 2.3
- 32-bit 33/66MHz
- Integrated PCI Arbiter supports three external masters

- Configurable as Host bridge or Guest device
- Glueless Support for mini-PCI or CardBus devices

Dual High-Speed USB 2.0 Interfaces

- Two USB2.0 ports with integrated PHY
- Can be configured as 2-port host, or host + device

SDIO/SD Host Controller

- Meets SD Host Controller Standard Specification Version 1.0
- Meets SDIO card specification Version 1.0

DMA Controllers

- Dedicated DMA channels for PCI, USB, IPsec, SDIO and Ethernet ports

Peripherals

- Four high-speed UART ports up to 5Mbps
- Two programmable 32-bit timers with watchdog timer capability
- Interrupt Controller
- Twenty GPIO ports
- One shared SPI/I2C interface
- One I2S port

Debugging

- ARM9 JTAG debug interface
- JTAG Boundary Scan Support

Power Management

- CPU and system clock speed step-down options
- Ethernet port Wake-on-LAN
- DDR and PCI power down

Operating Voltage

- 1.2V power for core
- 3.3V power for I/O
- 2.5V power for DDR memory interface

Ethernet Selection Guide^(1,3)

Micrel Advantange

- Best-in-class patented mixed signal technology resulting in the lowest power dissipation in the industry for FE products
- Best-in-class feature sets for targeted applications (e.g. VoIP, ATA, IP-STB)
- Largest family of cost effective Embedded Controllers in the industry

Physical Layer Products

Part Number	Description	Package	Comments
KS8001L	Single 3.3V Supply, LinkMD [®] Cable Diagnostics, 10/100BASE-T/TX/FX MII and SMII, Digital Interface Physical Layer Transceiver with HP Auto-MDIX	LQFP-48	
KSZ8001L	Same as KS8001L (lead free version)	LQFP-48	
KSZ8001LI ⁽²⁾	Same as KSZ8001L (lead free version, Industrial version)	LQFP-48	
KS8001S	1.8V/3.3V Tolerant I/O, 10/100BASE-TX/FX MII Physical Layer Transceiver with Auto Crossover	SSOP-48	
KSZ8001S	Same as KS8001S (lead free version)	SSOP-48	
KSZ8001SI ⁽²⁾	Same as KSZ8001S (lead free, Industrial version)	SSOP-48	
KSZ8041NL	3.3V, 10BASE-T/100BASE-TX Physical Layer Transceiver	MLF-32	
KSZ8041NLI ⁽²⁾	Same as 3.3V, KSZ8041NL (lead free, Industrial version)	MLF-32	
KSZ8041TL	3.3V, 10BASE-T/100BASE-TX Physical Layer Transceiver (lead free version)	TQFP-48	
KSZ8041FTL	3.3V, 10BASE-T/100BASE-TX/FX Physical Layer Transceiver (lead free version)	TQFP-48	
KS8721B	2.5V/3.3V Tolerant I/O, 10/100BASE-TX/FX MII Physical Layer Transceiver with Auto Crossover	SSOP-48 and TQFP-48	
KSZ8721B	Same as KS8721 (lead free version)	SSOP-48 and TQFP-48	
KSZ8721BI ⁽²⁾	Same as KS8721 (lead free, Industrial version)	SSOP-48 and TQFP-48	
KS8721BL	3.3V 10/100BASE TX/FX MII Physical Layer Transceiver	LQFP-48	
KSZ8721BL	Same as KS8721BL (lead free version)	LQFP-48	
KS8721BLI ⁽²⁾	3.3V 10/100BASE TX/FX MII Physical Layer Transceiver (Industrial version)	LQFP-48	
KSZ8721BLI ⁽²⁾	Same as KS8721BLI (lead free, Industrial version)	LQFP-48	
KS8721BT	2.5V 10/100BASE-TX/FX MII Physical Layer Transceiver with Auto Crossover	TQFP-48	
KSZ8721BT	Same as KS8721BT (lead free version)	TQFP-48	
KS8721CL	Single 3.3V Supply, 10/100BASE-TX/FX MII Physical Layer Transceiver with Auto Crossover	LQFP-48	
KSZ8721CL	Same as KS8721CL (lead free version)	LQFP-48	
KS8721SL	3.3V 10/100BASE TX/FX MII Physical Layer Transceiver	SSOP-48	
KSZ8721SL	Same as KS8721SL (lead free version)	SSOP-48	
KSZ8721SLI ⁽²⁾	Same as KS8721SL (lead free, Industrial version)	SSOP-48	
KSZ9021GQ	<i>New!</i> Single Gigabit Ethernet Transceiver with GMII/MII	QFP-128	
KSZ9021GQ	<i>New!</i> Same as KSZ9021GQ (Industrial version)	QFP-128	
KSZ9021RL	<i>New!</i> Single Gigabit Ethernet Transceiver with RGMII	eLQFP-64	
KSZ9021RL	<i>New!</i> Same as KSZ9021RL (Industrial version)	eLQFP-64	

Layer 2 Switch Products - Unmanaged

Part Number	Description	Package	Comments
KS8993	3-Port 10/100 Integrated Switch	PQFP-128	
KS8993I ⁽²⁾	Industrial Temperature grade, 3-Port 10/100 Integrated Switch	PQFP-128	
KSZ8993	Same as KS8993 (lead free version)	PQFP-128	
KS8995XA	5-Port 10/100 Integrated Switch (Unmanaged)	PQFP-128	
KSZ8995XA	Same as KS8995XA (lead free version)	PQFP-128	
KS8995X	5-Port 10/100 Integrated Switch (Unmanaged)	PQFP-128	
KSZ8995X	Same as KS8995X (lead free version)	PQFP-128	
KS8997	8-Port 10/100 Integrated Switch	PQFP-128	
KSZ8997	Same as KS8997 (lead free version)	PQFP-128	
KS8999	9-Port 10/100 Integrated Switch	PQFP-208	
KSZ8999	Same as KS8999 (lead free version)	PQFP-208	
KS8999I ⁽²⁾	9-Port 10/100 Integrated Switch (Industrial version)	PQFP-208	
KSZ8999I ⁽²⁾	Same as KS8999I (lead free, Industrial version)	PQFP-208	

1. "KSZ" is the lead-free RoHS-compliant version of the KS part.
2. If the part number has an "I" at the end of it (e.g.: KSZ8721BI), this indicates it is industrial temperature tested.
3. With the exception of the KS8997, all of Micrel Ethernet Products may be used in Media Converter applications.

Embedded Controllers

Part Number	Description	Package	Comments
KSZ8841-16MQL	Single Port Ethernet MAC Controller with 8- or 16-Bit Generic Bus Interface (lead free version)	PQFP-128	
KSZ8841-16MVL	Single Port Ethernet MAC Controller with 8- or 16-Bit Generic Bus Interface (lead free version)	LQFP-128	
KSZ8841-16MVL ⁽²⁾	Single Port Ethernet MAC Controller with 8- or 16-Bit Generic Bus Interface (Industrial version)	LQFP-128	
KSZ8841-32MQL	Single Port Ethernet MAC Controller with 32b Generic Bus Interface (lead free version)	PQFP-128	
KSZ8841-32MVL	Single Port Ethernet MAC Controller with 32b Generic Bus Interface (lead free version)	LQFP-128	
KSZ8841-PMQL	Single Port Ethernet MAC Controller with 32b/33MHz PCI Interface (lead free version)	PQFP-128	
KSZ8841-PMQL ⁽²⁾	Single Port Ethernet MAC Controller with 32b/33MHz PCI Interface (Industrial version)	PQFP-128	
KSZ8842-16MQL	2-Port Ethernet Switch Plus 8-, 16-Bit Generic Bus Interface (lead free version)	PQFP-128	
KSZ8842-16MVL	2-Port Ethernet Switch Plus 8-, 16-Bit Generic Bus Interface (lead free version)	LQFP-128	
KSZ8842-16MVL ⁽²⁾	2-Port Ethernet Switch Plus 8-, 16-Bit Generic Bus Interface (Industrial version)	LQFP-128	
KSZ8842-32MQL	2-Port Ethernet Switch Plus 32-Bit Generic Bus Interface (lead free version)	PQFP-128	
KSZ8842-32MVL	2-Port Ethernet Switch Plus 32-Bit Generic Bus Interface (lead free version)	LQFP-128	
KSZ8842-PMQL	2-Port Ethernet Switch Plus 32b/33MHz PCI Interface (lead free version)	PQFP-128	
KSZ8842-PMQL ⁽²⁾	2-Port Ethernet Switch Plus 32b/33MHz PCI Interface (Industrial version)	PQFP-128	
KSZ8851-16MLL <i>New!</i>	Single-Port Ethernet MAC Controller with 8-Bit or 16-Bit Non-PCI Interface	LQFP-48	
KSZ8851-16MQL <i>New!</i>	Single-Port Ethernet MAC Controller with 8/16-Bit or 32-Bit Non-PCI Interface	PQFP-128	
KSZ8851SNL <i>New!</i>	Single-Port Ethernet Controller with SPI Interface	MLF-32	

Layer 2 Switch Products - Managed

Part Number	Description	Package	Comments
KSZ8842-16MQL	2-Port Ethernet Switch Plus 8-, 16-Bit Generic Bus Interface (lead free version)	PQFP-128	
KSZ8842-16MVL	2-Port Ethernet Switch Plus 8-, 16-Bit Generic Bus Interface (lead free version)	LQFP-128	
KSZ8842-16MVL ⁽²⁾	2-Port Ethernet Switch Plus 8-, 16-Bit Generic Bus Interface (Industrial version)	LQFP-128	
KSZ8842-32MQL	2-Port Ethernet Switch Plus 32-Bit Generic Bus Interface (lead free version)	PQFP-128	
KSZ8842-32MVL	2-Port Ethernet Switch Plus 32-Bit Generic Bus Interface (lead free version)	LQFP-128	
KSZ8842-PMQL	2-Port Ethernet Switch Plus 32b/33MHz PCI Interface (lead free version)	PQFP-128	
KSZ8842-PMQL ⁽²⁾	2-Port Ethernet Switch Plus 32b/33MHz PCI Interface (Industrial version)	PQFP-128	
KSZ8893MQL	3-Port Ethernet Switch (lead free version)	PQFP-128	
KSZ8893MQL ⁽²⁾	3-Port Ethernet Switch (Industrial version)	PQFP-128	
KS8993M	3-Port 10/100 Integrated Switch	PQFP-128	
KSZ8993M	Same as KS8993M (lead free version)	PQFP-128	
KS8993MI ⁽²⁾	3-Port 10/100 Integrated Switch (Industrial version)	PQFP-128	
KSZ8993MI ⁽²⁾	Same as KS8993MI (lead free version)	PQFP-128	
KS8993ML	Single 3.3V, 3-Port 10/100 Integrated Switch	PQFP-128	
KSZ8993ML	Same as KS8993ML (lead free version)	PQFP-128	
KS8995M	5-Port 10/100 Integrated Managed Switch	PQFP-128	
KSZ8995M	Same as KS8995M (lead free version)	PQFP-128	
KS8995MI ⁽²⁾	5-Port 10/100 Integrated Managed Switch, (Industrial version)	PQFP-128	
KSZ8995MI ⁽²⁾	Same as KS8995MI (lead free, Industrial version)	PQFP-128	
KS8995MA	5-Port 10/100 Integrated Managed Switch	PQFP-128	
KSZ8995MA	Same as KS8995MA (lead free version, FX on port 4, 5)	PQFP-128	
KS8995MAI ⁽²⁾	5-Port 10/100 Integrated Managed Switch (Industrial version)	PQFP-128	
KSZ8995MAI ⁽²⁾	Same as KS8995MAI (lead free, Industrial version)	PQFP-128	
KSZ8995FQ	Same as KS8995MA (lead free version, FX on port 3, 4)	PQFP-128	

1. "KSZ" is the lead-free RoHS-compliant version of the KS part.

2. If the part number has an "I" at the end of it (e.g.: KSZ8721BI), this indicates it is industrial temperature tested.

3. With the exception of the KS8997, all of Micrel Ethernet Products may be used in Media Converter applications.

System-On-a-Chip

Part Number	Description	Package	Comments
KSZ8692PB	<i>New!</i> Integrated 10/100Mbps Ethernet and Communication Controller with IPSec	PBGA-400	
KSZ8692PBI	<i>New!</i> Same as KSZ8692PB (Industrial version)	PBGA-400	
KSZ8692XPB	<i>New!</i> Integrated 10/100Mbps Ethernet and USB Controller	PBGA-400	
KS8695X	5-Port 10/100 Managed Switch and PHY	PQFP-208	
KSZ8695X	Same as KS8695X (lead free version)	PQFP-208	
KS8695P	5-Port 10/100 Integrated Managed Switch and PHY with 3 PCI Master Support	PBGA-289	
KSZ8695P	Same as KS8695P (lead free version)	PBGA-289	
KS8695PI ⁽²⁾	Industrial version of KS8695P	PBGA-289	
KSZ8695PI ⁽²⁾	Industrial version of KSZ8695P	PBGA-289	
KS8695PX	5-Port 10/100 Integrated Managed Switch and PHY with 1 PCI Master Support	PBGA-289	
KSZ8695PX	Same as KS8695PX (lead free version)	PBGA-289	
KSZ9692PB	<i>New!</i> Integrated Gigabit Ethernet and Communication Controller with IPSec	PBGA-400	
KSZ9692PBI	<i>New!</i> Same as KSZ9692PB (Industrial version)	PBGA-400	
KSZ9692XPB	<i>New!</i> Integrated Gigabit Ethernet and USB Controller	PBGA-400	

Media Converters

Part Number	Description	Package	Comments
KSZ8862-16MQL	2-Port Ethernet Switch with Integrated 10B-FL/100B-SX LED Driver and Post Amplifier Plus 8- or 16-bit Generic Bus Interface	PQFP-128	
KSZ8862-16MQL-FX	2-Port Ethernet Switch with 100B-FX TTC TS-1000 V2-Compliant OAM Sublayer Plus 8- or 16-bit Generic Bus Interface	PQFP-128	
KSZ8862-32MQL	2-Port Ethernet Switch with Integrated 10B-FL/100B-SX LED Driver and Post Amplifier plus 32-bit Generic Bus interface	PQFP-128	
KSZ8862-32MQL-FX	2-Port Ethernet Switch with 100B-FX TTC TS-1000 V2-Compliant OAM Sublayer Plus 32-bit Generic Bus Interface	PQFP-128	
KSZ8893FQL	3-Port Ethernet Switch with Integrated 10B-FL/100B-SX LED Driver and Post Amplifier	PQFP-128	
KSZ8893FQL-FX	3-Port Ethernet Switch with 100B-FX TTC TS-1000 V2-Compliant OAM Sublayer	PQFP-128	
KS8993F	Single Chip Fast Ethernet Media Converter with TTC TS-1000-Compliant OAM Sublayer	PQFP-128	
KSZ8993F	Same as KS8993F (lead free version)	PQFP-128	
KS8993FL	Single Chip Fast Ethernet Media Converter with TTC TS-1000-Compliant OAM Sublayer	PQFP-128	
KSZ8993FL	Same as KS8993FL (lead free version)	PQFP-128	

1. "KSZ" is the lead-free RoHS-compliant version of the KS part.
2. If the part number has an "I" at the end of it (e.g.: KSZ8721BI), this indicates it is industrial temperature tested.
3. With the exception of the KS8997, all of Micrel Ethernet Products may be used in Media Converter applications.

Precision Edge[®] Product Family Highlight – SY56xxx

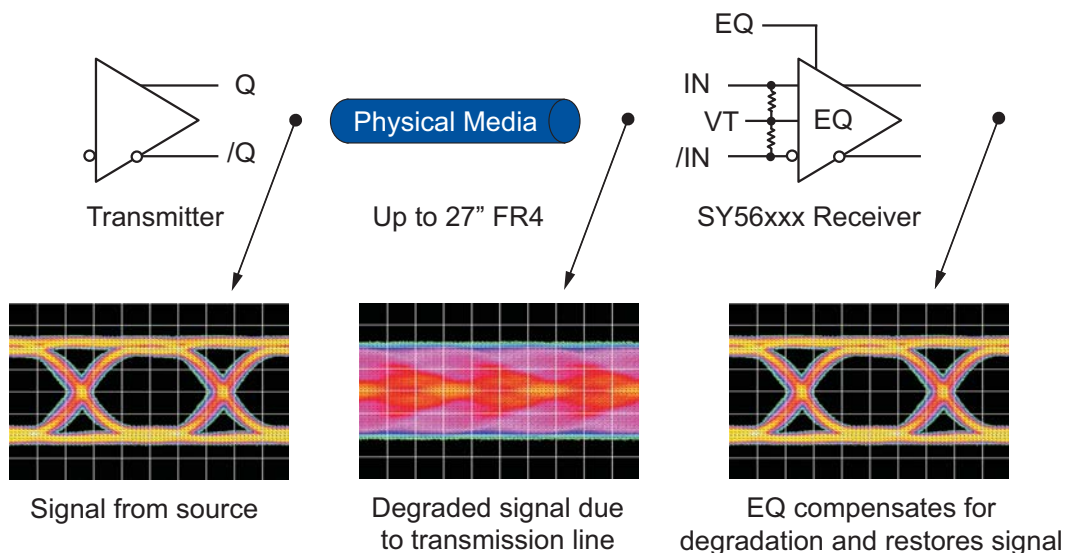

SY56xxx, 6.4Gbps Low Voltage CML Family with Equalization

The products in the SY56xxx family are fully differential and operate up to 5GHz or 6.4Gbps. The input structures of these products have an Equalization (EQ) circuit that compensates for signal degradation caused by the transmission medium. The EQ circuit can compensate for up to 27" of FR4 signal attenuation.

The differential input includes Micrel's unique, 3-pin input termination architecture that interfaces to ANY differential signal, without any level-shifting or termination resistor networks in the signal path. The differential input can accept AC-coupled CML, LVPECL, and LVDS signals.

The SY56xxx family operates from a 2.5V $\pm 5\%$ core supply and a 1.2V, 1.8V or 2.5V $\pm 5\%$ output supply and is guaranteed to operate over the full industrial temperature range, from -40°C to $+85^{\circ}\text{C}$.

Features

- 1.2V/1.8V/2.5V CML Differential Line Driver/Receiver with Equalization
- Equalizes 9, 18, 27 inches of FR4
- Guaranteed AC performance over temperature and voltage:
 - DC-to >6.4Gbps Data throughput
 - DC-to >5.0GHz Clock throughput
 - <250ps propagation delay (IN-to-Q)
 - <80ps rise/fall times
- Ultra-low jitter design

– <1psRMS random jitter

- High-speed CML outputs
- 2.5V $\pm 5\%$ V_{CC} , 1.2V/1.8V/2.5V $\pm 5\%$ V_{CCO} power supply operation
- Industrial temperature range: -40°C to $+85^{\circ}\text{C}$
- Available in MLF[®] packages

Applications

- Data Distribution
- SONET/SDH
- Fibre Channel
- Gigabit Ethernet
- SMPTE

Markets

- Telecom/Datacom
- Storage
- Test and measurement
- Video
- High-end servers

Part Number	Function	Package
SY56011R	1:2 Fanout Buffer with Equalization	16-Pin 3mm x 3mm MLF [®]
SY56017R	2:1 Multiplexer with Equalization	16-Pin 3mm x 3mm MLF [®]
SY56023R	2x2 Crosspoint Switch with Equalization	16-Pin 3mm x 3mm MLF [®]
SY56020R <i>New!</i>	1:4 Fanout Buffer with Equalization	16-Pin 3mm x 3mm MLF [®]
SY56216R <i>New!</i>	Dual Channel Buffer with Equalization	16-Pin 3mm x 3mm MLF [®]
SY56034AR <i>New!</i>	2x2 Crosspoint Switch with Six Outputs	32-Pin 5mm x 5mm MLF [®]
SY56040AR <i>New!</i>	4x4 Crosspoint Switch without Equalization	44-Pin 7mm x 7mm MLF [®]
SY56016R <i>New!</i>	Low Voltage CML Buffer with Equalization	10-Pin 2mm x 2mm MLF [®]

Precision Edge[®] Selection Guide

Micrel Advantage

- Highest precision, lowest Jitter
 - Internal Termination — Stubless Design
 - MUX Isolation — 70% Crosstalk Noise Improvement
 - Fail-Safe Input — Prevents Metastable Condition
 - Runt Pulse Elimination
- Highest Speed
 - CML
 - LVPECL
 - LVDS
- Smallest Footprint
 - MLF[®] Package
 - Integration

Clock Distribution

Part Number	Fanout	Input	Output	Voltage	Max. Freq. (GHz)	Package	Description
SY54011R	1:2	ANY	CML	1.2/1.8V	3.2	MLF-16	Low Voltage CML Fanout Buffer/Translator.
SY56011R	1:2	ANY	CML	1.2/1.8/2.5V	4.5	MLF-16	Low Voltage EQ Fanout Buffer.
SY56020R <i>New!</i>	1:4	ANY	CML	1.2/1.8/2.5V	4.5	MLF-16	Low Voltage EQ Fanout Buffer.
SY58011U	1:2	ANY	CML	2.5/3.3V	7	MLF-16	Fanout Buffer/Translator.
SY58012U	1:2	ANY	LVPECL	2.5/3.3V	5	MLF-16	Fanout Buffer/Translator.
SY58013U	1:2	ANY	RS-LVPECL	2.5/3.3V	6	MLF-16	Fanout Buffer/Translator with 400mV Output Swing.
SY58020U	1:4	ANY	CML	2.5/3.3V	6	MLF-16	Fanout Buffer/Translator.
SY58021U	1:4	ANY	LVPECL	2.5/3.3V	4	MLF-16	Fanout Buffer/Translator.
SY58022U	1:4	ANY	RS-LVPECL	2.5/3.3V	5.5	MLF-16	Fanout Buffer/Translator with 400mV Output Swing.
SY58031U	1:8	ANY	CML	2.5/3.3V	5	MLF-32	Fanout Buffer.
SY58032U	1:8	ANY	LVPECL	2.5/3.3V	4	MLF-32	Fanout Buffer.
SY58033U	1:8	ANY	RS-LVPECL	2.5/3.3V	5.5	MLF-32	Fanout Buffer with 400mV Output Swing.
SY58034U	2:6	ANY	CML	2.5/3.3V	6	MLF-32	Fanout Buffer w/2:1 MUX Input.
SY58035U	2:6	ANY	LVPECL	2.5/3.3V	4.5	MLF-32	Fanout Buffer w/2:1 MUX Input.
SY58036U	2:6	ANY	RS-LVPECL	2.5/3.3V	6	MLF-32	Fanout Buffer w/2:1 MUX Input and 400mV Output Swing.
SY58606U	1:2	ANY	CML	2.5/3.3V	2.5	MLF-16	Fanout Buffer with Fail-Safe Input.
SY58607U	1:2	ANY	LVPECL	2.5/3.3V	2.5	MLF-16	Fanout Buffer with Fail-Safe Input.
SY58608U	1:2	ANY	LVDS	2.5V	2	MLF-16	Fanout Buffer with Fail-Safe Input.
SY89112U	2:12	ANY	LVPECL	2.5/3.3V	3	MLF-44	Improved EP111 Replacement.
SY89113U	2:12	ANY	LVDS	2.5V	1	MLF-44	Fanout Buffer.
SY89200U	1:8	ANY	LVDS	2.5V	1.5	MLF-32	3 Banks (+1, +2, +4).
SY89202U	1:8	ANY	LVPECL	2.5/3.3V	1.5	MLF-32	3 Banks (+1, +2, +4).
SY89311U	1:2	ECL/PECL/LVPECL/LVECL	ECL/PECL/LVPECL/LVECL	2.5/3.3/5V	3	MLF-8	Differential Fanout Buffer.
SY89467U	2:20	ANY	LVPECL	2.5/3.3V	1.5	TQFP-64	Fanout Buffer with Fail-Safe Input.
SY89468U	2:20	ANY	LVDS	2.5V	1.5	TQFP-64	Fanout Buffer with Fail-Safe Input.
SY89645L	1:4	LVCOS/LVTTL	LVDS	3.3V	0.65	TSSOP-16	LVCOS/LVTTL-to-LVDS Fanout Buffer.
SY89808L	1:9	LVPECL/HSTL	HSTL	3.3V	0.5	TQFP-32	Fanout Buffer.
SY89809L	1:9	LVPECL/HSTL	HSTL	3.3V	0.5	TQFP-32	Bus Clock Driver.
SY89823L	1:22	LVPECL/HSTL	HSTL	3.3V	0.5	TQFP-64	Fanout Buffer/Translator.
SY89824L	1:22	LVPECL/HSTL	HSTL	3.3V	0.5	TQFP-64	Bus Clock Driver.
SY89825U	1:22	LVPECL/LVDS	LVPECL	2.5/3.3V	1	TQFP-64	Bus Clock Driver/Translator.
SY89826L	1:22	LVPECL/LVDS	LVDS	3.3V	1	TQFP-64	Fanout Buffer/Translator.
SY89827L	Dual 1:10	LVPECL/HSTL	HSTL	3.3V	0.5	TQFP-64	Fanout Buffer/Translator.
SY89828L	Dual 1:10	LVPECL/LVDS	LVDS	3.3V	1	TQFP-64	Fanout Buffer/Translator.
SY89829U	Dual 1:10	LVPECL/LVDS	LVPECL	2.5/3.3V	2	TQFP-64	Clock Driver.
SY89830U	2:4	ECL/PECL/LVPECL/LVECL	ECL/PECL/LVPECL/LVECL	2.5/3.3/5V	2.5	TSSOP-16	Clock Driver with 2:1 MUX Input.
SY89831U	1:4	ANY	LVPECL	2.5/3.3V	2.0	MLF-16	Fanout Buffer/Translator.
SY89832U	1:4	ANY	LVDS	2.5V	2.0	MLF-16	Fanout Buffer/Translator.
SY89833L	1:4	ANY	LVDS	3.3V	2	MLF-16	Fanout Buffer/Translator.
SY89834U	2:4	LVTTL	LVPECL	2.5/3.3V	1	MLF-16	Fanout Buffer with 2:1 MUX Input.
SY89837U	2:8 RPE	ANY	LVPECL	2.5/3.3V	1.5	MLF-32	RPE, FSI Fanout with 2:1 MUX Input.

Clock Distribution (continued)

Part Number	Fanout	Input	Output	Voltage	Max. Freq. (GHz)	Package	Description
SY89838U	2:8 RPE	ANY	LVDS	2.5V	1.5	MLF-32	RPE, FSI Fanout with 2:1 MUX Input.
SY89843U	2:2 RPE	ANY	LVPECL	2.5/3.3V	1.5	MLF-24	RPE, FSI Fanout with 2:1 MUX Input.
SY89844U	2:2 RPE	ANY	LVDS	2.5V	1.5	MLF-24	RPE, FSI Fanout with 2:1 MUX Input.
SY89464U	2:10 RPE	ANY	LVPECL	2.5/3.3V	2	MLF-44	RPE, FSI Input MUX with 2:1 MUX Input.
SY89465U	2:10 RPE	ANY	LVDS	2.5V	2	MLF-44	RPE, FSI Input MUX with 2:1 MUX Input.
SY89473U	2:2	ANY	LVPECL	2.5/3.3V	3	MLF-24	Fanout Buffer/Translator.
SY89474U	2:2	ANY	LVDS	2.5V	2.5	MLF-24	Fanout Buffer/Translator.
SY89846U	2:5	ANY	LVPECL	2.5/3.3V	1.5	MLF-32	Fanout Buffer with Fail-Safe Input.
SY89847U	2:5	ANY	LVDS	2.5V	1.5	MLF-32	Fanout Buffer with Fail-Safe Input.
SY89850U	1:1	ANY	LVPECL	2.5/3.3V	4	MLF-8	LVPECL Line Driver/Receiver.
SY89851U	1:2	ANY	LVPECL	2.5/3.3V	3	MLF-16	Low Power Fanout Buffer/Trans.
SY89854U	1:4	ANY	LVPECL	2.5/3.3V	3.5	MLF-16	Low Power Fanout Buffer/Trans.
SY89856U	2:6	ANY	LVPECL	2.5/3.3V	3	MLF-32	Low Power Fanout Buffer with 2:1 MUX Input.
SY89858U	1:8	ANY	LVPECL	2.5/3.3V	3	MLF-32	Low Power Fanout Buffer.

Clock Dividers/Generators

Part Number	Fanout Buffer	Input	Output	Voltage	Max. Freq. (GHz)	Package	Description
SY89200U	Y	ANY	LVDS	2.5V	1.5	MLF-32	3 Banks (+1, +2, +4) 8 Total.
SY89202U	Y	ANY	LVPECL	2.5/3.3V	1.5	MLF-32	3 Banks (+1, +2, +4) 8 Total.
SY89218U	Y	ANY	LVDS	2.5V	1.5	TQFP-64	4 Banks (+1, +2, +4) 15 Total FSI Input.
SY89221U	Y	ANY	LVPECL	2.5/3.3V	1.5	TQFP-64	4 Banks (+1, +2, +4) 15 Total FSI Input.
SY89228U	N	ANY	LVPECL	2.5/3.3V	1	MLF-16	+3, +5 FSI Input.
SY89229U	N	ANY	LVDS	2.5V	1	MLF-16	+3, +5 FSI Input.
SY89230U	N	ANY	LVPECL	2.5/3.3V	3.2	MLF-16	+3, +5.
SY89231U	N	ANY	LVDS	2.5V	3.2	MLF-16	+3, +5.
SY89312V	N	ECL/PECL	ECL/PECL	3.3/5V	4	MLF-8	+2.
SY89313V	N	ECL/PECL	ECL/PECL	3.3/5V	4	MLF-8	+4.
SY89871U	Y	ANY	LVPECL	2.5/3.3V	2.5	MLF-16	2 Banks (+1, +2, +4, +8, +16).
SY89872U	Y	ANY	LVDS	2.5V	2	MLF-16	2 Banks (+1, +2, +4, +8, +16).
SY89873L	Y	ANY	LVDS	3.3V	2	MLF-16	2 Banks (+1, +2, +4, +8, +16).
SY89874U	Y	ANY	LVPECL	2.5/3.3V	2.5	MLF-16	+1, +2, +4, +8, +16.
SY89875U	Y	ANY	LVDS	2.5V	2	MLF-16	+1, +2, +4, +8, +16.
SY89876L	Y	ANY	LVDS	3.3V	2	MLF-16	+1, +2, +4, +8, +16.
SY100S834L	N	ECL/PECL/LVPECL	ECL/PECL	3.3/5V	—	SOIC-16	(+1, 2, 4) or (+2, 4, 8).
SY100S838L	N	ECL/PECL/LVPECL	ECL/PECL	3.3/5V	—	SOIC-20	(+1, 2/3) or (+2, 4/6).
SY100S839V	N	ECL/PECL/LVPECL	ECL/PECL	3.3/5V	—	SOIC-20	(+2/4) or (+4/5/6).

Crosspoint Switches

Part Number	Input	Output	Voltage	Max. Data Rate (Gbps)	Package	Description
SY54023R	ANY	CML	1.2/1.8V	3.2	MLF-16	2x2 with Fail-Safe Inputs.
SY56023R	ANY	CML	1.2/1.8/2.5V	6.4	MLF-16	2x2 with Equalization.
SY56034AR <i>New!</i>	ANY	CML	1.2/1.8/2.5V	6.4	MLF-32	2x2 Crosspoint Switch with Six Outputs.
SY56040AR <i>New!</i>	ANY	CML	1.2/1.8/2.5V	6.4	MLF-44	4x4 Crosspoint Switch.
SY58023U	ANY	CML	2.5/3.3V	10.7	MLF-16	2x2.
SY58024U	ANY	CML	2.5/3.3V	10.7	MLF-32	Dual 2x2.
SY58040U	ANY	CML	2.5/3.3V	5	MLF-44	4x4.
SY89540U	ANY	LVDS	2.5V	3.2	MLF-44	4x4.
SY55854U	ANY	CML	2.5/3.3/5V	2.5	QSOP-16	2x2.
SY55858U	CML/PECL/LVPECL	CML	2.5/3.3V	3	TQFP-32	Dual 2x2.
SY55859L	CML	CML	3.3V	2.7	MLF-32	Dual 2x2.

Clock Synthesis

Part Number	Input	Output	Voltage	Min Freq. (MHz)	Max Freq. (MHz)	Package	Description
SY87729L	XTAL	PECL	3.3V	10	365	TQFP-32	AnyClock® Fractional-N Synthesizer.
SY87739L	XTAL	PECL	3.3V	10	730	TQFP-32	AnyClock® Fractional-N Synthesizer.
SY89426	TTL	PECL	5V	33	622	PLCC-28	SONET OC-12/OC-3.
SY89529L	XTAL	LVPECL	3.3V	—	200	TQFP-32, SOIC-28	Spectrum Clock Synthesizer.
SY89531L	XTAL	HSTL/LVPECL	3.3V	33	500	TQFP-64	XTAL Input Synthesizer.
SY89532L	XTAL	LVPECL	3.3V	33	500	TQFP-64	XTAL Input Synthesizer.
SY89533L	XTAL	LVDS/LVPECL	3.3V	33	500	TQFP-64	XTAL Input Synthesizer.
SY89534L	ANYX	LVPECL	3.3V	33	500	TQFP-64	Reference Input Synthesizer.
SY89535L	ANYX	LVDS/LVPECL	3.3V	33	500	TQFP-64	Reference Input Synthesizer.
SY89536L	ANYX	HSTL/LVPECL	3.3V	33	500	TQFP-64	Reference Input Synthesizer.
SY89537L	ANYX	LVDS/LVPECL	3.3V	73	750	MLF-44	Reference and XTAL Prog. Frequency.
SY89538L	ANYX	LVDS/LVPECL	3.3V	73	750	TQFP-64	Reference Input, Multiple Banks, Zero Delay.
SY89610L	ANY	CML	3.3V	19	694	MLF-32	Clock Synthesizer with Ultra Low Jitter.

Receivers/Buffers/Drivers

Part Number	Input	Output	Voltage	Max. Data Rate (Gbps)	Max. Freq. (GHz)	Package	Description
SY54016R	ANY	CML	1.2/1.8V	3.2	2.5	MLF-8 (2mm x 2mm)	Low Voltage CML Translator with Fail-Safe Input.
SY54016AR	ANY	CML	1.2/1.8V	3.2	3.2	MLF-8 (2mm x 2mm)	Low Voltage CML Translator.
SY56016R <i>New!</i>	ANY	CML	1.2/1.8/2.5V	6.4	5	MLF-10 (2mm x 2mm)	Differential Line Driver with EQ.
SY56216R <i>New!</i>	ANY	CML	1.2/1.8/2.5V	6.4	5	MLF-16 (3mm x 3mm)	Dual Channel EQ Buffer.
SY58016L	CML/PECL	CML	3.3V	10.7	7	MLF-16 (3mm x 3mm)	Differential CML Line Driver/Receiver.
SY58600U	ANY	CML	2.5/3.3V	10.7	7	MLF-8 (2mm x 2mm)	Line/Driver Receiver.
SY58601U	ANY	LVPECL	2.5/3.3V	5	5	MLF-8 (2mm x 2mm)	Line/Driver Receiver.
SY58602U	ANY	RS-LVPECL	2.5/3.3V	10.7	7	MLF-8 (2mm x 2mm)	Line/Driver Receiver with 400mV Output Swing.
SY58603U	ANY	CML	2.5/3.3V	4.25	2.5	MLF-8 (2mm x 2mm)	Line/Driver Receiver with Fail-Safe Input.
SY58604U	ANY	LVPECL	2.5/3.3V	3.2	2.5	MLF-8 (2mm x 2mm)	Line/Driver Receiver with Fail-Safe Input.
SY58605U	ANY	LVDS	2.5V	3.2	2	MLF-8 (2mm x 2mm)	Line/Driver Receiver with Fail-Safe Input.
SY58620L	ANY	CML	3.3V	4.25	2.5	MLF-24 (4mm x 4mm)	Backplane Transceiver.
SY89206V	ECL/PECL	ECL/PECL	3.3/5V	—	1	MLF-8 (2mm x 2mm)	Receiver/Buffer-100k Comp.
SY89207L	LVECL/LVPECL	PECL	3.3V	—	0.8	MSOP-10	Amp. w/Low-Gain Feedback.
SY89216V	ECL/PECL	ECL/PECL	3.3/5V	—	1	MLF-8 (2mm x 2mm)	Receiver/Buffer-10k Comp.
SY89250V	ECL/PECL	ECL/PECL	3.3/5V	—	—	MLF-8 (2mm x 2mm)	Enhanced Differential Receiver.
SY89306V	ECL/PECL	ECL/PECL	3.3/5V	—	2.5	MLF-8 (2mm x 2mm)	Receiver/Buffer-100k Comp.
SY89307V	ECL/PECL	ECL/PECL	3.3/5V	2.5	—	MLF-8 (2mm x 2mm)	Variable Output Swing Differential Receiver.
SY89316V	ECL/PECL	ECL/PECL	3.3/5V	—	2.5	MLF-8 (2mm x 2mm)	Differential Receiver/Buffer-10k Comp.
SY89835U	LVDS	LVDS	2.5V	3.2	2	MLF-8 (2mm x 2mm)	Buffer with Fail-Safe Input.
SY89850U	CML/PECL/LVDS	LVPECL	2.5/3.3V	3.2	4	MLF-8 (2mm x 2mm)	Low Power.

Gates and Flip-Flops

Part Number	Input	Output	Voltage	Max. Freq. (GHz)	Package	Description
SY58051U	ANY	CML	2.5/3.3V	7	ANY-16	CML AnyGate®.
SY58052U	ANY	CML	2.5/3.3V	10.7	MLF-16	Data/Clock Synchronizer.
SY55851/A	CML/PECL/LVPECL	CML	2.5/3.3V	3	MSOP-10	CML AnyGate®.
SY55852U	CML/PECL/LVPECL	CML	2.5/3.3/5V	2.5	MSOP-10	D Flip Flop.
SY55853U	CML/PECL/LVPECL	CML	2.5/3.3/5V	2.5	MSOP-10	D Latch.

Multiplexers

Part Number	Fanout	Input	Output	Voltage	Frequency (Gbps)	Max. Freq. (GHz)	Package	Description
SY54017R	2:1	ANY	CML	1.2/1.8V	3.2	2.5	MLF-16	Low Voltage CML with Fail-Safe Input.
SY54017AR	2:1	ANY	CML	1.2/1.8V	3.2	2.5	MLF-16	Low Voltage CML MUX.
SY56017R	2:1	ANY	CML	1.2/1.8/2.5V	6.4	3.2	MLF-16	Low Voltage EQ MUX.
SY58017U	2:1	ANY	CML	2.5/3.3V	10.7	7	MLF-16	Internal Termination.
SY58018U	2:1	ANY	LVPECL	2.5/3.3V	5	4	MLF-16	Internal Termination and 800mV Output Swing.
SY58019U	2:1	ANY	RS-LVPECL	2.5/3.3V	10.7	7	MLF-16	Internal Termination and 400mV Output Swing.
SY58025U	Dual 2:1	ANY	CML	2.5/3.3V	10.7	7	MLF-32	Internal Termination.
SY58026U	Dual 2:1	ANY	LVPECL	2.5/3.3V	5	6	MLF-32	Internal Termination and 800mV Output Swing.
SY58027U	Dual 2:1	ANY	RS-LVPECL	2.5/3.3V	10.7	6	MLF-32	Internal Termination and 400mV Output Swing.
SY58028U	4:2	ANY	CML	2.5/3.3V	10.7	7	MLF-32	Internal Termination.
SY58029U	4:2	ANY	LVPECL	2.5/3.3V	5	4	MLF-32	Internal Termination and 800mV Output Swing.
SY58030U	4:2	ANY	RS-LVPECL	2.5/3.3V	10.7	7	MLF-32	Internal Termination and 400mV Output Swing.
SY58037U	8:2	ANY	CML	2.5/3.3V	5	4	MLF-44	Internal Termination.
SY58038U	8:2	ANY	LVPECL	2.5/3.3V	4.5	5	MLF-44	Internal Termination and 800mV Output Swing.
SY58039U	8:2	ANY	RS-LVPECL	2.5/3.3V	5	5.5	MLF-44	Internal Termination and 400mV Output Swing.
SY58609U	2:1	ANY	CML	2.5/3.3V	4.25	2.5	MLF-16	Fail-Safe Input and Internal Termination.
SY58610U	2:1	ANY	LVPECL	2.5/3.3V	3.2	2.5	MLF-16	Fail-Safe Input and Internal Termination.
SY58611U	2:1	ANY	LVDS	2.5V	3.2	2.5	MLF-16	Fail-Safe Input and Internal Termination.
SY89208V	2:1	ECL/PECL	ECL/PECL	3.3/5V	—	3	MLF-8	Internal Termination and 800mV Output Swing.
SY89464U	2:10	ANY	LVPECL	2.5/3.3V	—	2	MLF-44	Internal Termination and 800mV Output Swing.
SY89465U	2:10	ANY	LVDS	2.5V	—	2	MLF-44	Fast Edge Rates and Internal Termination.
SY89473U	2:2	ANY	LVPECL	2.5/3.3V	3.2	3	MLF-24	Internal Termination and 800mV Output Swing.
SY89474U	2:2	ANY	LVDS	2.5V	3.2	4	MLF-24	Fast Edge Rates and Internal Termination.
SY89542U	Dual 2:1	ANY	LVDS	2.5V	3.2	4	MLF-32	Fast Edge Rates and Internal Termination.
SY89543L	Dual 2:1	ANY	LVDS	3.3V	3.2	3	MLF-32	Fast Edge Rates and Internal Termination.
SY89544U	4:1	ANY	LVDS	2.5V	3.2	4	MLF-32	Fast Edge Rates and Internal Termination.
SY89545L	4:1	ANY	LVDS	3.3V	3.2	3	MLF-32	Fast Edge Rates and Internal Termination.
SY89546U	4:2	ANY	LVDS	2.5V	3.2	4	MLF-32	Fast Edge Rates and Internal Termination.
SY89547L	4:2	ANY	LVDS	3.3V	3.2	4	MLF-32	Fast Edge Rates and Internal Termination.
SY89840U	2:1	ANY	LVPECL	2.5/3.3V	—	2	MLF-16	Internal Termination and 800mV Output Swing.
SY89841U	2:1	ANY	LVDS	2.5V	—	1.5	MLF-16	Fast Edge Rates and Internal Termination.
SY89842U	2:1	ANY	CML	2.5/3.3V	—	2	MLF-16	Internal Termination.
SY89843U	2:2	ANY	LVPECL	2.5/3.3V	—	2	MLF-24	Internal Termination and 800mV Output Swing.
SY89844U	2:2	ANY	LVDS	2.5V	—	2	MLF-24	Fast Edge Rates and Internal Termination.
SY89845U	2:2	ANY	CML	2.5/3.3V	—	2	MLF-24	Internal Termination.
SY89852U	2:1	ANY	LVPECL	2.5/3.3V	3.2	3.5	MLF-16	Internal Termination and 800mV Output Swing.
SY89853U	Dual 2:1	ANY	LVPECL	2.5/3.3V	2.5	2.5	MLF-32	Internal Termination and 800mV Output Swing.
SY89855U	4:2	ANY	LVPECL	2.5/3.3V	2.5	2.5	MLF-32	Internal Termination and 800mV Output Swing.
SY89859U	8:2	ANY	LVPECL	2.5/3.3V	2.5	3.5	MLF-44	Internal Termination and 800mV Output Swing.

Backplane and Cable Management Solutions

Part Number	Input	Output	Voltage	Max. Data Rate (Gbps)	Package	Description
SY58620L	ANY	CML	3.3V	4.25	MLF-24	Backplane Transceiver with Integrated Loopback.
SY58621L	ANY	LVPECL/CML	3.3V	3.2	MLF-24	Backplane Transceiver with Integrated Loopback.
SY58626L	ANY	CML	3.3V	6.4	MLF-32	Pre-Emphasis Driver with Integrated Loopback.
SY58627L	ANY	CML	3.3V	6.4	MLF-32	Equalization Receiver with Integrated Loopback.

Phase-Locked Loop

Part Number	Input	Output	Voltage	Max. Data Rate (Gbps)	Package	Description
SY89420V	Ref.	PECL	3.3/5V	10MHz to 666MHz	PLCC-28	Dual Phase-Locked Loop w/Freq. Doubler Mode.
SY89421V	Ref.	PECL	3.3/5V	10MHz to 666MHz	SOIC-20	High-Performance Phase-Locked Loop.

Skew Management

Part Number	Input	Output	Voltage	Max. Freq. (GHz)	Package	Description
SY89295U	LVPECL/LVTTL	LVPECL	2.5/3.3V	1.5	TQFP/MLF-32	Programmable Delay.
SY89296U	LVPECL/LVTTL	LVPECL	2.5/3.3V	1.5	TQFP/MLF-32	Programmable Delay with Fine Tune Control.
SY89297U	ANY	CML	2.5V	1.6/3.2(Gbps)	MLF-24	5ps /Step Programmable Delay, Dual Channel.
SY55856U	CML	CML	2.5/3.3V	2.5	TQFP-32	Two Channel Delay Line.

Translators

Part Number	Input	Output	Voltage	Max. Freq. (GHz)	Package	Single/Dual
SY55851/A	PECL/LVPECL/CML	CML	2.5/3.3V	3	10-Pin MSOP	Single
SY55855V	ANY	LVDS	3.3/5V	0.75	10-Pin MSOP	Dual
SY55857L	ANY	LVPECL	3.3V	2.5	10-Pin MSOP	Dual
SY89222L	TTL	PECL	3.3V	0.4	MLF-8 (2mm x 2mm)	Dual
SY89223L	LVPECL	LVTTL	3.3V	0.16	MLF-8 (2mm x 2mm)	Dual
SY89321L	LVPECL	LVTTL	3.3V	0.275	MLF-8 (2mm x 2mm)	Single
SY89322V	LVTTL	LVPECL	3.3/5V	0.8	MLF-8 (2mm x 2mm)	Dual
SY89323L	LVPECL	LVTTL	3.3V	0.275	MLF-8 (2mm x 2mm)	Dual
SY89325V	ANY	LVDS	3.3V	0.750	MLF-8 (2mm x 2mm)	Single
SY89327L	ANY	LVPECL	3.3V	2.5	MLF-8 (2mm x 2mm)	Single
SY89328L	LVPECL/LVTTL	LVTTL/LVPECL	3.3V	0.275	MLF-8 (2mm x 2mm)	Single
SY89329V	LVTTL	LVPECL	3.3/5V	0.8	MLF-8 (2mm x 2mm)	Single
SY89464U	ANY	LVPECL	2.5/3.3V	2.0	MLF-44	Single
SY89465U	ANY	LVDS	2.5V	2.0	MLF-44	Single
SY89645L	LVC MOS/LVTTL	LVDS	3.3V	0.65	TSSOP-16	Single
SY89825U	LVDS/LVPECL	LVPECL	2.5/3.3V	1.0	TQFP-64	Single
SY89826L	LVDS/LVPECL	LVDS	3.3V	1.0	TQFP-64	Single
SY89827L	HSTL/LVPECL	HSTL	3.3V	0.5	TQFP-64	Dual
SY89828L	LVDS/LVPECL	LVDS	3.3V	1.0	TQFP-64	Dual
SY89829U	LVDS/LVPECL	LVPECL	2.5/3.3V	1.0	TQFP-64	Dual
SY89831U	LVPECL/HSTL/CML	LVPECL	2.5/3.3V	2.5	MLF-16 (3mm x 3mm)	Single
SY89832U	LVPECL/HSTL/LVDS/CML	LVDS	2.5V	2.5	MLF-16 (3mm x 3mm)	Single
SY89833L	LVPECL/HSTL/LVDS/CML	LVDS	3.3V	2.0	MLF-16 (3mm x 3mm)	Single
SY89834U	LVTTL/CMOS	LVPECL	2.5/3.3V	1.0	MLF-16 (3mm x 3mm)	Single

MLF-8 (2mm x 2mm) Solutions

Part Number	Equivalent	Input	Output	Voltage	Max. Freq. (GHz)	Description
SY58600U	—	ANY	CML	2.5V/3.3V	7	7GHz/10.7Gbps Differential Translator.
SY58601U	—	ANY	LVPECL	2.5V/3.3V	5	5GHz/5Gbps Differential Translator.
SY58602U	—	ANY	LVPECL	2.5V/3.3V	7	7GHz/10.7Gbps Differential Translator.
SY58603U	—	ANY	CML	2.5V/3.3V	2.5	Fail-Safe Input Buffers.
SY58604U	—	ANY	LVPECL	2.5V/3.3V	2.5	Fail-Safe Input Buffers.
SY58605U	—	ANY	LVDS	2.5V	2	Fail-Safe Input Buffers.
SY89206V	100EL16V	PECL	PECL	3.3/5V	1	Differential Receiver/Buffer.
SY89208V	100EP58V	PECL	PECL	3.3/5V	3	2:1 Multiplexer.
SY89216V	10EL16V	PECL	PECL	3.3/5V	1	Differential Receiver/Buffer.
SY89222L	100ELT22L	TTL	PECL	3.3V	0.40	Dual Differential Translator.
SY89223L	100ELT23L	LVPECL	LVTTTL	3.3V	0.16	Dual Differential Translator.
SY89250V	100EL16VC	PECL	PECL	3.3/5V	1	Enhanced Differential Receiver.
SY89306V	100EP16V	PECL	PECL	3.3/5V	2.5	Differential Receiver/Buffer.
SY89307V	100EP16VS	PECL	PECL	3.3/5V	2.5	Variable-out Differential Receiver.
SY89311U	100EP11U	PECL	PECL	2.5/3.3/5V	3	Differential 1:2 FOB.
SY89312V	100EP32V	PECL	PECL	3.3/5V	4	+2 Clock Generator.
SY89313V	100EP33V	PECL	PECL	3.3/5V	4	+4 Clock Generator.
SY89316V	10EP16V	PECL	PECL	3.3/5V	2.5	Differential Receiver/Buffer.
SY89321L	100EPT21L	LVPECL	LVTTTL	3.3V	0.275	Differential Translator.
SY89322V	100EPT22V	LVTTTL	LVPECL	3.3/5V	0.800	Dual Differential Translator.
SY89323L	100EPT23L	LVPECL	LVTTTL	3.3V	0.275	Dual Differential Translator.
SY89325V	55855V	ANYX	LVDS	3.3/5V	0.750	Differential Translator.
SY89327L	55857L	ANYX	LVPECL	3.3V	2.5	Differential Translator.
SY89328L	100EPT28L	LVTTTL/LVPECL	LVTTTL/LVPECL	3.3V	0.275	Dual Differential Translator.
SY89329V	100EPT20V	LVTTTL	LVPECL	3.3/5V	0.800	Differential Translator.

Communications Product Highlight — SY88993AL

Micrel Advantage

- Pin-to-pin compatible with other Micrel post amplifiers
- Consistent hysteresis performance
- Ideal drop-in replacement for SY88993V/AV

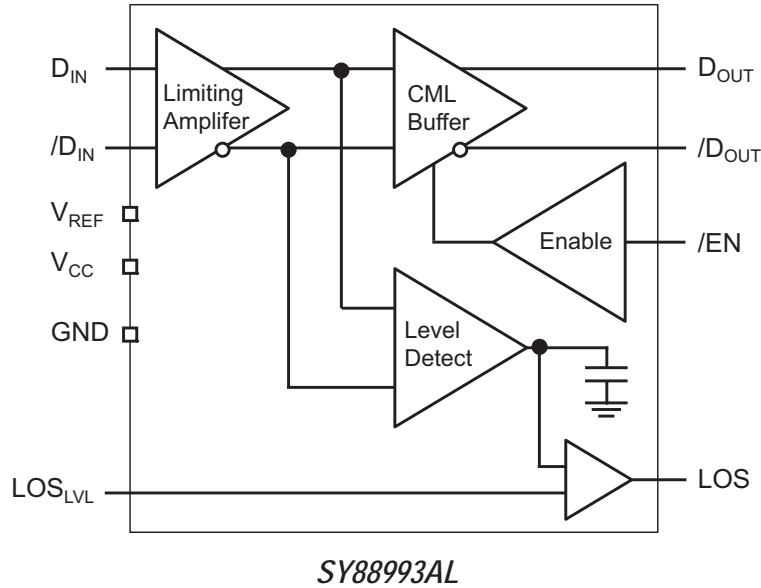

The SY88993AL limiting post amplifier, with its wide bandwidth, is ideal for use as a post amplifier in fiber-optic receivers with data rates up to 3.2Gbps. Signals as small as 4mVPP can be amplified to drive devices with CML inputs or AC-coupled PECL inputs. The SY88993AL generates a chatter-free Loss-of-Signal (LOS) open collector TTL output using an external resistor.

The SY88993AL incorporates a programmable level detect function to identify when the input signal has been lost. This information can be fed back to the /EN input of the device to maintain stability under loss of signal conditions. Using LOS_LVL pin the sensitivity of the level detect can be adjusted. The LOS_LVL voltage can be set by connecting a resistor divider between VCC and VREF.

Features

- Up to 3.2Gbps operation
- Low noise CML data outputs
- Chatter-Free LOS generation
- Open Collector TTL LOS output
- TTL /EN Input
- Differential PECL inputs for data
- Single 3.3V power supply
- Available in a tiny 10-pin (3mm x 3mm) MSOP

Applications

- PON
- SFP/SFF/GBIC optical transceivers
- Gigabit Ethernet
- 1X and 2X Fibre Channel
- SONET/SDH: OC 3/12/24/48 – STM 1/4/8/16
- Line driver and line receiver

Markets

- FTTX
- Datacom/Telecom

Communications Selection Guide

CDRs with Integrated Clock Synthesis

Part Number	Description	Function	Data Rate (Mbps)	Data Output Type	V _{CC}	Package	Eval. Board
SY69753AL ⁽¹⁾	Clock and Data Recovery	CDR	125-155	PECL	3.3V	EPAD-TQFP-32	Yes
SY69754AL	Clock and Data Recovery	CDR	622	PECL	3.3V	EPAD-TQFP-32	Yes
SY87700AL ⁽¹⁾	AnyRate [®] Clock and Data Recovery	CDR	32-208	PECL	3.3V	EPAD-TQFP-32, SOIC-28 ⁽²⁾	Yes
SY87701AL ⁽¹⁾	AnyRate [®] Clock and Data Recovery	CDR	28-1300	PECL	3.3V	EPAD-TQFP-32, SOIC-28 ⁽²⁾	Yes
SY87813L	AnyRate [®] Clock and Data Recovery with Differential Clock	CDR	28-1300	PECL	3.3V	EPAD-TQFP-32	Yes
SY87700V	AnyRate [®] Clock and Data Recovery	CDR	32-175	PECL	3.3/5V	EPAD-TQFP-32, SOIC-28 ⁽²⁾	Yes
SY87700L	AnyRate [®] Clock and Data Recovery	CDR	32-175	PECL	3.3V	EPAD-TQFP-32, SOIC-28 ⁽²⁾	Yes
SY87701V	AnyRate [®] Clock and Data Recovery	CDR	32-1250	PECL	3.3/5V	EPAD-TQFP-32, SOIC-28 ⁽²⁾	Yes
SY87701L	AnyRate [®] Clock and Data Recovery	CDR	32-1250	PECL	3.3V	EPAD-TQFP-32, SOIC-28 ⁽²⁾	Yes
SY87721L	AnyRate [®] Clock and Data Recovery	CDR	28-2700	CML/PECL	3.3V	EPAD-TQFP-64	Yes
SY69753L	Clock and Data Recovery	CDR	125-155	PECL	3.3V	EPAD-TQFP-64	Yes
SY69952	Clock Recovering Transceiver	Transceiver	51.84-155	PECL	5V	SOIC-28 ⁽²⁾	n/a

1. Run on 30% less I_{CC} than the SY69753L, SY87700V/L or SY87701V/L and are recommended for new designs.

2. 28-Pin SOIC is available, but not recommended for new designs.

Fiber Optic Transceiver ICs

Laser Drivers

Part Number	Description	Data Rate (Gbps)	Drive Current (mA)	V _{CC}	Package	Eval. Board
SY88212L	Laser Driver with APC and Power Monitoring	2.5	85	3.3V	MLF-24 (4mm x 4mm)	Yes
SY88216L	Burst Mode Laser Driver	2.5	85	3.3V	MLF-24 (4mm x 4mm)	Yes
SY88422L ⁽⁴⁾	Laser Driver with Integrated Bias	4.25	90	3.3V	MLF-16 (3mm x 3mm)	Yes
SY88722V	Laser Driver with Output Enable	0.622	30	3.3/5V	MSOP-10	Yes
SY88782L ⁽⁴⁾	High-Current, Low Power FP/DFB Laser Driver	1.25	90	3.3V	MLF-16 (3mm x 3mm)	n/a
SY88822V	Laser Driver with Output Enable	0.155	25	3.3/5V	MSOP-10	Yes
SY88902V	VCSEL Laser Driver with Output Enable	1.25	25	5V	MSOP-10	n/a
SY88912L	SONET/SDH Laser Driver	3.2	60	3.3V	MLF-16 (3mm x 3mm)	n/a
SY88922	SONET/SDH VCSEL Laser Driver	2.5	25	5V	MSOP-10 (3mm x 3mm)	n/a
SY88922V	SONET/SDH VCSEL Laser Driver	2.5	25	3.3/5V	MSOP-10 (3mm x 3mm)	n/a
SY88932L ⁽⁴⁾	VCSEL/FP/DFB Laser Driver	4.25	60	3.3V	MLF-16 (3mm x 3mm)	Yes
SY88982L ⁽⁴⁾	High-Current, Low Power FP/DFB Laser Driver	2.7	90	3.3V	MLF-16 (3mm x 3mm)	Yes
SY88992L ⁽⁴⁾	VCSEL Driver	4.25	25	3.3	MLF-16 (3mm x 3mm)	Yes
SY89307V ⁽⁴⁾	Output Swing Differential Receiver—VCSEL Driver	2.125	25	3.3V/5V	MLF-8 (2mm x 2mm)	Yes
SY100EL1003	Laser Driver with Output Enable	1.25	75	5V	SOIC-16	n/a
SY100EL16VS	Variable Output Swing Differential Receiver	1.25	25	3.3V/5V	MSOP-8 (3mm x 3mm), SOIC-8	n/a
SY100EP16VS	Variable Output Swing Differential Receiver	2.5	25	3.3V/5V	MSOP-8 (3mm x 3mm), SOIC-8	n/a

4. To be interfaced with MIC3001/2 controllers.

Controllers

Part Number	Description	Package
MIC3001	FOM Management IC with Internal Calibration	MLF-24 (4mm x 4mm)
MIC3002	FOM Management IC with Internal/External Calibration	MLF-24 (4mm x 4mm)

Post Amplifiers

Part Number	Data Rate (Gbps)	V _{CC}	LOS/SD	Input	Output	LOS/SD Gain	RC Time Constant	Hysteresis Typ. (dB)	Package
SY8893AL <i>New!</i>	1.25	3.3V	LOS (TTL)	PECL	PECL	1X	1X	5.6	MSOP-10
SY88147DL	1.25	3.3V	LOS (TTL)	PECL	PECL	4X	20X	3.5	MSOP-10
SY88149CL	1.25	3.3V	SD (TTL)	PECL	PECL	4X	1X	3.5	MSOP-10
SY88289AL ⁽¹⁾	3.2	3.3V	LOS (TTL)	PECL with internal 50Ω to V _{REF}	CML	1X	20X	3.5	MLF-16
SY88289CL ⁽¹⁾	3.2	3.3V	LOS (TTL)	PECL	CML	4X	20X	3.5	MLF-16
SY88289HL	3.2	3.3V	LOS (TTL)	PECL	CML	4X	20X	3.5	MLF-16
SY88303BL	3.2	3.3V	LOS (TTL)	PECL with internal 50Ω to V _{REF}	CML	0.5X	20X	3.5	EPAD-MSOP-10, MLF-16
SY88305BL	3.2	3.3V	SD (TTL)	PECL with internal 50Ω to V _{REF}	CML	0.5X	20X	3.5	EPAD-MSOP-10, MLF-16
SY88307BL	3.2	3.3V	LOS (TTL)	PECL with internal 50Ω to V _{REF}	PECL	0.5X	20X	3.5	EPAD-MSOP-10, MLF-16
SY88309BL	3.2	3.3V	SD (TTL)	PECL with internal 50Ω to V _{REF}	PECL	0.5X	20X	3.5	EPAD-MSOP-10, MLF-16
SY88313BL	3.2	3.3V	LOS (TTL)	PECL with internal 50Ω to V _{REF}	CML	1X	20X	3.5	EPAD-MSOP-10, MLF-16
SY88315BL	3.2	3.3V	SD (TTL)	PECL with internal 50Ω to V _{REF}	CML	1X	20X	3.5	EPAD-MSOP-10, MLF-16
SY88343BL	3.2	3.3V	LOS (TTL)	PECL with internal 50Ω to V _{REF}	CML	4X	20X	3.5	EPAD-MSOP-10, MLF-16
SY88343DL	3.2	3.3V	LOS (TTL)	PECL	CML	4X	20X	3.5	MLF-16
SY88343HL	3.2	3.3V	LOS (TTL)	PECL	CML	4X	20X	3.5	MLF-16
SY88345BL	3.2	3.3V	SD (TTL)	PECL with internal 50Ω to V _{REF}	CML	4X	20X	3.5	EPAD-MSOP-10, MLF-16
SY88347DL	3.2	3.3V	LOS (TTL)	PECL	PECL	4X	20X	3.5	MSOP-10
SY88353BL ⁽²⁾	3.2	3.3V	LOS (TTL)	PECL with internal 50Ω to V _{REF}	CML	1X	20X	3.5	MLF-16
SY88403BL	4.25	3.3V	LOS (TTL)	PECL with internal 50Ω to V _{REF}	CML	1X	20X	3.5	EPAD-MSOP-10, MLF-16
SY88713V	0.622	3.3V/5V	SD (PECL)	PECL	PECL	1X	1X	4.6	MSOP-10
SY88773V	3.2	3.3V/5V	LOS (TTL)	PECL	CML	1X	1X	4.6	EPAD-MSOP-10, MLF-16
SY88803V	0.155	3.3V/5V	LOS (TTL)	PECL	PECL	1X	1X	4.6	MSOP-10
SY88813V	0.155	3.3V/5V	SD (PECL)	PECL	PECL	1X	1X	4.6	MSOP-10
SY88843V	3.2	3.3V/5V	SD (TTL)	PECL with internal 50Ω to V _{REF}	CML	1X	1X	4.6	EPAD-MSOP-10, MLF-16
SY88903AL	1.25	3.3V	LOS (TTL)	PECL	PECL	4X	1X	3.5	MSOP-10
SY88903V	1.25	3.3V/5V	LOS (TTL)	PECL	PECL	1X	1X	4.6	MSOP-10
SY88913V	1.25	3.3V/5V	LOS (PECL)	PECL	PECL	1X	1X	4.6	MSOP-10
SY88923AV	3.2	3.3V/5V	LOS (TTL)	PECL	PECL	1X	1X	4.6	EPAD-MSOP-10, MSOP-10
SY88923V	2.5	3.3V/5V	LOS (TTL)	PECL	PECL	1X	1X	4.6	MSOP-10
SY88933AL	1.25	3.3V	SD (TTL)	PECL	PECL	4X	20X	3.5	MSOP-10
SY88933V	1.25	3.3V/5V	SD (TTL)	PECL	PECL	1X	1X	4.6	MSOP-10
SY88943V	2.5	3.3V/5V	SD (TTL)	PECL	PECL	1X	1X	4.6	MSOP-10
SY88953L ⁽²⁾	10.7	3.3V	SD & LOS (TTL)	CML	CML	1X	1X	4.6	MLF-16
SY88973V	3.2	3.3V/5V	LOS (TTL)	PECL with internal 50Ω to V _{REF}	CML	1X	1X	4.6	EPAD-MSOP-10, MLF-16
SY88973BL ⁽³⁾	3.2	3.3V	LOS (TTL)	PECL with internal 50Ω to V _{REF}	CML	1X	1X	4.6	MLF-16
SY88983V	3.2	3.3V/5V	SD (TTL)	PECL with internal 50Ω to V _{REF}	CML	1X	1X	4.6	EPAD-MSOP-10, MLF-16
SY88993AV	3.2	3.3V/5V	LOS (TTL)	PECL	CML	1X	1X	4.6	MSOP-10
SY88993V	3.2	3.3V/5V	LOS (TTL)	PECL	CML	1X	1X	5.6	MSOP-10

1. I/O compatible with ADN2891.

2. With Decision Threshold Adjustment: to correct input DC offset and optimize BER performance.

3. The pull-up resistor between LOS output and VCC is external.

Fractional N Synthesizers

Part Number	Description	Output Range	Input Ref. Osc.	Temperature	Package	Eval. Software
SY87729L	3.3V, AnyClock® 10MHz to 365MHz Fractional N Synthesizer	10MHz to 365MHz	27MHz	Industrial	TQFP-32	Yes
SY87739L	3.3V, Protocol Transparent 10MHz to 729MHz Fractional N Synthesizer	10MHz to 729MHz	27MHz	Industrial	TQFP-32	Yes

Multiplexer/Demultiplexer

Part Number	Function	Data Rate	Data Output	V _{CC}	Temperature	Conversion	Package
SY87724L	MUX and DeMUX	2.7Gbps	PECL	3.3V	Industrial	1:, 1:5, 1:8, 1:10, 4:1, 5:1, 8:1, 10:1	TQFP-80
SY87725L	SERDES	2.5Gbps	CML	3.3V	Industrial	1:4, 4:1	EPAD-TQFP-64
SY10100E445	DeMUX	2.5Gbps	PECL	5V	Commercial	1:4	LPCC-28
SY10100E446	MUX	1.6Gbps	PECL	5V	Commercial	4:1	LPCC-28

Ethernet Part Identification

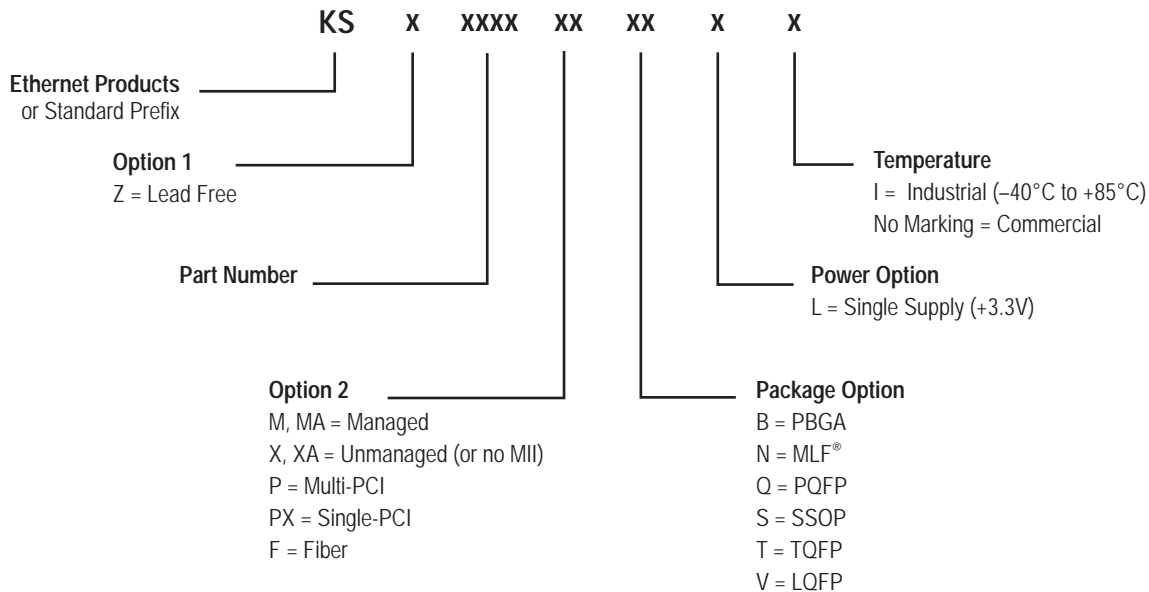

High Bandwidth Part Identification

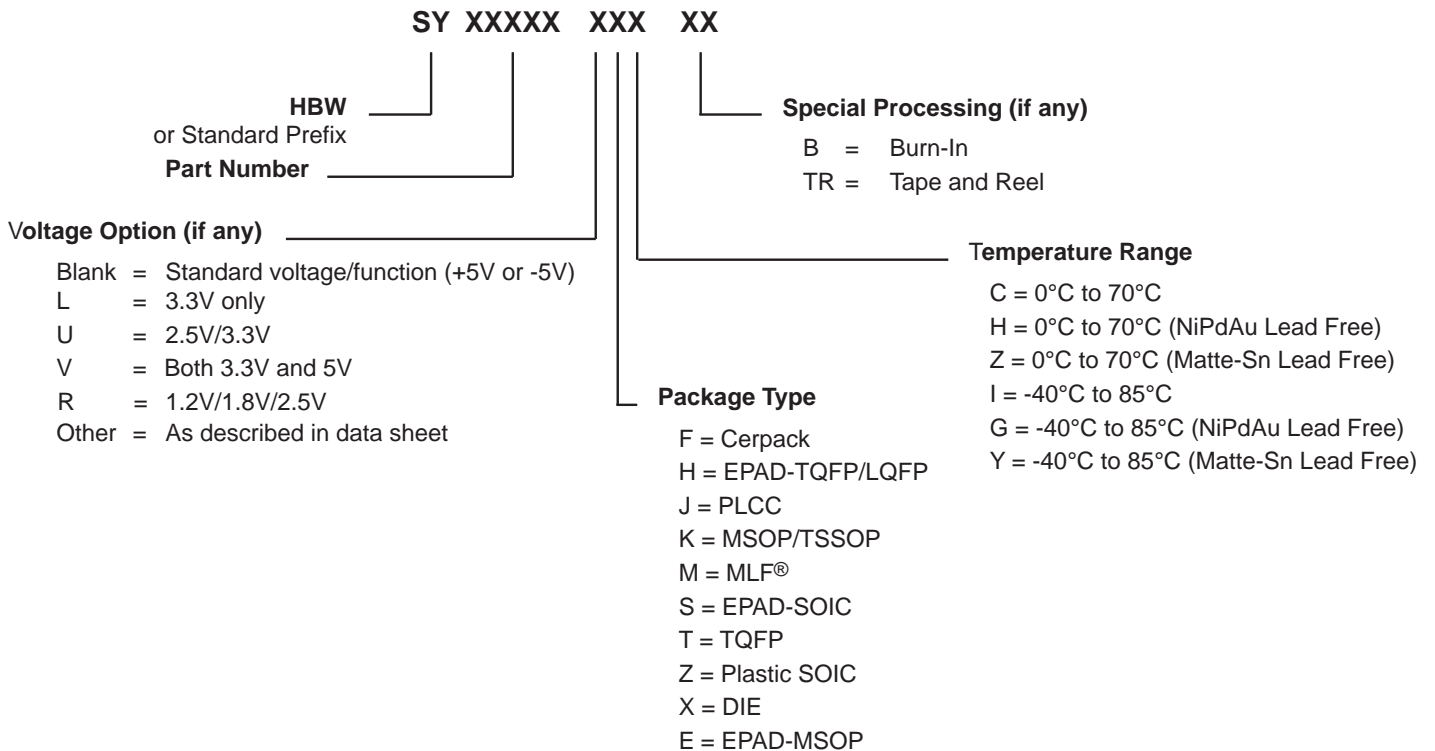

Analog Part Identification

Micrel Analog Standard

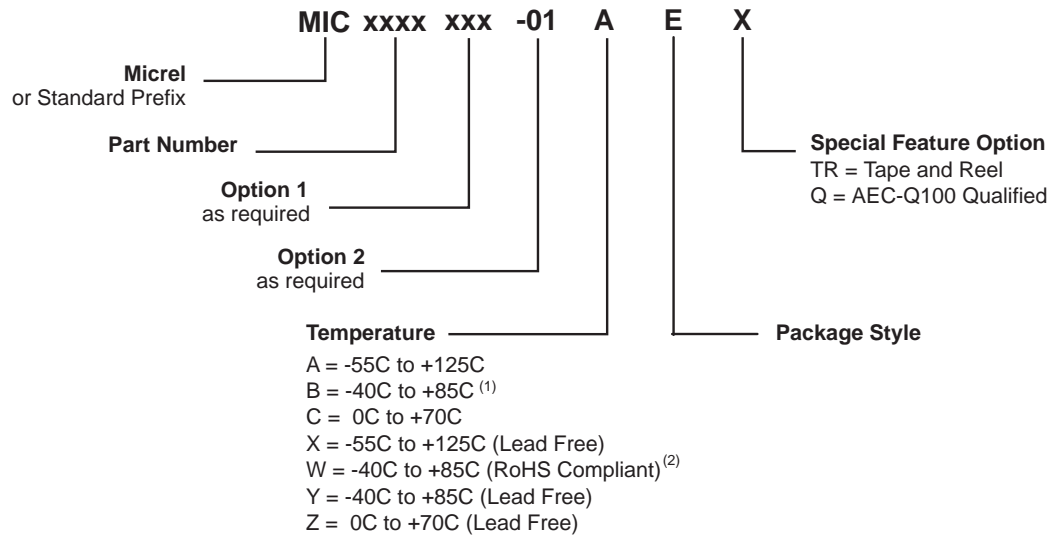

Notes:

- Typically, industrial grade power products rate the junction temperature up to +125C. Refer to the datasheet.
- Applicable to TO-220, TO-247, TO-263, SOT-223, SPAK packages using 85% lead plus lead alloy die attach material. Refer to the datasheet.

C3 = SC70-3	M = 150 mil SOIC	M6 = SOT-23-6	TS = TSSOP
C4 = SC70-4	ME = 150 mil EPAD-SOIC	M8 = SOT-23-8	TSE = EPAD-TSSOP
C5 = SC70-5	ML = MLF [®]	N = Plastic DIP	TQ = TQFP
C6 = SC70-6	MM = MSOP	QS = QSOP	TQE = EPAD-TQFP
D5 = Thin SOT	MME = EPAD-MSOP	QSE = EPAD-QSOP	U = TO-263
FL = MLF [®]	MT = Thin MLF [®]	R = SPAK	V = PLCC
HL = Hybrid MLF [®]	M3 = SOT-23-3	S = SOT-223	WM = 300 mil Wide SOIC
J = Ceramic DIP	M4 = SOT-143	SM = SSOP	WME = 300 mil Wide EPAD-SOIC
LQ = LQFP (Low Profile QFP)	M5 = SOT-23-5	T = TO-220	WT = TO-247

Industry Standard Voltage Supervisors

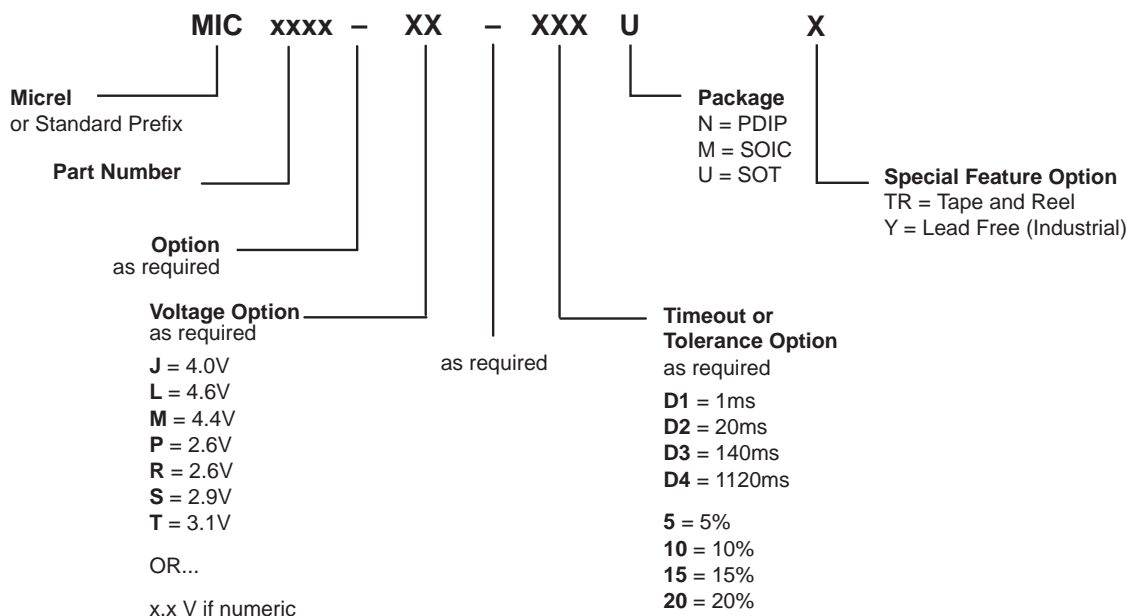

Worldwide Representatives and Distributors

Worldwide Sales Offices

Corporate HQ	2180 Fortune Dr.	San Jose, CA 95131 USA	Tel: (408) 944-0800	Fax: (408) 944-0970
Western USA	2180 Fortune Dr.	San Jose, CA 95131 USA	Tel: (408) 944-0800	Fax: (408) 944-0970
Central USA	2425 N. Central Expressway, Suite 351	Richardson, TX 57080 USA	Tel: (972) 393-2533	Fax: (408) 474-1210
Eastern USA	93 Branch St.	Medford, NJ 08055 USA	Tel: (609) 654-0078	Fax: (609) 654-0989
Latin America	2425 N. Central Expressway, Suite 351	Richardson, TX 57080 USA	Tel: (972) 393-2533	Fax: (408) 474-1210
China	Rm 601, Bldg. B, Int'l Chamber of Commerce Mansion, Fuhua Rd. 1, Futian Dist.	Shenzhen, P.R. China 518048	Tel: + 86-755-8302-7618	Fax: + 86-755-8302-7637
Japan	Queen's Tower A 14F, 2-3-1, Minato Mirai, Nishi-Ku, Yokohama-Shi	Kanagawa 220-6014, Japan	Tel: + 81-45-224-6616	Fax: + 81-45-224-6716
Korea	4th Fl., Manzo 2Bldg., 198-47, Gungnae-Dong, Bundang-Ku	Seongnam-City, Kyungki-do, 463-470 Korea	Tel: 82 (2) 538-2380	Fax: 82 (2) 538-2381
Singapore/India	7500A Beach Road, #07-324 The Plaza	Singapore 199591	Tel: + 65-6291-1318	Fax: + 65-6291-1332
Taiwan	4F, No. 43 Lane 188, Rueiguang Rd., Neihu District	Taipei, Taiwan, R.O.C.	Tel: + 866 (2) 8751-0600	Fax: +866 (2) 8751-0746
France/S. Europe	Les Laurentides – Batiment Ontario, 3, Avenue du Quebec	91140 Villebon sur Yvette, France	Tel: + 33 (0) 1.6092.4193	Fax: + 33 (0) 1.6092.4189
UK/EMEA	1st Floor, 3 Lockside Place, Mill Lane, Newbury, Berks	United Kingdom RG14 5QS	Tel: + 44 (1635) 524455	Fax: + 44 (1635) 524466
Sweden/Nordic	Nackrosvagen 16	169 37 Solna Sweden	Tel: +46 (8) 470 5950	Fax: + 46 (70) 572 7823

U.S. Sales Representatives

Rep.	Alliance Group One	640 Brooker Creek Blvd., Suite 415	Oldsmar, FL 34677	Tel: (813) 386-9000	Fax: (813) 386-9001	www.alliancegroup.com
Rep.	ATMI Sales	4900 SW Griffith Dr., Suite 253	Beaverton, OR 97035	Tel: (503) 643-8307	Fax: (503) 643-4364	www.atmisales.com
Rep.	ATMI Sales	8573 154th Ave., NE	Redmond, WA 98052	Tel: (425) 869-7636	Fax: (425) 869-9841	www.atmisales.com
Rep.	Avtek Associates, Inc.	8955 Guilford Rd., Suite 140	Columbia, MD 21046	Tel: (410) 381-4600	Fax: (410) 381-4700	
Rep.	B.P. Sales	2201 N. Central Expressway, Suite 255	Richardson, TX 75080	Tel: (972) 234-8438	Fax: (972) 437-0837	www.bpsales.com
Rep.	CK Associates, Inc.	8333 Clairemont Mesa Blvd., Suite 102	San Diego, CA 92111	Tel: (858) 279-0420	Fax: (858) 279-7650	www.ckassoc.com
Rep.	CTC Associates	57 Providence Highway	Norwood, MA 02062	Tel: (781) 320-1818	Fax: (781) 320-8282	www.ctcassociates.com
Rep.	Harwood Associates	25 High St.	Huntington, NY 11743	Tel: (631) 673-1900	Fax: (631) 673-2848	www.harwoodsales.com
Rep.	I-Squared Sales, Inc.	224 Airport Parkway, Suite 150	San Jose, CA 95110	Tel: (408) 988-3400	Fax: (408) 988-2079	www.isquared.com
Rep.	IRI of Kansas	101 Clark St., Suite 2000	St. Charles, MO 63301	Tel: (636) 916-1179	Fax: (636) 916-3381	www.irirep.com
Rep.	Northstar Technologies	8030 Old Cedar Ave., Suite 229	Bloomington, MN 55425	Tel: (952) 831-6777	Fax: (952) 831-7076	www.northstartech.com
Rep.	Quatra Associates, Inc.	2310 W. Ray Road, Suite 2	Chandler, AZ 85224-3516	Tel: (480) 753-5544	Fax: (480) 753-0640	www.quatraassociates.com
Rep.	Southbridge	650 Sun Temple Dr., Suite 101, P.O. Box 1246	Madison, AL 35758	Tel: (256) 461-1990	Fax: (256) 461-4047	www.southbridge.net
Rep.	Southbridge	426 Bethesda School Rd.	Lawrenceville, GA 30044	Tel: (770) 923-9883	Fax: (770) 923-2242	www.southbridge.net
Rep.	Southbridge	10940 Ravens Ridge Road, Suite 200	Raleigh, NC 27614	Tel: (919) 846-5888	Fax: (919) 846-0408	www.southbridge.net
Rep.	Strategic Sales, Inc.	27 Horseneck Rd, Suite 1E	Fairfield, NJ 08033	Tel: (973) 808-5060	Fax: (973) 808-5068	www.strategic-sales.com
Rep.	Sumer, Inc.	1675 Hicks Rd.	Rolling Meadows, IL 60008	Tel: (847) 991-8500	Fax: (847) 991-0474	www.sumer.com
Rep.	Technology Marketing Corp.	1526 East Greyhound Pass	Carmel, IN 46032	Tel: (317) 844-8462	Fax: (317) 573-5472	www.tmcc.com
Rep.	Technology Marketing Corp.	4630-10 West Jefferson Blvd.	Fort Wayne, IN 46804	Tel: (260) 432-5553	Fax: (260) 432-5555	www.tmcc.com
Rep.	Technology Marketing Corp.	2145 Bahama Rd.	Lexington, KY 40509	Tel: (859) 253-1808	Fax: (859) 253-1662	www.tmcc.com
Rep.	Technology Marketing Corp.	7138 Hillside Dr.	West Bloomfield, MI 48322	Tel: (248) 592-0814	Fax: (248) 592-0818	www.tmcc.com
Rep.	Technology Marketing Corp.	7800 Cooper Rd., Suite 205	Cincinnati, OH 45242	Tel: (513) 984-6720	Fax: (513) 936-6515	www.tmcc.com
Rep.	Technology Marketing Corp.	One Independence Pl., 4807 Rockside Rd., Ste. 200	Cleveland, OH 44131	Tel: (216) 520-0150	Fax: (216) 520-0190	www.tmcc.com
Rep.	Thom Luke Sales, Inc.	1048 N. 44th Street, Suite 245	Phoenix, AZ 85008	Tel: (602) 214-0000	Fax: (602) 626-3515	www.thomlukesales.com
Rep.	Thom Luke Sales, Inc.	9000 E. Nichols Ave., Suite 115	Englewood, CO 80112	Tel: (303) 649-9717	Fax: (303) 649-9719	www.thomlukesales.com
Rep.	Thom Luke Sales, Inc.	31 West 780 South	Centerville, UT 84014	Tel: (801) 298-5649	Fax: (801) 296-2934	www.thomlukesales.com

U.S. Distributors (Corporate Offices)

Dist.	Arrow Electronics Inc.	50 Marcus Dr.	Melville, NY 11747-4201	Tel: (800) 777-2776	Fax: (631) 847-2222	www.arrow.com
Dist.	Digi-Key Corporation	701 Brooks Ave. South	Thief River Falls, MN 56701	Tel: (800) 344-4539	Fax: (216) 681-3380	www.digi-key.com
Dist.	Future Electronics	237 Hymus Blvd.	Point-Claire, Quebec H9R 5C7 Canada	Tel: (514) 457-3004	Fax: (514) 457-4912	www.futureelectronics.com
Dist.	Nu Horizons Electronics	70 Maxes Rd.	Melville, NY 11747	Tel: (800) 747-6846	Fax: (631) 396-5050	www.nuhorizons.com
Die Dist.	Chip Supply, Inc.	7725 Orange Blossom Trail	Orlando, FL 32810	Tel: (407) 298-7100	Fax: (407) 290-0164	www.chipsupply.com
Die Dist.	ES Components, Inc.	108 Pratts Junction Rd.	Sterling, MA 01564	Tel: (978) 422-7641	Fax: (978) 422-0011	www.escomponents.com

International Sales Representatives and Distributors

Australia			
Dist.	Arrow Asia PAC Ltd.	Tel: 852 2484 2484	www.arrowasia.com
Dist.	Braemac Pty. Ltd.	Tel: 61 (2) 9550-6600	www.braemac.com
Dist.	Future Electronics	Tel: 61 (3) 9899-7944	www.futureelectronics.com
Austria			
Dist.	Future Electronics	Tel: + 43 2233 55366	www.futureelectronics.com
Dist.	SASCO Holz Vienna	Tel: + 43 (0) 177 99 60 44-0	www.sascoh Holz.com
Belgium			
Rep.	Nijkerk Electronics N.V.	Tel: + 33 (3) 544 70 66	www.nijkerk.com
Dist.	Future Electronics	Tel: + 3 (9) 340 52 70	www.futureelectronics.com
Dist.	SASCO Holz Brussels	Tel: + 32 (0) 277 19 71-50	www.sascoh Holz.com
Brazil			
Dist.	Future Electronics	Tel: + 55 (19) 3737-4100	www.futureelectronics.com
Bulgaria			
Dist.	Future Electronics	Tel: 852-2484-2484	www.futureelectronics.com
Canada-AB			
Rep.	GMA	Tel: (403) 275-7178	www.gmarep.com
Dist.	Active Electronics	Tel: (403) 291-5626	www.active123.com
Dist.	Arrow Electronics Inc.	Tel: (403) 259-6817	www.arrow.com
Dist.	Future Electronics	Tel: (403) 291-3443	www.futureelectronics.com
Canada-BC			
Rep.	GMA	Tel: (603) 303-0044	www.gmarep.com
Dist.	Arrow Electronics Inc.	Tel: (604) 421-2333	www.arrow.com
Dist.	Future Electronics	Tel: (604) 294-1166	www.futureelectronics.com
Canada-East			
Die Dist.	ES Components, Inc.	Tel: (403) 291-3443	www.escomponents.com
Canada-MB			
Rep.	GMA	Tel: (403) 275-7178	www.gmarep.com
Dist.	Arrow Electronics Inc.	Tel: (204) 632-1260	www.arrow.com
Dist.	Future Electronics	Tel: (204) 944-1446	www.futureelectronics.com
Canada-MP			
Rep.	GMA	Tel: (905) 671-8111	www.gmarep.com
Canada-ON			
Rep.	GMA	Tel: (613) 820-3822	www.gmarep.com
Dist.	Active Electronics	Tel: (905) 238-8825	www.active123.com
Dist.	Arrow Electronics Inc.	Tel: (613) 271-8200	www.arrow.com
Dist.	Future Electronics	Tel: (613) 727-1800	www.futureelectronics.com
Dist.	Newark Electronics	Tel: (519) 685-4280	www.newarkelectronics.com
Dist.	Nu Horizons Electronics	Tel: (905) 761-1911	www.nuhorizons.com
Canada-QC			
Rep.	GMA	Tel: (514) 335-9572	www.gmarep.com
Dist.	Active Electronics	Tel: (418) 682-5775	www.active123.com
Dist.	Arrow Electronics Inc.	Tel: (514) 421-7411	www.arrow.com
Dist.	Future Electronics	Tel: (514) 694-7710	www.futureelectronics.com
Dist.	Newark Electronics	Tel: (514) 738-4488	www.newarkelectronics.com
China			
DRep.	Amtronix, Inc.-Beijing	Tel: + 86 (10) 8499-0974	www.amtronixhk.com
DRep.	Amtronix, Inc.-Shenzhen	Tel: + 86 (755) 8356-6850	www.amtronixhk.com
DRep.	Amtronix, Inc.-ChongQing	Tel: + 86 (23) 6861-6198	www.amtronixhk.com
DRep.	Milli-Tech Electronics Ltd.	Tel: + 86 (755) 8384-9510	www.millitech.com
DRep.	RTI Holdings Ltd.	Tel: 852-2795-7421	www.rti.com.hk
Dist.	Arrow Asia PAC Ltd.	Tel: 852-2484-2484	www.arrowasia.com
Dist.	Comtech Group, Inc.	Tel: + 86 (755) 2674-3210	www.comp-techgroup.com
Dist.	Future Electronics-Beijing	Tel: + 86 (10) 6418-2335	www.futureelectronics.com
Dist.	Future Electronics-Chengdu	Tel: + 86 (28) 8545-4789	www.futureelectronics.com
Dist.	Future Electronics-Guangzhou	Tel: + 86 (20) 8363-4927	www.futureelectronics.com
Dist.	Future Electronics-Nanjing	Tel: + 86 (25) 4710047	www.futureelectronics.com
Dist.	Future Electronics-Qingdao	Tel: + 86 (532) 502-6035	www.futureelectronics.com
Dist.	Future Electronics-Tianjin	Tel: + 86 (22) 2302-2520	www.futureelectronics.com
Dist.	Future Electronics-Xiamen	Tel: + 86 (592) 239-8230	www.futureelectronics.com
Dist.	Future Electronics-Shanghai	Tel: + 86 (21) 6255-3980	www.futureelectronics.com
Dist.	Future Electronics-Shenzhen	Tel: + 86 (755) 8366-9286	www.futureelectronics.com
Dist.	Secom Telecom Co.-Shenzhen	Tel: + 86 (755) 2515-5888	www.secomtel.com
Dist.	Secom Telecom Co.-Shanghai	Tel: + 86 (21) 6212-1097	www.secomtel.com
Dist.	Secom Telecom Co.-Nanjing	Tel: + 86 (25) 8445-3616	www.secomtel.com
Dist.	Secom Telecom Co.-Chengdu	Tel: + 86 (28) 8298-1751	www.secomtel.com
Dist.	Secom Telecom Co.-Beijing	Tel: + 86 (10) 6235-8916	www.secomtel.com
Dist.	Secom Telecom Co.-Xi'an	Tel: + 86 (29) 8832-3435	www.secomtel.com
Dist.	Synnex Pacific, Ltd.-Shenzhen	Tel: + 86 (755) 8334-2722	www.synnex.com
Dist.	Synnex Pacific, Ltd.-Beijing	Tel: + 86 (10) 8225-3522	www.synnex.com
Dist.	Synnex Pacific, Ltd.-Shanghai	Tel: + 86 (21) 62216298	www.synnex.com
Rep.	Galaxy Far East Corp.-Beijing	Tel: + 86 (10) 6495-6484	www.gfec.com.tw
Rep.	Galaxy Far East Corp.-Shenzhen	Tel: + 86 (755) 8399-8903	www.gfec.com.tw
Rep.	Galaxy Far East Corp.-Chengdu	Tel: + 86 (28) 8554-8390	www.gfec.com.tw
Rep.	Galaxy Far East Corp.-Wuhan	Tel: + 86 (27) 8730-6822	www.gfec.com.tw
Rep.	Lestina International Ltd.-Beijing	Tel: + 86 (10) 6210-1671	www.lestina.com
Rep.	Lestina International Ltd.-Chengdu	Tel: + 86 (28) 514-4000	www.lestina.com
Rep.	Lestina International Ltd.-Shanghai	Tel: + 86 (21) 6464-6969	www.lestina.com
Rep.	Lestina International Ltd.-Shenzhen	Tel: + 86 (755) 8343-8383	www.lestina.com
SRep.	Tekall Technologies Co.-Shenzhen (RF products only)	Tel: + 86 (755) 8343-8383	www.tekall.com
SRep.	Tekall Technologies Co.-Beijing (RF products only)	Tel: + 86 (10) 6872-7716	www.tekall.com
SRep.	Tekall Technologies Co.-Wuhan (RF products only)	Tel: + 86 (27) 8385-8150	www.tekall.com
Czech Republic			
Dist.	SASCO Holz-Prague	Tel: + 420 271 001 470	www.sascoh Holz.com
Denmark			
Dist.	Arrow Denmark	Tel: + 45 70 10 22 11	www.arrow.com
Dist.	Arrow Nordic Components AB	Tel: + 44 1279 441144	www.arrowne.com
Dist.	Future Electronics	Tel: + 45 76 40 87 64	www.futureelectronics.com
Estonia			
Dist.	Arrow Nordic Components AB	Tel: + 44 1279 441144	www.arrowne.com
Dist.	Arrow Estonia	Tel: + 372 677 42 50	www.arrow.com
Dist.	Future Electronics	Tel: + 372 614 3201	www.futureelectronics.com
Die Dist.	Chip Supply, Inc.	Tel: + 44 (1616) 336627	www.chipsupply.com
Europe			
Die Dist.	Die Technology, Ltd.	Tel: + 44 (0) 1603 788 967	www.dietechnology.com
Dist.	Arrow Finland	Tel: + 358 (9) 47 66 60	www.arrowne.com
Dist.	Arrow Nordic Components AB	Tel: + 44 1279 441144	www.arrowne.com
Finland			
Dist.	Future Electronics	Tel: + 358 (9) 525 9950	www.futureelectronics.com
France			
Dist.	Arrow France-Rungis	Tel: + 33 (1) 56.30.24.25	www.arrow.com
Dist.	Arrow France-Lyon	Tel: + 33 (4) 72.78.14.80	www.arrow.com
Dist.	Arrow France-Toulouse	Tel: + 33 (5) 34.60.46.70	www.arrow.com
Dist.	Arrow France-Rennes	Tel: + 33 (2) 99.51.51.51	www.arrow.com
Dist.	Arrow France-Strasbourg	Tel: + 33 (3) 88.65.82.82	www.arrow.com
Dist.	Arrow France-Bordeaux	Tel: + 33 (5) 56.13.71.80	www.arrow.com
Dist.	Arrow France-Lillie	Tel: + 33 (3) 20.05.10.56	www.arrow.com
Dist.	Arrow France-Grenoble	Tel: + 33 (4) 76.59.43.00	www.arrow.com
Dist.	Attitude Electronics S.A.S.	Tel: + 33 (1) 46.49.30.30	www.attitude-electronics.com
Dist.	Future Electronics-Paris	Tel: + 33 (1) 69.82.11.11	www.futureelectronics.com
Dist.	Future Electronics-Lyon	Tel: + 33 (4) 72.15.86.00	www.futureelectronics.com
Dist.	Future Electronics-Rennes	Tel: + 33 (2) 23.45.60.80	www.futureelectronics.com
Dist.	Future Electronics-Toulouse	Tel: + 33 (5) 62.74.72.40	www.futureelectronics.com
Die Dist.	Die Technology, Ltd.	Tel: + 44 (0) 1603 788967	www.dietechnology.co
Dist.	Tekelec Europe-Rungis	Tel: + 33 (1) 56.30.24.25	www.tekelec.com

Germany

Rep.	Activerep Electronic GmbH	Tel: + 49 7252-537-101	www.activerep.com
Dist.	Dacom Sued GmbH Freisinger Strasse 13 85737 Ismaning	Tel: + 49 (89) 96 48 80	
Dist.	Future Electronics Deut.–Ismaning	Tel: + 49 (89) 95 72 70	www.futureelectronics.com
Dist.	Future Electronics Deut.–Luenen	Tel: + 49 (231) 975 048 0	www.futureelectronics.com
Dist.	Future Electronics Deut.–Erfurt	Tel: + 49 (361) 42 087 0	www.futureelectronics.com
Dist.	Future Electronics Deut.–Idstein	Tel: + 49 (612) 69 321 0	www.futureelectronics.com
Dist.	Future Electronics Deut.–Hamburg	Tel: + 49 (40) 547277 0	www.futureelectronics.com
Dist.	Future Electronics Deut.–Muenchingen	Tel: + 49 (711) 830 830	www.futureelectronics.com
Dist.	SASCO Holz–Berlin	Tel: + 49 (0) 30/34 99 24 0	www.sascoholtz.com
Dist.	SASCO Holz–Dortmund	Tel: + 49 (0) 2 31/91 72 00-0	www.sascoholtz.com
Dist.	SASCO Holz–Frankfurt	Tel: + 49 (0) 61 03/93 73-0	www.sascoholtz.com
Dist.	SASCO Holz–Hamburg	Tel: + 49 (0) 40/52 87 46-0	www.sascoholtz.com
Dist.	SASCO Holz–Munich	Tel: + 49 (0) 89/46 11-2 11	www.sascoholtz.com
Dist.	SASCO Holz–Nuremberg	Tel: + 49 (0) 91 22/87 69-0	www.sascoholtz.com
Dist.	SASCO Holz–Stuttgart North	Tel: + 49 (0) 71 42/9 60-0	www.sascoholtz.com
Dist.	SASCO Holz–Stuttgart South	Tel: + 49 (0) 70 21/9 83 90	www.sascoholtz.com

Hong Kong

Rep.	Lestina International Ltd.	Tel: + (852) 2735-1736	www.lestina.com
DRep.	RTI Holdings Ltd.	Tel: + (852) 2795-7421	www.rti.com.hk
Dist.	Arrow Asia PAC Ltd.	Tel: + (852) 2484 2484	www.arrowasia.com
Dist.	Future Electronics	Tel: + (852) 2420-6238	www.futureelectronics.com

Hungary

Dist.	SASCO Holz–Budapest	Tel: + 36 (0) 1/28 87 30-0	www.sascoholtz.com
Dist.	Future Electronics	Tel: + 36 (1) 224 0510	www.futureelectronics.com

India

Rep.	Syatron Marketing Private, Ltd.	Tel: + 91-80-25591031	www.syatron
Dist.	Arrow Asia PAC Ltd.	Tel: + (852) 2484-2484	www.arrowasia.com
Dist.	Arrow Electronics India–Bangalore	Tel: + 91 (80) 51353800	www.arrowasia.com.hk
Dist.	Arrow Electronics India–New Delhi	Tel: + 91 (11) 25784629	www.arrowasia.com.hk
Dist.	Arrow Electronics India–Bombay	Tel: + 91 (22) 56925196	www.arrowasia.com.hk
Dist.	Arrow Electronics India–Hyderabad	Tel: + 91 (40) 55774146	www.arrowasia.com.hk
Dist.	Future Electronics–Bangalore	Tel: + 91 (80) 558-7885	www.futureelectronics.com
Dist.	Future Electronics–Bombay	Tel: + 91 (22) 570-2745	www.futureelectronics.com
Dist.	Future Electronics–New Delhi	Tel: + 91 (11) 646-1414	www.futureelectronics.com

Indonesia

Dist.	Arrow Asia PAC Ltd.	Tel: + (852) 2484-2484	www.arrowasia.com
Dist.	Weikeng Technology Pte. Ltd.	Tel: + 886-2-2659-0202	www.weikeng.com

Ireland

Dist.	Arrow Nordic Components AB	Tel: + 44 1279 441144	www.arrowne.com
Dist.	Future Electronics Ltd.	Tel: + 353 (65) 41 330	www.futureelectronics.com

Israel

Rep.	2BePresent Ltd.	Tel: + 972 (77) 7505017	www.2bepresent.com
Dist.	Future Electronics	Tel: + 972 (9) 970 1414	www.futureelectronics.com
Dist.	Gitronics Ltd.	Tel: + 972 (3) 927-4738	www.gitronics.co.il

Italy

Rep.	Aertronica S.r.l.	Tel: + 39 (039) 230 2240	www.aertronica.it
Dist.	Claitron	Tel: + 39 (02) 661431	www.claitron-lasi.it
Dist.	Future Electronics Srl–Milan	Tel: + 39 (02) 660 941	www.futureelectronics.com
Dist.	Future Electronics Srl–Bologna	Tel: + 39 (51) 613 6711	www.futureelectronics.com
Dist.	Future Electronics Srl–Padova	Tel: + 39 (49) 899 20111	www.futureelectronics.com

Japan

Rep.	Hakuto Co. Ltd.–Aichi	Tel: + 81 (52) 204-8910	www.hakuto.co.jp
Rep.	Hakuto Co. Ltd.–Ehime	Tel: + 81 (89) 931-8910	www.hakuto.co.jp
Rep.	Hakuto Co. Ltd.–Fukoka	Tel: + 81 (92) 431-5330	www.hakuto.co.jp
Rep.	Hakuto Co. Ltd.–Hoygo	Tel: + 81 (72) 784-8910	www.hakuto.co.jp
Rep.	Hakuto Co. Ltd.–Tokyo	Tel: + 81 (3) 3355-7629	www.hakuto.co.jp
Dist.	Future Electronics–Osaka	Tel: + 81 (6) 6221-2201	www.futureelectronics.com
Dist.	Future Electronics–Tokyo	Tel: + 81 (45) 224-2155	www.futureelectronics.com
Dist.	Ryosan Company Ltd.	Tel: + 81 (3) 862-2635	www.ryosan.co.jp
Dist.	Uni-Electronics, Inc.	Tel: + 81 (3) 3347-8878	www.uni-elec.co.jp

Korea

Rep.	Brainworld Co. Ltd.	Tel: + 82 (2) 974-2647	www.brainworld.co.kr
Rep.	GenCore Technology Co., Ltd.	Tel: + 82 (2) 3463-0040	www.bec.co.kr
DRep.	Progate Technology Ltd.	Tel: + 82 (31) 707-3274	www.progate.co.kr

Latvia

Dist.	Arrow Latvia	Tel: + 371 7311490	www.arrownordic.com
Dist.	Arrow Nordic Components AB	Tel: + 44 1279 441144	www.arrownordic.com

Lithuania

Dist.	Arrow Lithuania	Tel: + 370-37-759015	www.arrownordic.com
Dist.	Future Electronics	Tel: + 370-37-408482	www.futureelectronics.com

Malaysia

Dist.	Arrow Asia PAC Ltd.	Tel: + (852) 2484 2484	www.arrowasia.com
Dist.	Future Electronics-Kuala Lumpur	Tel: + 60 (3) 703-7133	www.futureelectronics.com
Dist.	Future Electronics-Penang	Tel: + 60 (4) 227-7213	www.futureelectronics.com
Dist.	JAG Components Sdn Bhd	Tel: + 60 (4) 6469488	www.jagcomponents.com
Dist.	Weikeng Technology Pte. Ltd.	Tel: + 886-2-2659-0202	www.weikeng.com

Mexico

Rep.	BP Electronica S.A. DEC V	Tel: + (972) 234-8438	www.bpsales.com
Dist.	Future Electronics-Mexico	Tel: + 52 (33) 3122-00-43	www.futureelectronics.com

Netherlands

Rep.	Nijkerk Electronics B.V.	Tel: + 31 (0) 20 504 14 24	www.nijkerk.com
Dist.	Future Electronics	Tel: + 31 76 5444 888	www.futureelectronics.com
Dist.	SASCO Holz Utrecht	Tel: + 31 (0) 30/63 91 21-5	www.sascoholtz.com

New Zealand

Dist.	Arrow Asia PAC Ltd.	Tel: + (852) 2484 2484	www.arrowasia.com
Dist.	Braemac Pty. Ltd.	Tel: + 61 (2) 9550-6600	www.braemac.com
Dist.	Future Electronics	Tel: + 64 (3) 9823256	www.futureelectronics.com

North America

Die Dist.	Chip Supply, Inc.	Tel: + 1 407-298-7100	www.chipsupply.com
-----------	-------------------	-----------------------	--------------------

Norway

Dist.	Arrow Norway	Tel: + 47 52763000	www.arrowne.com
Dist.	Arrow Nordic Components AB	Tel: + 44 1279 441144	www.arrowne.com
Dist.	Future Electronics A/S	Tel: + 47 (22) 90 5800	www.futureelectronics.com

Philippines

Dist.	Arrow Asia PAC Ltd.	Tel: + (852) 2484 2484	www.arrowasia.com
Dist.	Future Electronics-Philippines	Tel: + 63 (2) 807-5092/3512	www.futureelectronics.com
Dist.	Weikeng Technology Pte. Ltd.	Tel: + 886-2-2659-0202	www.weikeng.com

Poland

Dist.	Future Electronics	Tel: + 48 (22) 618 9202	www.futureelectronics.com
Dist.	SASCO Holz Warsaw	Tel: + 48 (0) 22/5 58 82 82	www.sascoholtz.com

Portugal

Dist.	Arrow-Iberia	Tel: + 34 (91) 304 3040	www.arrowiberia.com
-------	--------------	-------------------------	---------------------

Puerto Rico

Die Dist.	ES Components, Inc.	Tel: + 1 978-422-7641	www.escomponents.com
-----------	---------------------	-----------------------	----------------------

Russia

Dist.	Eltech, Ltd.	Tel: + 7 812-327-9090	www.eltek.co.il
Dist.	SASCO Holz Moscow	Tel: + 7 49 59 26 55 97	www.sascoholtz.com

Singapore

Dist.	Arrow Asia PAC Ltd.	Tel: + (852) 2484 2484	www.arrowasia.com
Dist.	Hynetic Electronics	Tel: + 91 (80) 652-0852	www.hynetic.com
Dist.	JAG Components Pte. Ltd.	Tel: + (65) 6749 5663	www.jagcomponents.com
Dist.	Future Electronics Ltd.	Tel: + (65) 6479 1300	www.futureelectronics.com
Dist.	Weikeng Technology Pte. Ltd.	Tel: + 886-2-2659-0202	www.weikeng.com

South Africa

Rep.	MB Silicon Systems Ltd.	Tel: + 27 (11) 728 4757	www.mbsiliconsystems.co.za/
------	-------------------------	-------------------------	-----------------------------

South America

Rep. BP & M Ltd.
689 West Renner Rd., Suite 101
Richardson, TX 75070, USA
Tel: + 1 972-234-8438

South Korea

Dist. Arrow Asia PAC Ltd. Tel: + (852) 2484 2484 www.arrowasia.com

Spain

Dist. Arrow-Iberia Tel: + 34 (91) 304 3040 www.arrowiberia.com
Dist. Future Electronics Tel: + 34 (91) 721 4270 www.futureelectronics.com

Sweden

Dist. Arrow Nordic Components-Kista Tel: + 46 8 562 655 00 www.arrownordic.com
Dist. Arrow Nordic Components-Vas. Frolunda Tel: + 46 31 7219800 www.arrownordic.com
Dist. Arrow Nordic Components-Skelleftea Tel: + 46 910 715 360 www.arrownordic.com
Dist. Future Electronics AB-Kungsbacka Tel: + 46 300 30300 www.futureelectronics.com
Dist. Future Electronics AB-Svedala Tel: + 46 (40) 406990 www.futureelectronics.com
Dist. Future Electronics AB-Solna Tel: + 46 (8) 624 8800 www.futureelectronics.com

Switzerland

Dist. SASCO Holz-Yverdon Tel: + 41 (0) 24/4 47 01 41 www.sascoholz.com
Dist. SASCO Holz-Zurich Tel: + 41 (0) 44/81 76 28-0 www.sascoholz.com

Taiwan, R.O.C.

Dist. Arrow Asia PAC Ltd. Tel: + (852) 2484 2484 www.arrowasia.com
Dist. Future Electronics-Hsin Chu Tel: + 886 (3) 574-4646 www.futureelectronics.com
Dist. Future Electronics-Taipei Tel: + 886 (2) 8861-5288 www.futureelectronics.com
Dist. Galaxy Far East Corp.-Hsinchu Tel: + 886 (3) 578-6766 www.gfec.com.tw
Dist. Galaxy Far East Corp.-Kaohsiung Tel: + 886 (7) 338-0559 www.gfec.com.tw
Dist. Galaxy Far East Corp.-Taipei Tel: + 886 (2) 8913-2200 www.gfec.com.tw
Dist. Techmosa International Corp. Tel: + 886 (2) 8226-7698 www.techmosa.com.tw
Dist. Weikeng Technology Pte. Ltd. Tel: + 886 (2) 2659-0202 www.weikeng.com

Thailand

Dist. Arrow Asia PAC Ltd. Tel: + (852) 2484 2484 www.arrowasia.com
Dist. Future Electronics-Thailand Tel: + 662-361-8400 www.futureelectronics.com
Dist. JAG Components Thailand Co. Ltd. Tel: + 662-720-4302 www.jagcomponents.com
Dist. Weikeng Technology Pte. Ltd. Tel: + 886 (2) 2659-0202 www.weikeng.com

Turkey

Rep. 2BePresent Ltd. Tel: + 972 (77) 7505017 www.2bepresent.com
Dist. Future Electronics Tel: + 90 (216) 445 8700 www.futureelectronics.com

UK

Dist. Arrow UK Tel: + 44 1279 441144 www.arrowuk.com
Dist. Future Electronics Ltd. Tel: + 44 (1753) 763000 www.futureelectronics.com

Ukraine

Dist. SASCO Holz Kiev Tel: + 38 06 72 31 09 50 www.sascoholz.com

Vietnam

Dist. Arrow Asia PAC Ltd. Tel: + (852) 2484 2484 www.arrowasia.com



2180 Fortune Dr. • San Jose, CA 95131 • USA

Tel: 1.408.944.0800

Fax: 1.408-955.1666

www.micrel.com