

# LOW COST, LOW DISTORTION LINE MATCHING TRANSFORMER

# P3356

## Features

- \* Low Cost
- \* Low Distortion
- \* 12.6mm (0.5") Seated Height
- \* Industry Standard Pinout
- \* IEC 950, UL 1950 and EN 60950 Certified
- \* UL Recognized Component
- \* BAPT Certificate of Recognition
- \* Extended Frequency Response
- \* Flat TX and RX Responses
- \* Simple Matching
- \* Low Insertion Loss
- \* High Thermal Stability

## Applications

- \* V.90 and V.92 Modems
- \* V.34 Modems
- \* Fax Machines
- \* Instrumentation

## DESCRIPTION

P3356 is intended for V.90 and V.92 (56kbps) modems and other high-speed applications where ultra-low distortion at moderate power levels and very low voiceband frequencies is required at a most competitive price.

P3356 uses patented design and construction methods to achieve excellent signal performance and safety isolation to international standards at truly low cost, making it the component of choice for high-speed data applications throughout the world. P3356 is certified to IEC 950, EN 60950, EN 41003, and CAN/CSA C22.2 No. 950-95/UL1950. P3356 is a UL Recognized Component, and is supported by a BAPT Certificate of Recognition and an IEC CB Test Certificate.

P3356 has exceptionally flat frequency response from 30Hz to 10kHz, a 3dB bandwidth of over 50kHz and requires only the very simplest of matching to achieve good return loss and transhybrid loss across the voiceband, with very low levels of signal distortion at signal frequencies as low as 150Hz.

P3356 also exhibits stable characteristics over its full operating temperature range to maximize data throughput under varying environmental conditions without the need for modem retraining.

Patented



to Electronic Techniques  
(Anglia) Limited

## SPECIFICATIONS

### Electrical

At T = 25°C and as circuit Fig. 2 unless otherwise stated.

Parameter	Conditions	Min	Typ	Max	Units
Insertion Loss	f = 2kHz, R <sub>L</sub> = 600Ω	-	1.5	-	dB
Frequency Response	LF -3dB cutoff	-	10	-	Hz
	HF -3dB cutoff	-	55	-	kHz
	100Hz – 4kHz	-	-	±0.1	dB
Return Loss <sup>(5)</sup>	200Hz – 4kHz	16	-	-	dB
Transhybrid Loss <sup>(5)</sup>	200Hz – 4kHz	20	-	-	dB
Third Harmonic Distortion <sup>(1)</sup>	150Hz -3dBm in line	-	-70	-	dBm
	200Hz -10dBm in line	-	-89	-	dBm
Voltage Isolation <sup>(2)</sup>	50Hz	2.12	-	-	kVrms
	DC	3.0	-	-	kV
Operating Range:	Functional	0	-	+70	°C
	Storage	-40	-	+85	°C

Lumped equivalent circuit parameters as Fig. 1

DC resistance <sup>(3)</sup>	Primary resistance R <sub>DCp</sub>	70	-	87	Ω
	Secondary resistance R <sub>DCs</sub>	95	-	120	Ω
Leakage inductance, ΔL		3	3.9	5	mH
Shunt inductance, L <sub>p</sub> <sup>(4)</sup>	200Hz -43dBm	6	9	-	H
Shunt loss, R <sub>p</sub>	200Hz -43dBm	12	15	-	kΩ

#### Notes:

1. Third harmonic typically exceeds other harmonics by 10dB.
2. Components are 100% tested at 3.25kVDC.
3. Caution: do not pass DC through windings. Telephone line current must be diverted using semiconductor line hold circuit or choke.
4. At signal levels greater than -20dBm, L<sub>p</sub> will increase and R<sub>p</sub> will decrease slightly but the effect is usually favourable to the return loss characteristic.
5. Return loss and transhybrid loss can be improved to 30dB in improved matching circuit. The values shown relate to the simplest configuration, Fig. 2.

#### Equivalent Circuit

Fig. 1

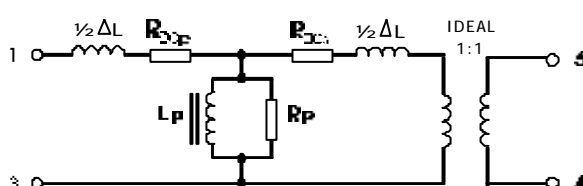

## MATCHING RECOMMENDATIONS

The following recommendations start with the simplest implementations and progress to enhanced performance utilizing additional components. Good performance is achieved even with the simplest configurations. The implementations assume a low impedance balanced TX drive and a relatively high impedance RX input, as is commonly available, though use with other TX/RX arrangements is straightforward. Note that there are no changes to components on the line side, or in the hybrid, whether 600Ω or complex reference impedance selected, thus assisting country configuration. For complex impedance, the matching circuits derived are suitable for reference impedances of the type 270 + 750//150nF e.g. European CTR21 and 220 + 820//120nF (or 115nF) e.g. Australia, South Africa, etc., and yield similar performance characteristics. For other impedances, please contact Profec Technologies.

### Minimum Cost Implementations

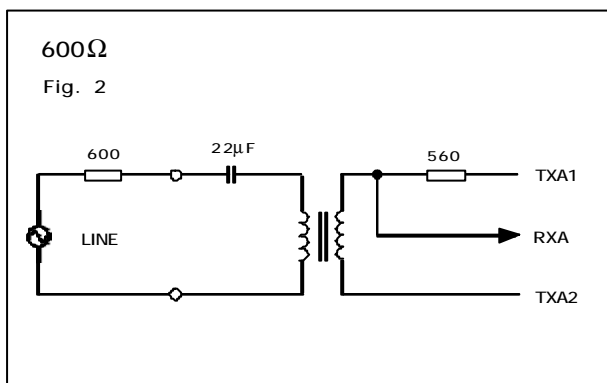

Insertion Loss: 1.8dB @ 2kHz  
 Frequency Response : ±0.2dB 30Hz – 10kHz  
 Return Loss: 16dB 200Hz – 4kHz  
 Transhybrid Loss: 22dB 200Hz – 4kHz

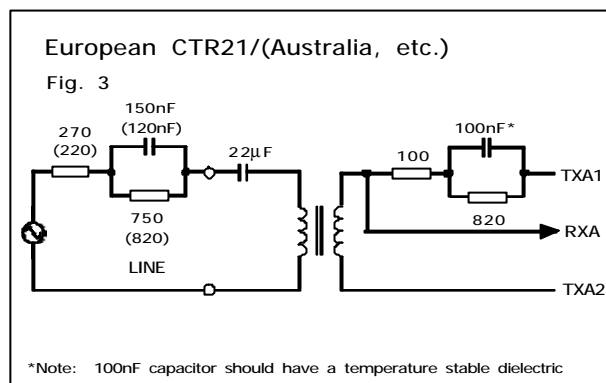

Insertion Loss: 1.0dB @ 2kHz  
 Frequency Response : ±0.5dB 50Hz – 4kHz  
 Return Loss: 18dB 200Hz – 4kHz  
 Transhybrid Loss: 14dB 200Hz – 4kHz

### Improved matching

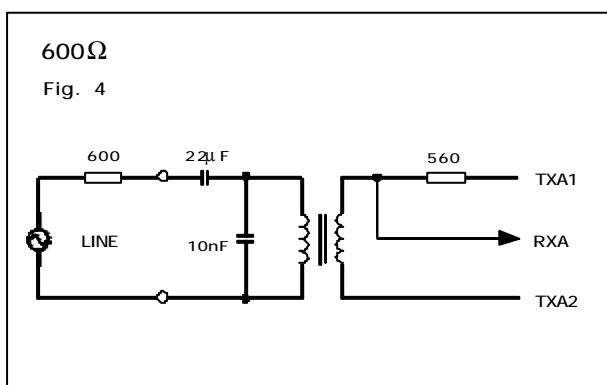

Insertion Loss: 1.8dB @ 2kHz  
 Frequency Response : ±0.2dB 30Hz – 10kHz  
 Return Loss: 18dB 200Hz – 4kHz  
 Transhybrid Loss: 22dB 50Hz – 10kHz

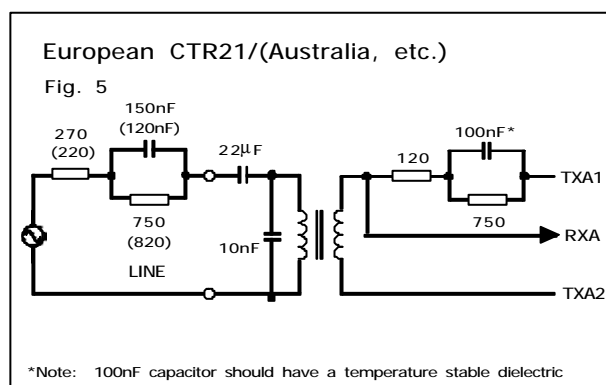

Insertion Loss: 1.0dB @ 2kHz  
 Frequency Response : ±0.5dB 50Hz – 4kHz  
 Return Loss: 20dB 200Hz – 4kHz  
 Transhybrid Loss: 16dB 50Hz – 4kHz

Patented

### Improved matching and hybrid

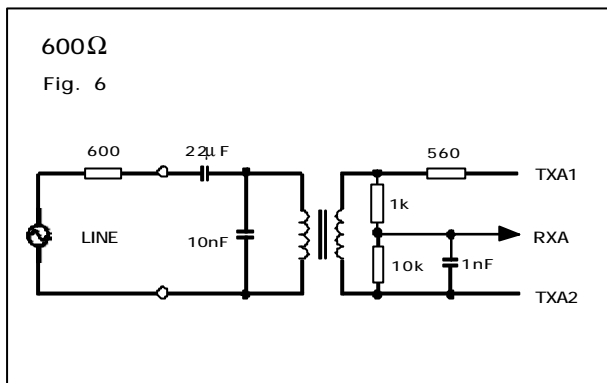

Insertion Loss (Line to RXA): 2.8dB @ 2kHz  
 Frequency Response : ±0.2dB 30Hz – 10kHz  
 Return Loss: 20dB 200Hz – 4kHz  
 Transhybrid Loss: 30dB 50Hz – 10kHz

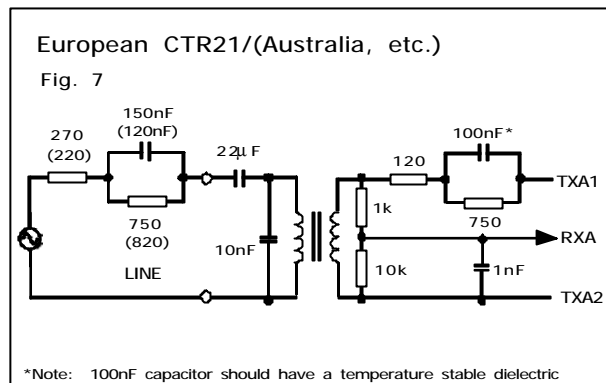

Insertion Loss (Line to RXA): 2.2dB @ 2kHz  
 Frequency Response : ±0.5dB 50Hz – 4kHz  
 Return Loss: 20dB 200Hz – 4kHz  
 Transhybrid Loss: 18dB 200Hz – 4kHz

### 600W Instrumentation

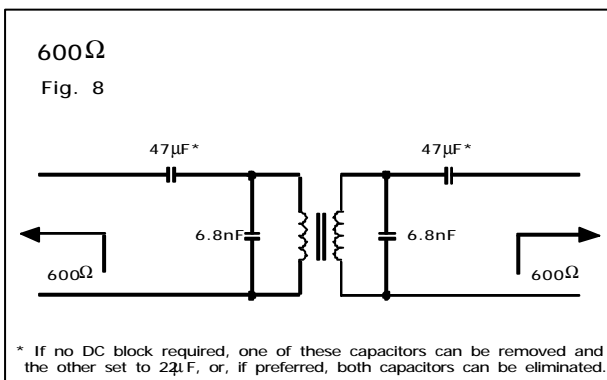

Insertion Loss: 1.5dB @ 2kHz  
 Frequency Response : ±0.2dB 20Hz – 20kHz  
 Return Loss: 16dB 20Hz – 20kHz

### SAFETY

Constructed in accordance with IEC 950:1991, EN 60950:1992 (BS7002:1992) to amendment 5, and UL1950 3rd Edition, supplementary insulation, 250Vrms maximum working voltage, flammability class V-0.

There are no special installation requirements (beyond attending to usual PCB track separations) since the integral cover provides supplementary insulation from its external faces to internal core and windings.

### CERTIFICATION

Certified under the IEC CB scheme (Certificate GB445W) to IEC 950:1991, up to amendment 4, sub-clauses 1.5, 1.5.1, 1.5.3, 2.2, 2.2.3, 2.2.4, 2.9.2, 2.9.3, 2.9.4, 4.4, 4.4.3.2 (class V-0) and 5.3 for a maximum working voltage of 250Vrms, nominal mains supply voltage not exceeding 300Vrms and a maximum operating temperature of 70°C in Pollution Degree 2 environments.

Recognized under the Component Recognition Program of Underwriters Laboratories Inc. to US and Canadian requirements CAN/CSA C22.2 No. 950-95/UL1950, Third Edition, including revisions through to revision date March 1, 1998, based on Fourth Amendment of IEC 950, Second Edition, maximum working voltage 180Vrms (creepage), 420V peak (clearance), Pollution Degree 2, supplementary insulation.

UL File number E203175.

Approved and certified by BAPT to EN 60950 and EN 41003.

BAPT Certificate of Recognition 608755

Additionally, Profec Technologies certifies all transformers as providing voltage isolation of 2.12kVrms, 3kV DC minimum. All shipments are supported by a certificate of conformity to current applicable safety standards.

Patented

## CONSTRUCTION

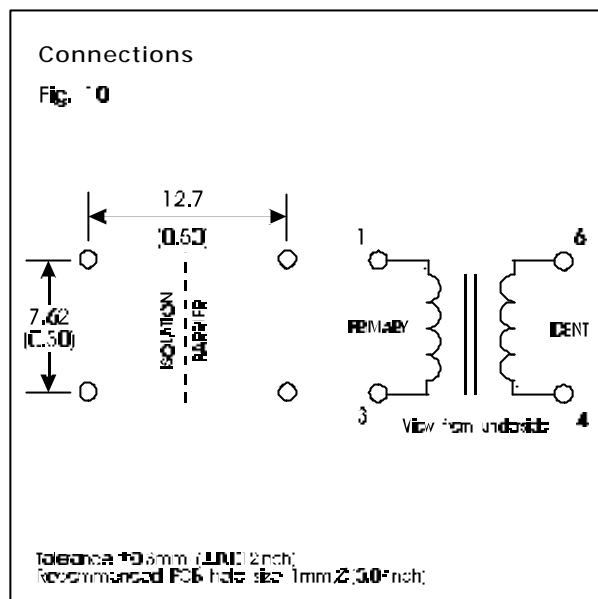
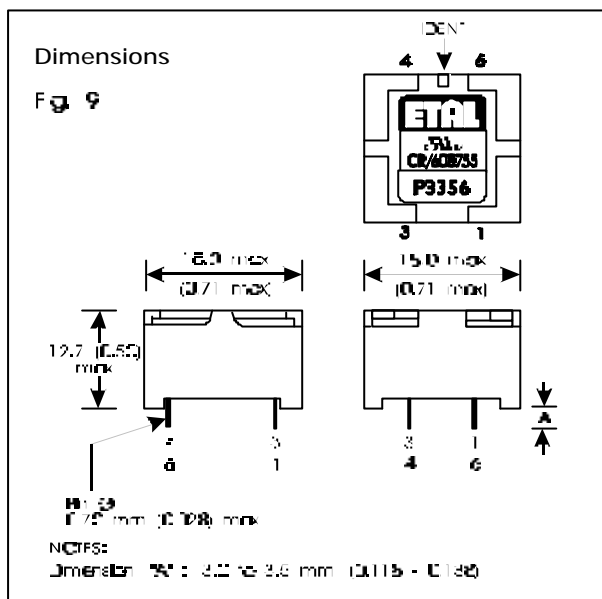

## ABSOLUTE MAXIMUM RATINGS

(Ratings of components independent of circuit).

Short term isolation voltage (1s)	2.12kVrms, 3.0 kVDC
DC current	100µA
Storage temperature	-40°C to +85°C
Lead temperature, 10s	260°C

## COPYRIGHT

ETAL and P3356 are Trade Marks of Profec Technologies Ltd.  
The Trade Mark ETAL is registered at the UK Trade Marks Registry.

Profec Technologies Ltd. is the owner of the design right under the Copyright Designs and Patents Act 1988 and no rights or licences are hereby granted or implied to any third party.

P3356 design and construction are protected by patents and registered design.  
British Patent No. 2333646.  
British Patent No. 2340667.  
UK Registered Design No. 2077360.  
French Registered Design No. 991512.  
Germany Registered Design 49902311.0.  
United States Registered Design 426, 815.  
Other patents and registered designs pending.

© 1998 - 2000 Profec Technologies Ltd.  
Reproduction prohibited.

Patented

**PROFEC**  
TRANSFORMING THE FUTURE



ISO 9001  
FM 25326

Profec Technologies Ltd., 10 Betts Avenue, Martlesham Heath, Ipswich, IP5 3RH, England  
Telephone: +44 (0) 1473 611422 Fax: +44 (0) 1473 611919  
Websites: www.etal.ltd.uk www.profec.com  
Email: info@etal.ltd.uk sales@profec.com